

Mount Maunganui dust monitoring

Prepared by Shane Iremonger, Environmental Scientist



Environment Bay of Plenty
Environmental Publication 2012/04
February 2012

5 Quay Street
P O Box 364
Whakatane
NEW ZEALAND

ISSN: 1175 9372 (Print)
ISSN: 1179 9471 (Online)

*Working with our communities for a better environment
E mahi ngatahi e pai ake ai te taiao*





Mount Maunganui dust monitoring

Environmental Publication 2012/04

February 2012

ISSN 1175 9372 (Print)
ISSN 1179 9471 (Online)

Bay of Plenty Regional Council
5 Quay Street
P O Box 364
Whakatāne 3158
NEW ZEALAND

Prepared by Shane Iremonger

Cover Photo:

Nuisance dust particles collected on the surface of a finger.

Acknowledgements

Dr Bruce Graham for his review of the draft report.

The Pollution Prevention team members (past and present) - Bruce Gardner, David Ede, Mike Caldwell, Adrian Heays and Kelly Baxter for the collection of a variety of intriguing samples.

Helen Turner for the generous use of the Scanning Electron Microscope at Waikato University.

Trig Yates for his cartographic brilliance.

Bernard Simmonds for the timely and accurate work throughout the field monitoring module is acknowledged.

The document specialist skills of Maria Glen/Rachael Musgrave, in the creation of this document.

Executive Summary

The environmental impacts of dust emissions can cause widespread public concern about environmental degradation and/or a decline in amenity. The nature and extent of the problem and significance of the effects usually depend on the nature of the source, sensitivity of the receiving environment and on individual perceptions.

A number of complaints have arisen in the Mount Maunganui and Sulphur Point areas. Complainants raised a number of potential sources but intermittent depositing and a range of physical characteristics exhibited by the collected samples resulted in a situation where accurate source identification was problematic.

In order to gain a better understanding of nuisance dust in the Mount Maunganui area several paths of investigation were undertaken:

- Grab sample collection was undertaken over a period of time by council staff at a range of locations based on complaints and highlighted issues.
- A detailed depositional dust monitoring programme was undertaken in the Mount Maunganui and Sulphur Point areas.
- A continuous particulate (PM₁₀) monitoring instrument was installed at the Council's Totara Street air quality monitoring station.

The key points from these investigations are outlined below.

- Various ambient dust monitoring studies from 2000 to 2010 have shown only two 24-hour results above the recommended nuisance level of 80 µg/m³. Overall, the levels of suspended particulate matter are quite acceptable for an urban area, although moderately higher than levels recorded in other less developed parts of the region.
- More than 30 grab samples have been examined over the last 6 years to assist investigations into dust nuisance effects. Of these four samples provided clear evidence of dust impacts from the coal handling facilities at the Port. However, these samples all preceded the improvements made to the coal handling equipment in mid-2006. Coal dust was identified in two other samples subsequent to that time but it was considered that the port facility was an unlikely source because of the significant separation distances to the complainants' properties.
- Significant amounts of palm kernel dust was identified in six grab samples, since then the handling and storage practices of this material has been modified by the Port of Tauranga.
- Wood and bark material was found in six of the grab samples. Significant amounts were often present in the collected samples. On-going sealing of log storage areas in and around the port and improved yard management will see reductions in material from these potential sources.
- All other grab samples were found to contain various mixtures of typical urban dust particles, including soil and sand, tyre wear, cenospheres and other combustion-related materials, pollens and other plant matter, man-made fibres, paint flakes and particles, rust flakes and possibly welding residues.

- The analysis of the grab samples was supported by a visual impact monitoring programme carried out from August to December 2008. The results from this showed that the greatest dust impacts were shown to occur at sites closest to the main port area at Mount Maunganui. Much of the dust impacts were attributed to the same general materials as noted in the point above. However, a few of the samples collected downwind of specific locations (Sites 4, 5 and 18) showed clear evidence of impacts due to palm kernel and log handling activities.
- Finally, samples of particulate emissions were collected from six industrial sites identified as having the greatest potential for off-site impacts. Some of the particles were found to be quite unique, and would be easily identified in samples of fallout. Other particles also had a unique appearance (eg. cenospheres) but could be produced by a number of different sources. However, there were also particles that would be difficult to distinguish from those commonly found in most urban environments (eg. cement dust, and aggregate dust from asphalt plants).

Overall the results of this report show that the Mount Maunganui and Sulphur Point areas can experience elevated levels of nuisance dust and particular dust events when certain meteorological conditions exist. The heterogeneous particle composition of most of the dust does not point to any one particular industrial operation, but rather to a range of contributing sources. The port operation in the centre of the area of interest undertakes a number of activities which can result in issues offsite if not well managed, as shown in a number of the grab samples and the directional dust detector programme results. Activities such as volumes of heavy traffic supporting the operation of the port, commercial and industrial activities can also contribute to elevated levels of dust. Sweeping frequency and best practice yard management should be regularly reviewed for operations within this area to ensure offsite effects are minimised.

Contents

Acknowledgements	i
Executive Summary	iii
Part 1: Introduction	1
Part 2: General dust information	3
2.1 Dust sources	3
2.2 Dust characteristics	4
2.3 Health effects	5
Part 3: Description of Mount Maunganui area	9
3.1 Population	9
3.2 Land use	10
3.3 Harbour link development	15
3.4 Consented activities and the Regional Air Plan	15
3.5 Other impacts on air quality	18
3.6 Meteorology	18
3.7 Topography	24
3.8 Natural dust sources	24
Part 4: Complaints database summary	31
4.1 Complaints summary	31
Part 5: Historical monitoring information	35
5.1 Historical monitoring	35
Part 6: Grab sample data analysis	45
6.1 Open coast beach and Pilot Bay samples	47

6.2	Tawa and Miro Street, 2006	49
6.3	Mount Maunganui Cosmopolitan Club, Miro Street	55
6.4	Pitau Road, 2007, No.1	56
6.5	Pitau Road, 2007, No. 2	59
6.6	332 Maunganui Road, July 2007	67
6.7	Tawa Street, June 2007	72
6.8	Totara Street, June 2007	76
6.9	Bruce Gardner samples, 2008	80
6.10	May Street, October 2008	94
6.11	Unit 34, 57 Pitau Road (C2009 1077)	95
6.12	Ultimate Motor Group sample	96
6.13	135c Marine Parade	97
6.14	Cutters Cove samples (C2009 0371)	98
6.15	135 Totara Street, Chumneys Lunch Bar (C2009 0348)	99
6.16	24B Miro Street	100
6.17	2/30 Miro Street (C2009 0360)	101
6.18	Kippen Way	102
6.19	Tauranga Marina Society, 4 September 2008	104
6.20	144 Oceanview Road, 12 April 2010	105
6.21	Port of Tauranga - Sulphur Point area samples	107
6.22	Samples collected from a roadway, 2008	109
6.23	Grab sample summary	109
Part 7: Samples from other locations within the Bay of Plenty		111
7.1	Rotorua	111
7.2	Te Puke	112
7.3	Whakatāne	112
7.4	Discussion	113

Part 8: Directional Dust Detector programme	115
8.1 Directional dust detector programme	115
8.2 Samples next to a development site, 2008	129
8.3 Directional dust detector programme summary	130
Part 9: Industrial stack emissions	131
Part 10: Summary and Conclusions	133
10.1 Background information	133
10.2 Meteorological conditions	134
10.3 Other relevant factors	134
10.4 Complaints data	135
10.5 Air monitoring data	135
10.6 Dust complaint investigations	135
10.7 Visual impact monitoring	136
10.8 Conclusions	137
Appendix 1 – Soil parameters and descriptors particle size	141
Appendix 2 – Graham Environmental Limited – Mount Maunganui dust	143
Appendix 3 – Flow chart showing coal discharge from ship to shed then onto train	145
Appendix 4 – Directional Dust Sampler	147
Appendix 5 – Directional Dust Detector Results	157
Appendix 6 – Independent particle assessment	163
Appendix 7 – Industry stack sample analysis	165

Part 1: Introduction

The environmental impacts of dust emissions can cause widespread public concern about environmental degradation and/or a decline in amenity. The nature and extent of the problem and significance of the effects usually depend on the nature of the source, sensitivity of the receiving environment and on individual perceptions. For example, the level of tolerance to dust deposition can vary enormously between individuals. However, individual responses can also be affected by the perceived value of the activity producing the dust. For example, people living in rural areas may have a high level of tolerance for the dust produced by activities such as ploughing or top-dressing, but a much lower tolerance level for dust from unsealed roads¹.

Issues caused by nuisance dust are often identified in the Bay of Plenty region particular in relation with earthwork activities or poor operational practices by individual industries. These are normally resolved by the relevant Council staff and often where applicable or appropriate the implementation or modification of a site dust management plan.

A number of complaints have arisen in the Mount Maunganui and Sulphur Point areas. Complainants raised a number of potential sources but intermittent depositing and a range of physical characteristics exhibited by the collected samples resulted in a situation where accurate source identification was problematic.

In order to gain a better understanding of nuisance dust in the Mount Maunganui area several paths of investigation were undertaken:

- Grab sample collection was undertaken over a period of time by council staff at a range of locales based on complaints and highlighted issues.
- A detailed depositional dust monitoring programme was undertaken in the Mount Maunganui and Sulphur Point areas.
- A continuous particulate (PM₁₀) monitoring instrument was installed at the Council's Totara Street air quality monitoring station.

The results from these pieces of work are combined with an aerial photography assessment, meteorological data interpretation, stereo and scanning electron microscope analysis and an understanding of dust characteristics to build a picture of dust in the Mount Maunganui/Sulphur Point area.

This report summarises the above mentioned data collection and analysis streams and identifies possible dominant sources.

¹ MfE, 2001, *Good practice guide for assessing and managing environmental effects of dust emissions*, Ministry for the Environment, ME40-8, Wellington, New Zealand, p58.

Part 2: General dust information

The Ministry for the Environment produced a Good Practice Guidance document¹ for dust in 2001. Parts of this section have been sourced from this guidance document in order to provide some general background information relevant to the situation at Mount Maunganui.

2.1 Dust sources

Airborne dust can arise from a wide variety of anthropogenic sources, including the following:

- Wind-blown dust from exposed surfaces such as bare land and construction sites^{2,3}.
- Wind-blown dust from stockpiles of dusty materials such as sawdust, coal, fertiliser, sand and other minerals⁴.
- Dust caused by vehicle movements on sealed or unsealed roads.
- Agriculture and forestry activities.
- Some transportation emissions such as shipping^{5,6,7}.
- Road works and road construction.
- Building developments⁸.
- Municipal landfills and other waste handling facilities.
- Dry abrasive blasting.
- Numerous industrial operations, including grain drying and storage, timber mills, stonemasons, mineral processing, cement handling and batching, and fertiliser storage and processing.

A number of these activities are present within the area of interest. Some of these activities require an air discharge consent, however unless the scale is significant most are a permitted activity in relation to the Regional Air Plan⁹.

Permitted activities must comply with the no objectionable dust beyond the boundary requirement.

Large quantities of dust can also be generated from natural sources, such as dry river beds, exposed harbour margins, pollen from plants and volcanic eruptions.

² Muleski, G. E., 2005, Particulate emissions from Construction Activities, J. Air & Waste Manage. Assoc. 55: 772–783.

³ USEPA, 2001, Particulate Emission Measurements from Controlled Construction Activities, EPA/600/R-01/031, 179p.

⁴ Billman, B. & Arya, S., 1985, Windbreak Effectiveness For Storage-pile Fugitive-dust Control Wind Tunnel Study, Department of Marine, Earth and Atmospheric Sciences, North Carolina State University, 108p.

⁵ Fridell, E. et. al., 2008, Primary particles in ship emissions, Atmospheric Environment, Vol42, Issue 6, pg 1160-1168.

⁶ Cooper, D. A., 2003, Exhaust emissions from ships at berth. Atmospheric Environment, 37:3817-3830.

⁷ Janhall, S., 2007, Particle Emissions from Ships, Göteborg Atmospheric Science Centre, Department of Chemistry, Göteborg University, 19p.

⁸ Greater London Authority, 2006, The Control of Dust and Emissions from Construction and Demolition, Best Practice Guidance, 68p.

⁹ Environment Bay of Plenty, 2003, Bay of Plenty Regional Air Plan, updated with amendments and adopted by Council on 31 August 2006, 74p.

Fugitive dust sources are typically ground-level sources. The fraction of emissions that are transported long distances from the source of their emissions can be determined from a combination of factors. These factors include:

- Deposition rates. The rate at which particulate matter is deposited to the surfaces of vegetation, man-made structures, and the ground depends upon the size and density of the particles. Also, the characteristics of the surface play a major role. For example, the rate of deposition in urban areas would be greater than in open fields.
- Vertical mixing. Depending upon atmospheric conditions and transport time, vertical mixing can range from a few metres to thousands of metres. Deposition is more efficient if the particulate matter plume is shallow and at ground level.
- Transport time. Transport time acts to both increase and decrease the rate of loss of dust. Vertical mixing increases with time during which the dust concentration at the ground decreases resulting in less deposition. On the other hand, transport time increases the cumulative time allowing for increasing deposition.

2.2 Dust characteristics

Dust particle size is an important factor in determining the way in which the dust moves through the air. It is also relevant for the possible environmental impacts, especially health effects. Particle sizes are normally measured in microns, and the size range of airborne particles is typically from less than 0.1 microns up to about 500 microns, or half a millimetre. This size distribution is shown in Figure 2.1. A micron is one thousandth of a millimetre and therefore invisible to the naked eye.

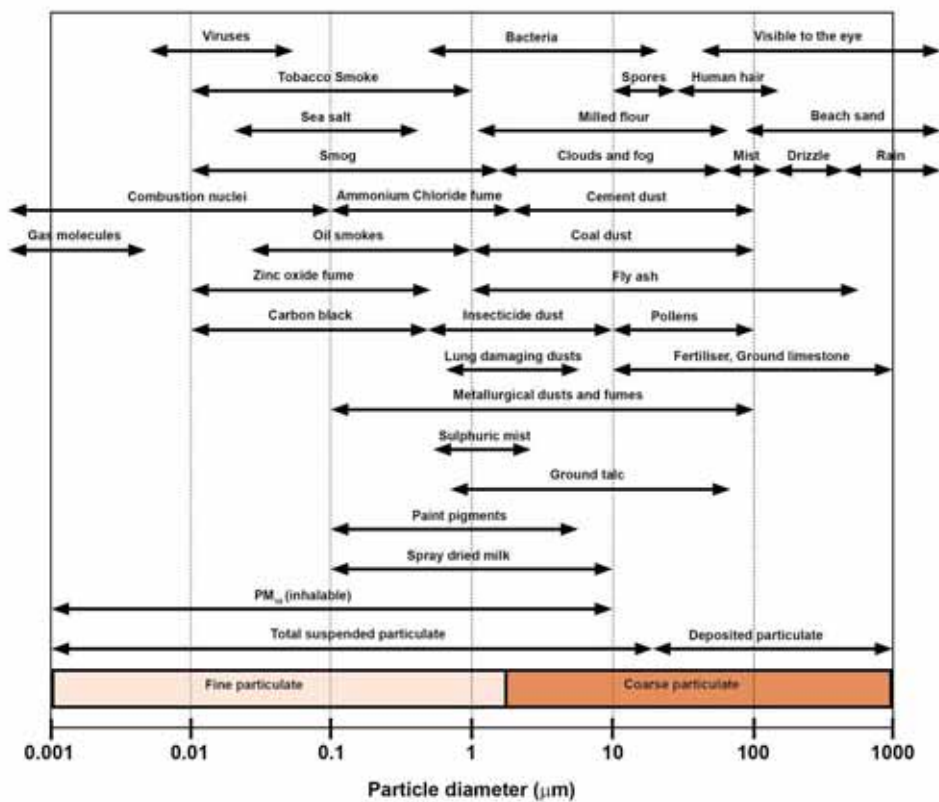

Figure 2.1 Particle size distribution

Particles deposited on a surface will only become individually visible at about 50 microns. For the purposes of comparison, a single sheet of paper is about 100 microns thick, and the diameter of human hair varies from about 30 – 200 microns.

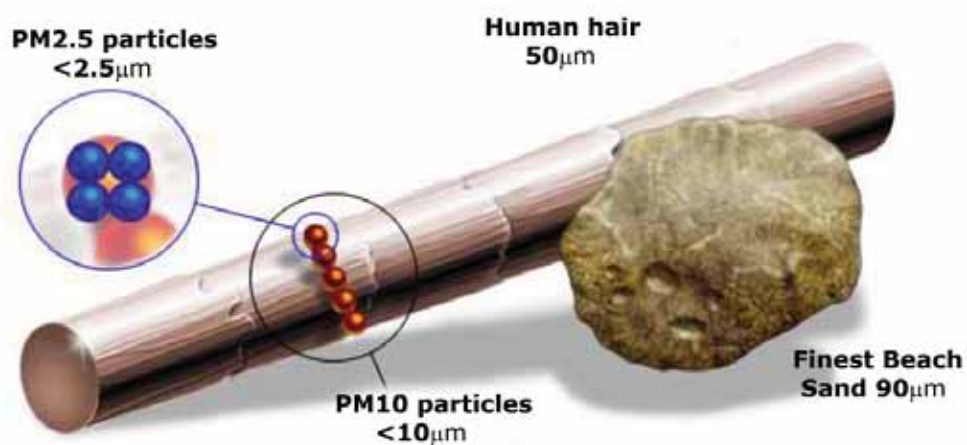

Figure 2.2 Particle size comparison

When dust particles are released into the air they tend to fall back to ground at a rate proportional to their size. This is called the settling velocity. For a particle 10 microns in diameter, the settling velocity is about 0.5 cm/sec, while for a particle 100 microns in diameter it is about 45 cm/sec, in still air¹⁰. To put this into a practical context, consider the generation of a dust cloud at a height of one metre above the ground. Any particles 100 microns in size will take just over two seconds to fall to the ground, while those 10 microns in size will take more than 200 seconds. In a 20 kph wind, the 100-micron particles would only be blown about 10 metres away from the source while the 10-micron particles have the potential to travel about a kilometre. Fine particles can therefore be widely dispersed, while the larger particles simply settle out in the immediate vicinity of the source. Bearing in mind that if suitable conditions prevail (such as strong winds, vehicle activity etc.) then this deposited material can get re-suspended and move in the direction of the prevailing wind to a new location, hence particles can travel much greater distances than given in the simplistic example stated above.

However it is the larger dust particles that are generally responsible for nuisance effects. This is mainly because they are more visible to the naked eye, and therefore more obvious as deposits on clean surfaces. These are also the particles that will settle most readily onto exposed surfaces. For this reason, measurement methods for nuisance dust are generally directed at dust particles of about 20 microns in size and above.

2.3 Health effects

The potential health effects of dust are closely related to particle size. Human health effects of airborne dust are mainly associated with particles less than about 10 microns in size (PM₁₀) (Figure 2.2), which are small enough to be inhaled (Figure 2.3). Nuisance effects can be caused by particles of any size, but are most commonly associated with those larger than 20 microns.

¹⁰ Bagnold, R.A., 1971, *The Physics of Blown Sand and Desert Dunes*, Published by Chapman and Hall, 265p.

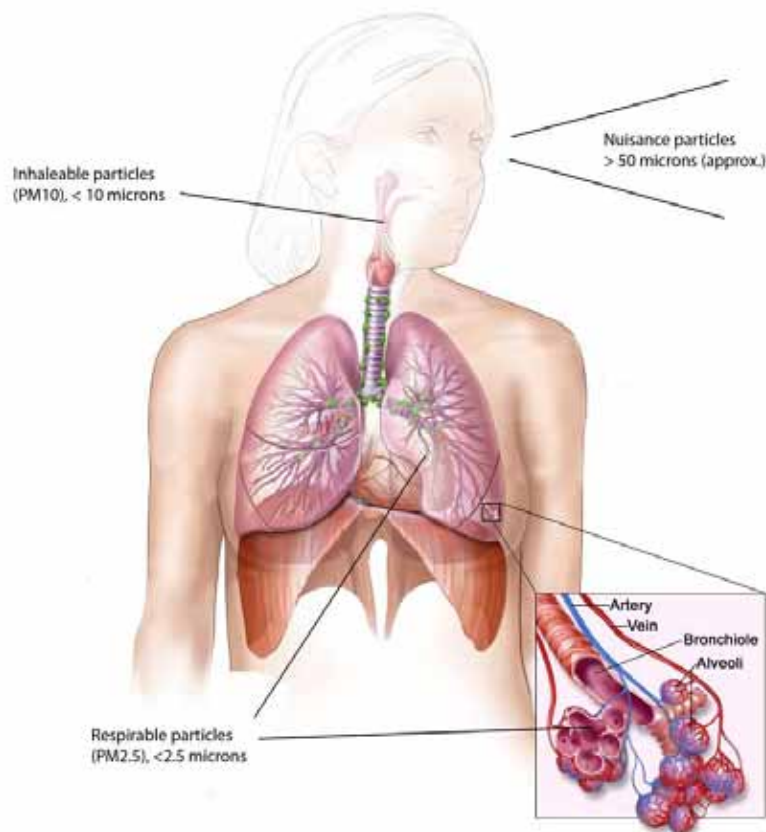

Figure 2.3 Particle effect zones for the human body

Many forms of dust are considered to be biologically inert, and hence the primary effects on people relate to our sense of aesthetics. There can also be minor health effects, such as eye irritation, when the dust is airborne. Indirect stress-related health effects could also arise, especially if dust problems are allowed to persist for an unreasonable length of time.

Some nuisance dust may have the potential to cause other types of health effects because of the presence of specific biologically active materials. For instance, some mineral dusts contain quantities of quartz, which can cause the lung disease known as silicosis when persistent at high concentrations. Other dusts may contain significant amounts of toxic metals such as mercury or lead.

The potential health effects of fine particles (less than 10 microns) are specifically covered under the National Environmental Standards for Air Quality¹¹ (Table 2.1).

¹¹ Resource Management (National Environmental Standards for Air Quality) Regulations 2004 SR 2004/309 (amendments 13 January 2005 - SR2004/433, 25 August 2005 - SR2005 214, 6 November 2008 – SR2008/375, 1 June 2011 – SR2011/103).

Table 2.1 National Environmental Standards for ambient air.

Pollutant	Standard	Time average	Allowable exceedances per year
Fine particles (PM ₁₀)	50µg/m ³	24-hours	1*
Carbon monoxide (CO)	10mg/m ³	8-hours (running mean)	1
Nitrogen dioxide (NO ₂)	200µg/m ³	1-hour	9
Ozone (O ₃)	150µg/m ³	1-hour	0
Sulphur dioxide (SO ₂)	350µg/m ³	1-hour	9
	570µg/m ³	1-hour	0

* See discussion on split targets later in this section.

In October 2004, the Government introduced the national environmental standards for air quality. These air quality standards were issued as Regulations in accordance with sections 43 and 44 of the RMA.

They included:

- seven standards banning activities that discharge significant quantities of dioxins and other toxics into the air,
- five ambient air quality standards for carbon monoxide (CO), particulate matter less than 10 micrometres in diameter (PM₁₀), nitrogen dioxide (NO₂), sulphur dioxide (SO₂) and ozone (O₃),
- a design standard for new woodburners installed in urban areas, and
- a requirement for landfills over 1 million tonnes of refuse to collect greenhouse gas emissions.

The ambient standards are a subset of the ambient air quality guidelines which set the minimum requirements that outdoor air quality should meet for a range of air pollutants in order to protect human health and the environment¹². Most of the guideline values adopted in New Zealand have been taken from guidance provided by overseas organisations such as the World Health Organisation¹³.

The Regulations were subsequently amended in December 2004 (SR 2004/433), July 2005 (SR 2005/214) and November 2008 (SR 2008/375). These amendments were largely made for technical reasons.

In 2004, when the air quality standards were put in place, it was expected that all airsheds would comply with the PM₁₀ standard by 2013. However, by late 2009, the Ministry estimated that there would be 15 airsheds which would not comply in time, including Auckland, which represents nearly 30% of New Zealand's population. There was concern that the 2013 deadline was unachievable.

¹² Ministry for the Environment. 2002. *Ambient Air Quality Guidelines*, Report ME437 prepared by the Ministry for the Environment and the Ministry of Health. Wellington: Ministry for the Environment. Available from www.mfe.govt.nz

¹³ World Health Organisation. 2006. *Air Quality Guidelines Global Update 2005, Particulate matter, ozone, nitrogen dioxide and sulphur dioxide*. Denmark. WHO Regional Office for Europe. Available on www.who.int

In response, the air quality standards were amended in June 2011 with the main changes being:

- Extending the target date for regional councils to meet the ambient PM₁₀ standard. New split target dates are 1 September 2016 (airsheds with between 1 and 10 exceedances of the ambient PM₁₀ standard) and 1 September 2020 (airsheds with 10 or more exceedances of the ambient PM₁₀ standard).
- Making provision for the exclusion of exceptional events (e.g., dust storms, volcanic eruptions).
- Requiring 'offsets' from certain new industries with PM₁₀ discharges in 'polluted' airsheds from September 2012, replacing the current restrictions on industrial consents.
- Prohibiting new solid fuel-burning open fires in homes in polluted airsheds from September 2012.

In addition, the Regulations now allow for a rule, resource consent, or bylaw that is more stringent than these Regulations to prevail over the Regulations.

A key element of this standard is the designation of "airsheds" under sub-clause 14 of the Regulation. These are to be specified by the Minister for the Environment by a notice in the Gazette.

In response to the Ministry for the Environment's request to nominate airsheds, The Bay of Plenty Regional Council has currently designated only one airshed for the Bay of Plenty region, this is the Rotorua Airshed¹⁴. However all other parts of the region fall into a 'default' region-wide airshed, in accordance with clause 14(a) of the Regulations.

¹⁴ New Zealand Gazette, 2005, *Bay of Plenty Regional Airshed Notice*, New Zealand Gazette, No. 141, 25 August 2005.

Part 3: Description of Mount Maunganui area

3.1 Population

Tauranga is New Zealand's ninth largest Local Authority in terms of population. From the 2006 census the population of Tauranga City was 103,635 (Figure 3.1), which is a 14% increase over the 2001 Census population of 90,912. This increase is significantly higher than the nation-wide growth rate of 7.8% over the same period.

The main areas for growth have been in the Papamoa census area units (CAU), which are to the east of the area of interest. Mount Maunganui North which covers the northern extent of the industrial area (plus the residential strip toward Mauao) showed moderate growth (Table 3.1) along with Omanu which covers the main part of the industrial subdivision as well as the residential strip along the coast. Despite the significant boom in the apartment market, Mount Maunganui North shows a relatively small population increase from 2.7% between 1996 to 2001, to 9.8% between 2001 to 2006, compared with 19.0% for the period from 1991 to 1996. This is accounted for by the high number of unoccupied dwellings (30.9%), indicating that much of the recent development in Mount Maunganui North provides seasonal/holiday homes for people who ordinarily live outside the City¹⁵.

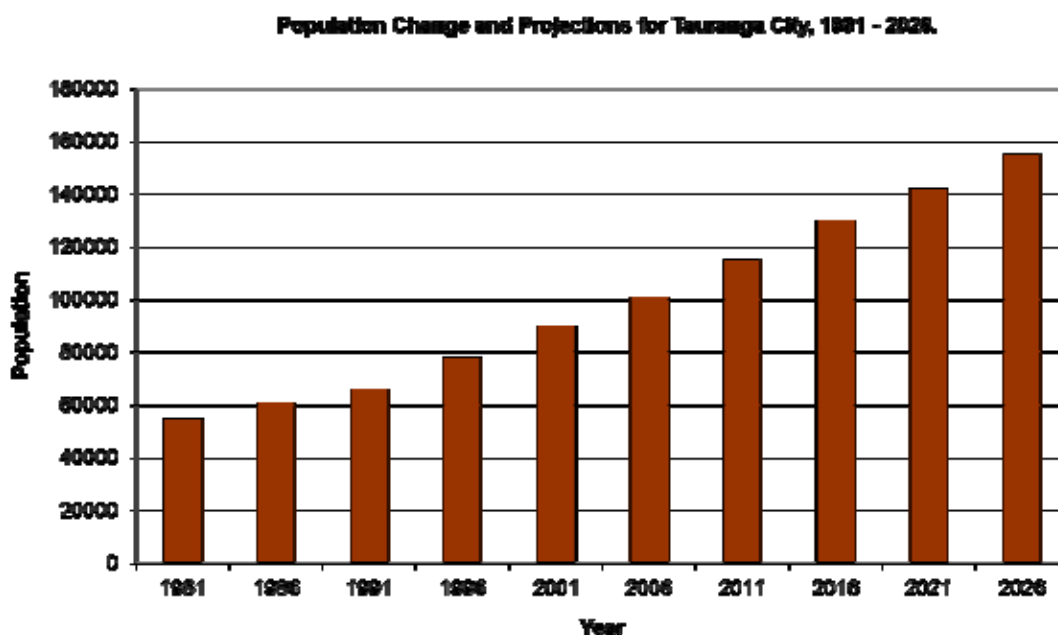

Figure 3.1 Population change and projections for Tauranga City (Source: Statistics New Zealand)

¹⁵ Tauranga City Council, 2008, *Statistical Information Report – Tauranga City*, <http://content.tauranga.govt.nz/reports/stats/StatisticalInformationReport2008.pdf>, 33p

Table 3.1 Tauranga City resident population 1996 – 2006 (Source: Statistics New Zealand)

CAU	1996	2001	2006	% change 96/01	% change 01/06
Mount Maunganui North	3,315	3,402	3,735	2.6%	9.8%
Omanu	4,539	4,815	5,016	6.1%	4.2%
Inlet-Tauranga Harbour	111	18	9	-83.8%	-50.0%
Tauranga City-Marinas	36	69	60	91.7%	-13.0%
Arataki	4,998	5,049	5,127	1.0%	1.5%

3.2 Land use

At present there is approximately 865 hectares of industrial business zoned land within Tauranga City in eight general localities. For the Mount Maunganui area the percentage of vacant land has reduced dramatically from 52% in 1982 to 11% in 2009¹⁶. This transformation is shown (see Figures 3.2) in a collection of aerial imagery taken from the Bay of Plenty Regional Council aerial photography archive.

What also is noticeable from visual observation when moving through the industrial area is the change in land use type. Traditionally the industrial areas have been occupied by predominantly light to medium industrial activities, many of which supported the activities at the Port. However this profile has changed recently and the inclusion of retail outlets within this zone has become popular. An example of such change is the closing of the Carter Holt Harvey (CCH) plywood plant in Hewletts Road which would result in a localised change in air quality.

For Sulphur Point it is noted that the Harbour Link project, which includes the construction of a second harbour bridge and flyovers in this area, has been completed. This project has changed land-use in this area (sand blasting operations associated with the dry dock have now been replaced by the bridge development), and further changes in zoned area and land-use are expected.

¹⁶ TCC, 2009, *Tauranga City Industrial Land Survey 2009*, Tauranga City Council, 20p.

Circa 1900



Circa 1930



Figure 3.2 Land use change at Mount Maunganui.

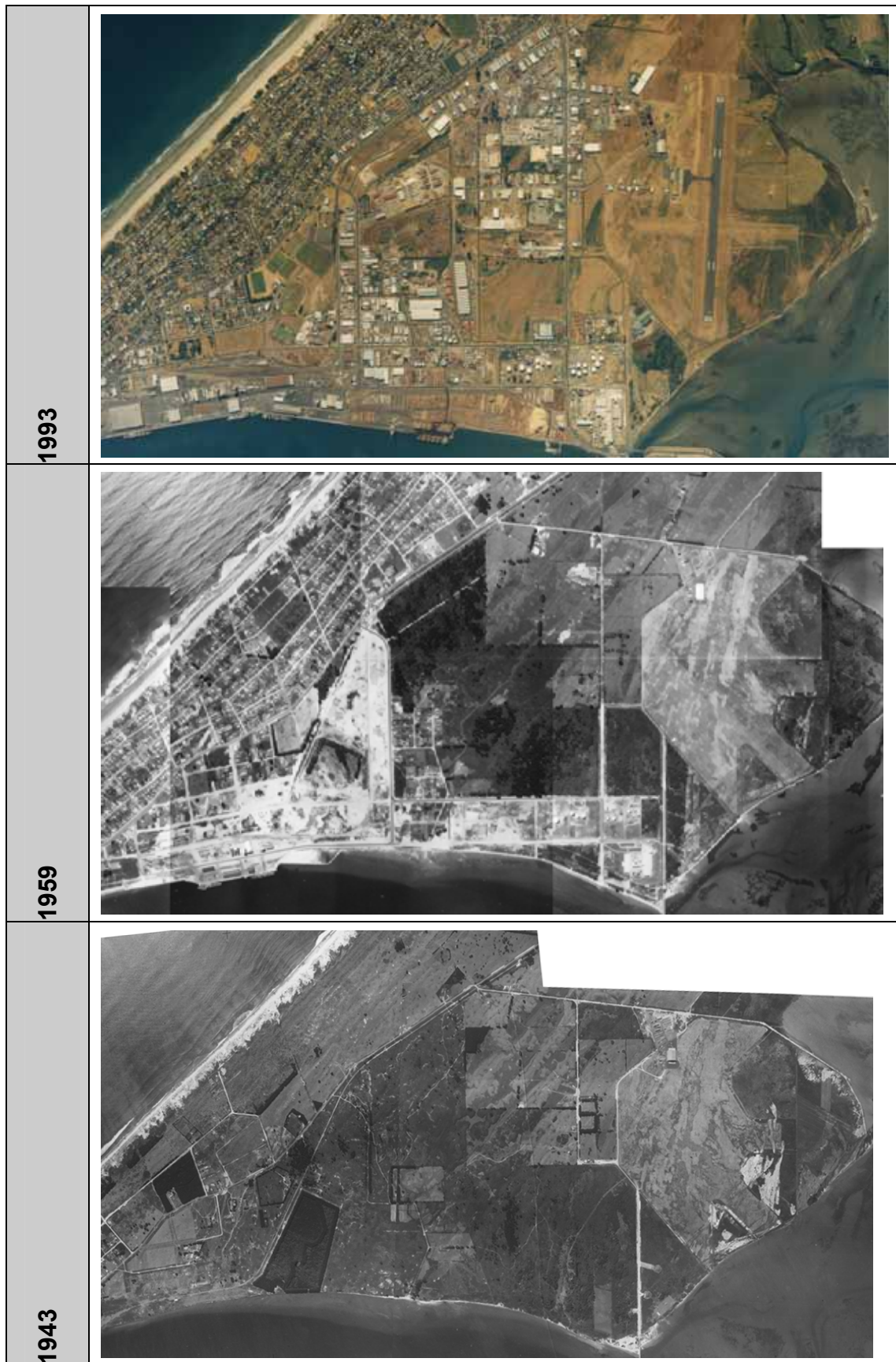

Figure 3.2 contd. Land use change at Mount Maunganui

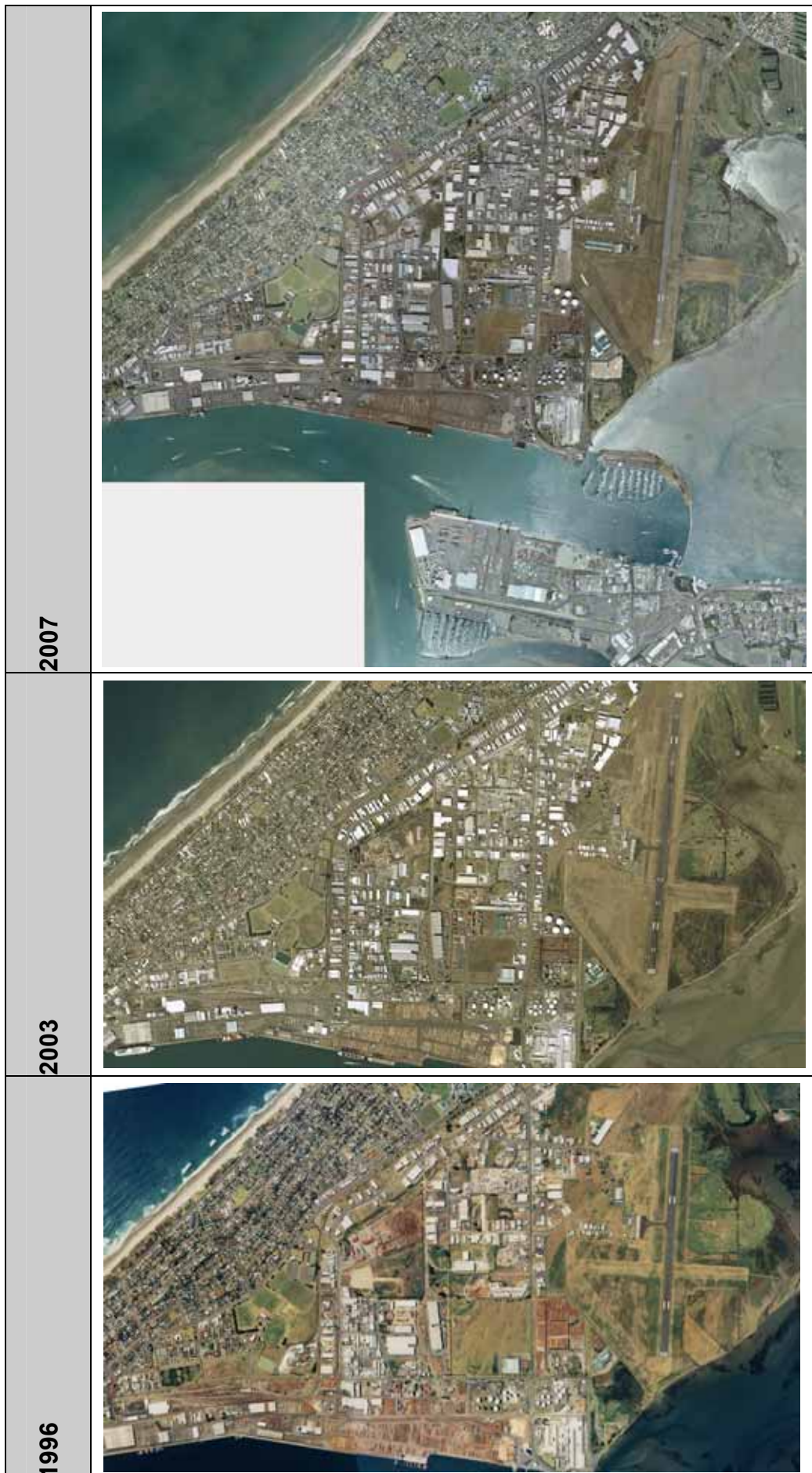

Figure 3.2 contd. Land use change at Mount Maunganui



2007-2010 mosaic

Figure 3.2 contd. Land use change at Mount Maunganui

3.3 Harbour link development

This project provides a duplicate harbour bridge for Tauranga and four lane travel between Tauranga and Mount Maunganui. These additions can be seen in the 2007-2010 aerial mosaic.

Construction of Stage 1 - the four-laning of Hewletts Road from Jean Batten Drive to the old toll plaza on the Harbour Bridge causeway was completed in September 2007. Stage 2 - the new Harbour Bridge and flyover - has been constructed by Fletcher Construction Company Ltd. Physical construction of the bridge project began in August 2007 with pile driving, and the spans touched down on the Mount side in early May 2009. Traffic moved onto the new bridge on 7 September 2009. The new bridge takes traffic from Tauranga to Mount Maunganui and the older bridge takes traffic from the Mount to Tauranga City.

This project had the potential to provide a source of nuisance dust during and post development as material that moved from the sites could be an immediate dust nuisance or be re-suspended to provided extended issues. Determination of this component would be difficult post development as it would have the same characteristics as the existing natural soil contribution.

3.4 Consented activities and the Regional Air Plan

A total of 26 businesses hold air discharge consents in the area of interest (Figure 3.3). Discharge contaminants include both gases and particles. The particle size distribution for these activities will be varied with finer particles typically associated with the combustion related processes. Coarser material will be associated with (but not limited to) panel beating activities although the consents for these businesses are primarily directed at fume emissions from the painting operations. There may also be contributions from other non-consented activities such as vehicle workshops, metal fabrication and finishing, scrap metal processing, joinery factories, bakeries, and wood carving.

For consents where dust generation potential exists there is normally a standard condition which relates to management of this dust in order to ensure there are no adverse effects experienced beyond the boundary.

For consents where dust generation potential exists there is normally a standard condition which relates to management of this dust in order to ensure there are no adverse effects experienced beyond the boundary. An example of such a condition is quoted below from Consent 64800 Ballance Agri-Nutrients Ltd.

“The consent holder shall ensure that all discharges of fertiliser dust and other particulate matter from yards, roads, and storage buildings are controlled so that, in the opinion of the Chief Executive of the Regional Council or delegate, a dust nuisance does not occur beyond the site boundary. Such control of dust shall be in keeping with the Site Environmental Management Plan required by condition 11.2.”

The same general requirement also applies to non-consented (permitted) activities.

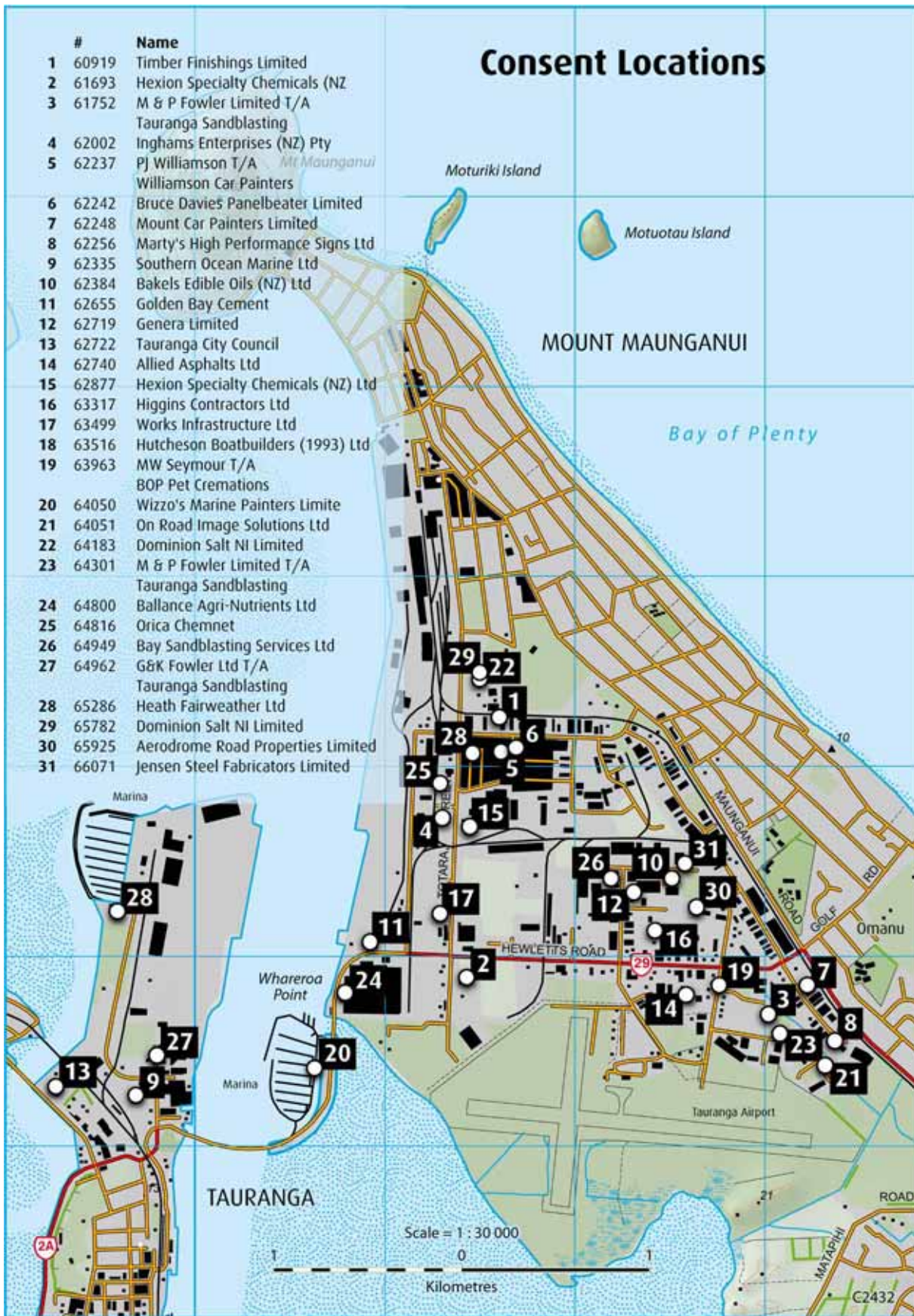

Figure 3.3 Air discharge consent activities as at January 2010

The Regional Air Plan⁹ has an objective of:

Objective 1: Maintain and protect high air quality in the Bay of Plenty region and in instances or areas where air quality is degraded, to enhance it by specifically addressing discharges into air of gases, particulates, chemicals, agrichemicals, combustion and odour.

Section 5.6.5(c) (see Table 3.1) of the Plan discusses particulate matter and how it is to be addressed if there is an issue.

Table 3.1 Regional Air Plan – Particulate Matter

5.6.5(c) Particulate Matter	
	<p>Particulate matter effects relate to the size of particles. Smaller particles stay suspended for longer periods than larger particles. The smaller particles can be inhaled and possibly cause health effects whereas the larger particles tend to fall out close to the source and deposition on surfaces. The techniques for measuring particulate concentrations change for the two particle size groupings. Bay of Plenty Regional Council has chosen to use total suspended particulate as this covers more of the health effects. The nuisance guideline for deposition has an averaging period of a month that does not take account of peak discharges, which are likely to cause offensive and objectionable levels of particulate beyond the source boundary. Deposition measurements may be used at times for assessing peak discharges of deposited material.</p> <p>For particulate matter, the approach will be as follows:</p> <ol style="list-style-type: none">1 A council officer who has experience in particulate complaints will make an assessment of the situation. This assessment will take into account the FIDOL factors which are:<ul style="list-style-type: none">• Frequency of the occurrence;• Intensity of the particulate matter event;• Duration of exposure to the particulate matter;• Offensiveness of the particulate matter; and• Location of the discharge (refer 5.6.5(a)1).2 If the discharge is deemed to be offensive or objectionable by the Council Officer, the discharger will be asked to take whatever action is necessary to avoid, remedy or mitigate the effects of the discharge on the environment.3 If the discharger disputes the Council Officer's assessment or the problem is ongoing, then further evaluation may be required. This evaluation could include:<ul style="list-style-type: none">• An assessment by another Council Officer;• Monitoring of particulate matter beyond the boundary will be compared with the following standard. Discharges into air in excess of the following standards will be considered to be objectionable, offensive or harmful.4 Any particulate matter arising from the activity should not result in levels of suspended particulate matter greater than 350 µg/m³ averaged over 10 minutes or 250 µg/m³ over 1 hour or 150 µg/m³ averaged over 24 hours, at any point beyond the boundary of the subject property. (Derived from the USEPA (United States Environmental Protection Agency) National Ambient Air Quality Standards). <p>If the discharge into air continues to be offensive or objectionable, then enforcement action may be taken. This could be in the form of an infringement notice, abatement notice, enforcement order or prosecution, pursuant to the Resource Management Act 1991. In the case of a permitted activity, failure to comply with the conditions could result in enforcement and would also mean that the activity was no longer permitted and would thus require a resource consent application to be lodged if the person wished to continue with an activity.</p>

3.5 Other impacts on air quality

A range of activities within the area impact on air quality, a detailed emission inventory is currently being collated for the Tauranga area. The last such inventory was completed in 2003 and was for the entire region although some main urban area information was presented. A range of contaminants were assessed, with the finer particulate matter (PM₁₀) data results shown in Table 3.2.

Table 3.2 Quantities of PM₁₀ emissions for a range of locations

Annual PM ₁₀ tonnes per year	Transport					Domestic				Industrial	TOTAL PM ₁₀
	Aviation	Rail	Motor vehicles	Shipping	Total	Backyard burning	Home heating	Lawnmowing	Total		
District											
Taupo	0	0	8	0	8	0.2	0.4	0.0	1	8	16
WBOP	0	5	74	0	79	34	76	0.4	110	354	543
Tauranga	48	2	74	58	182	85	193	1.1	278	46	506
Rotorua	15	0	75	0	89	52	117	0.7	170	567	826
Whakatane	2	6	53	0	61	28	63	0.4	90	145	297
Kawerau	0	0.1	4.2	0	4	6	13	0.1	18	249	271
Opotiki	0	0	17	0	17	8	18	0.1	25	0	43
Total	64	13	305	58	441	211	480	2.8	693	1369	2503
Urban areas											
Tauranga	48	0.502	60	41	149	81	185	1.1	267	30	446
Rotorua	15	0.003	36	0.0	51	44	101	0.6	146	285	482
Whakatane	0	0	8	0.0	8	18	41	0.2	59	2	68

These activities will be discussed in more detail in relation to the dust samples collected for analysis in Section 5

3.6 Meteorology

The wind climate is important when discussing air quality. A summary of a period of record from the Tauranga Aero meteorological site¹⁷ shows the effect of seasonal patterns (Figure 3.4). This will change the natural PM₁₀ composition (such as an increase in sea borne particulate) impacting on the area. A dominant SW quadrant contribution in the annual wind rose will result in material being transported through the industrial area and impacting on the residential zone to the northeast of the industrial area. Winds from the easterly quadrant are less common but can often be gusty as these winds can be associated with depressions positioned to the north and accompanying stronger pressure gradients. Onshore sea breezes are prevalent during the summer months. Calm conditions contribute less than 5% at this site. These wind effects will be discussed in more detail in Section 5.

¹⁷ It should be noted that the council also collects meteorological data at the Totara Street site (<http://old.boprc.govt.nz/MonitoredSites/cgi-bin/hydwebserver.cgi/sites/details?site=248&treecatchment=25>). The Port of Tauranga also has a number of wind monitoring stations (<http://www.port-tauranga.co.nz/Harbour-Conditions>)

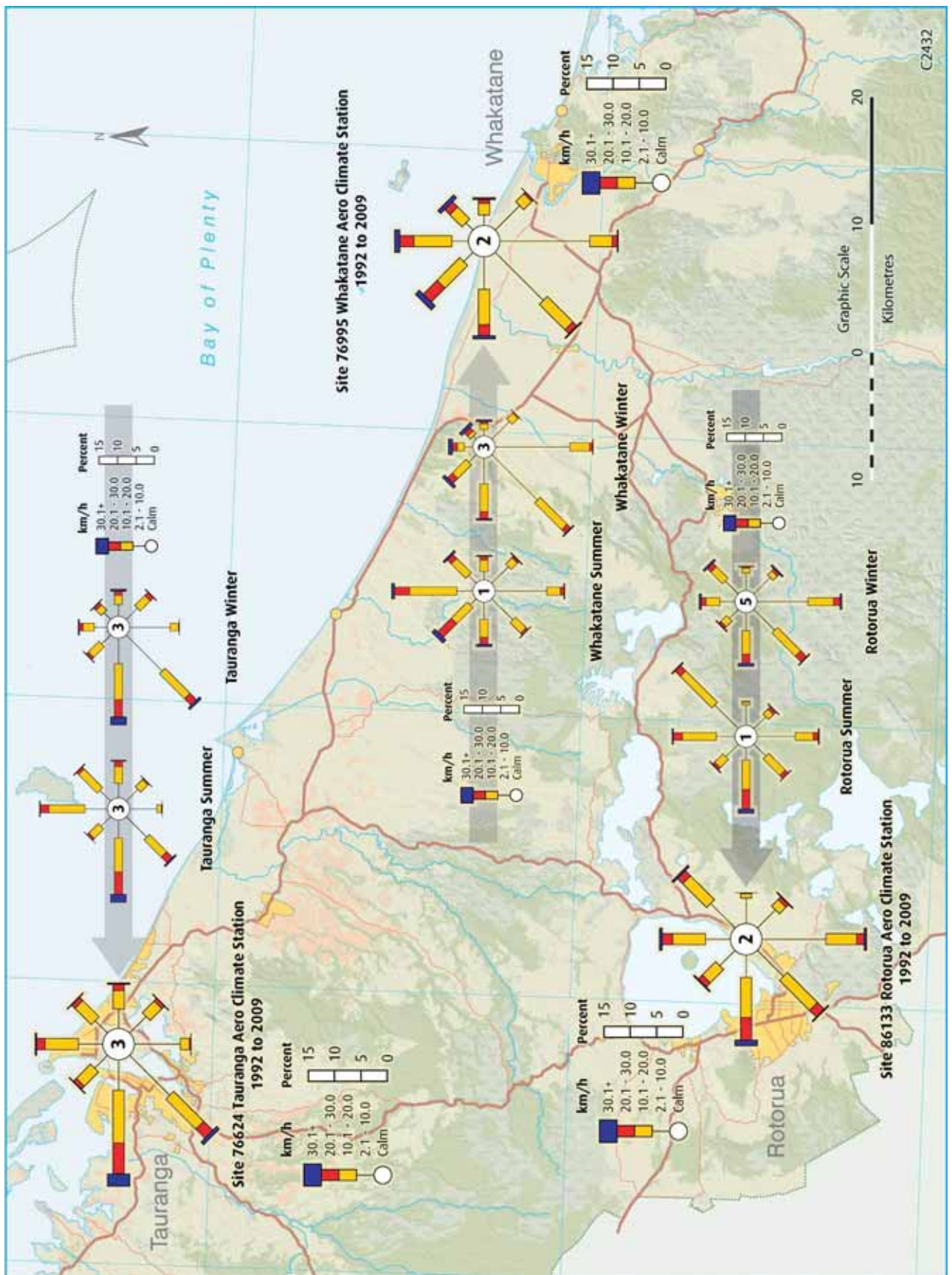

Figure 3.4 Wind patterns for the Bay of Plenty (Data source: <http://cliflo.niwa.co.nz/>)

Diurnal patterns also exist within the wind speed dataset (Figure 3.5). A common pattern exists irrespective of season. Spring and summer sees the elevation of wind speed which builds in strength throughout the day and diminishes during the early evening. This seasonal pattern influences the effect of nuisance dust as during these two seasons rainfall will be less, air temperatures will be elevated and thus dust transport potential is enhanced.

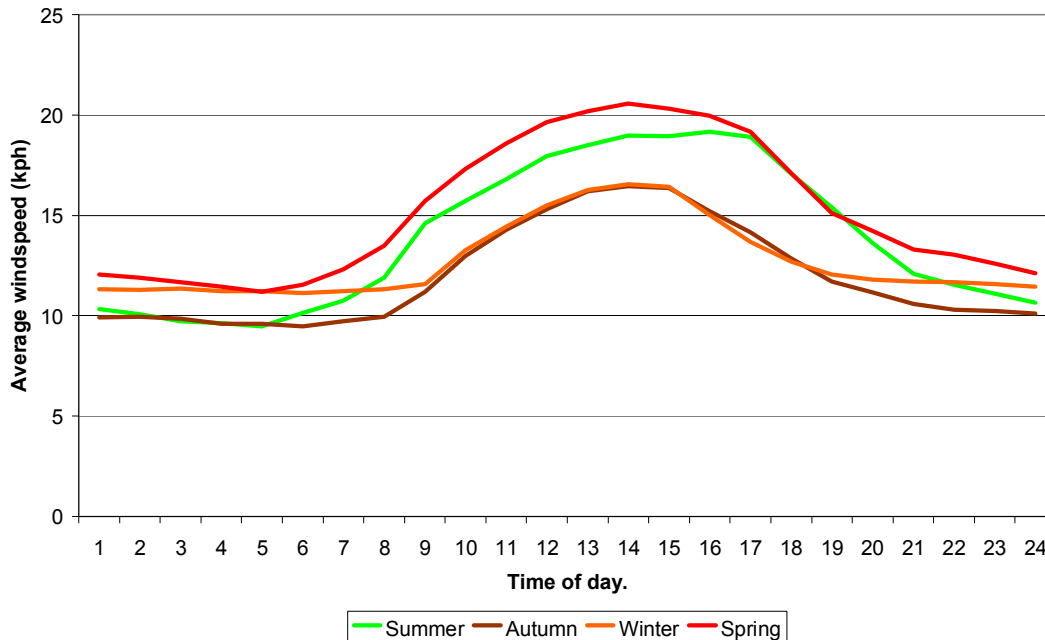

Figure 3.5 Seasonal diurnal wind speed patterns for the Tauranga coastal area

The proximity of the land/sea boundary also affects the local meteorology at this location. Bay of Plenty Regional Council operates a wave buoy which records sea surface temperature at a central Bay of Plenty location, 13 kilometres offshore. A comparison of sea and land temperature (Figure 3.6) shows a marked seasonal pattern and also diurnal variations which drive wind patterns (Figure 3.7) on a finer scale.

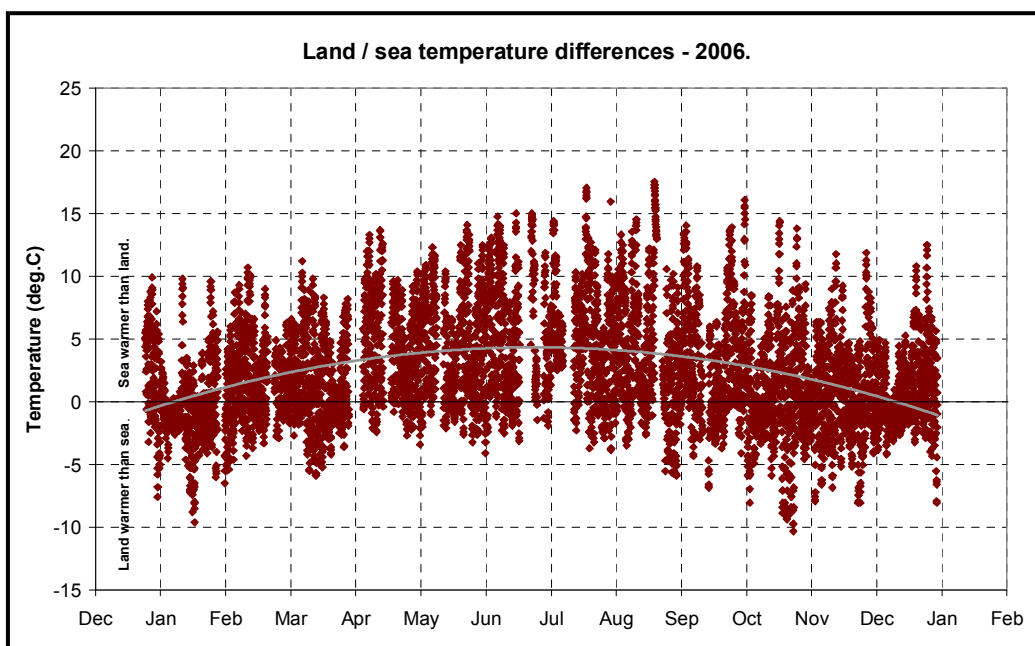

Figure 3.6 Land/sea temperature differences for the Tauranga coastal area

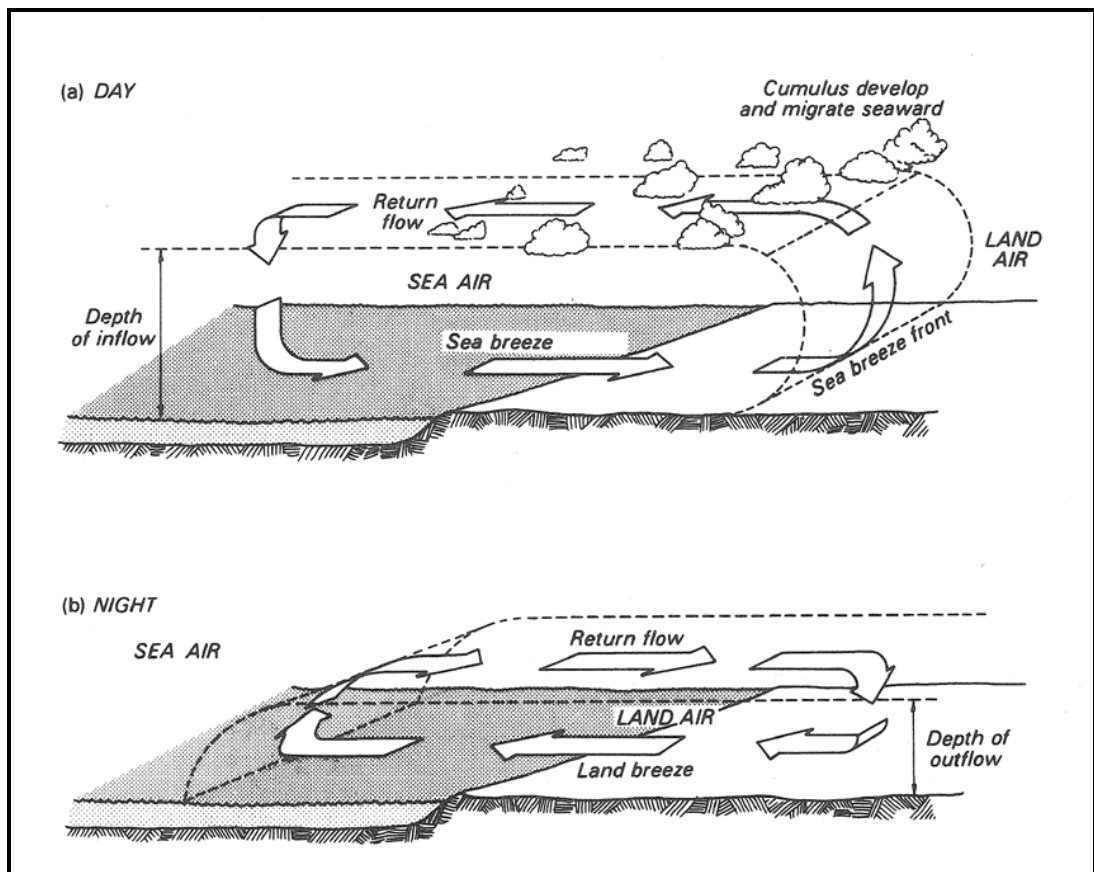

Figure 3.7 Land/sea breeze circulations across a shoreline (a) by day and (b) at night, during anticyclonic weather¹⁸

A typical situation during stable onshore flow conditions is shown in Figure 3.8. In this case a narrow plume imbedded in the stable layer above the shallow marine surface is intercepted by a growing Thermal Internal Boundary Layer (TIBL) over land. The growth of the TIBL is caused by the sensible heat flux associated with solar heating of the land surface. The convection over land can rapidly bring the elevated pollutant to ground, causing locally high ground level concentrations. This situation would only develop from sunrise to ~10 am and would typically have duration of about 1 hour.

¹⁸ Oke, T. R., 1987, *Boundary Layer Climates*, 2nd Edition, Routledge Press Ltd, 435p.

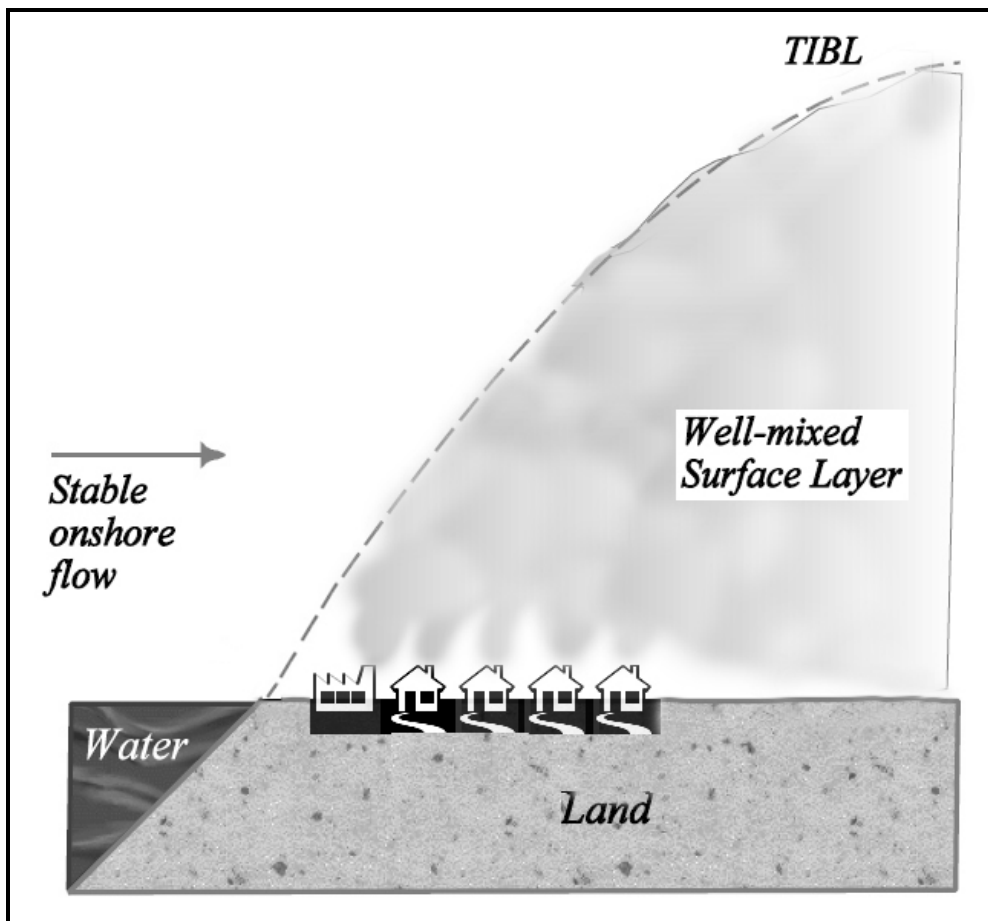

Figure 3.8 Schematic of a typical coastal fumigation situation

Rainfall has the ability to affect air quality, and for the Mount Maunganui area rainfall occurs on average 150 days of the year¹⁹. This precipitation, through the process of wet deposition, scavenges particles when falling rain droplets and these particles collide (washout). Due to the varying scale of this process it is difficult to quantify the effect of localised precipitation on dust particles but it is recognised that it occurs. Evidence of this is shown with a PM₁₀ dataset collected at the Ngāpuna Industrial area in Rotorua (Figure 3.9).

¹⁹ Ellery, G., 2007, *Environmental Data Summaries – Air Quality, Meteorology, Rainfall, Hydrology and Water Temperature*, Report to December 2005, Environment Bay of Plenty, 521p.

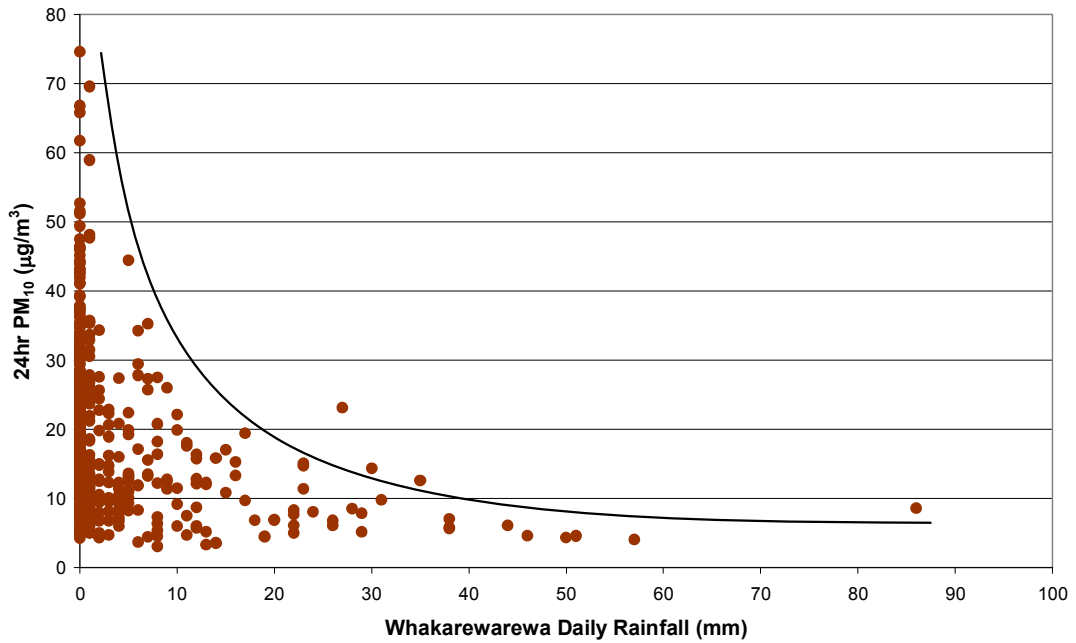

Figure 3.9 Ngāpuna rainfall/ PM_{10} relationship, August 2007 to November 2008, (note rainfall measured on previous day)

There is also a strong seasonal pattern (Figure 3.10), which combined with the wind effect causes times of the year where nuisance dust potential is amplified.

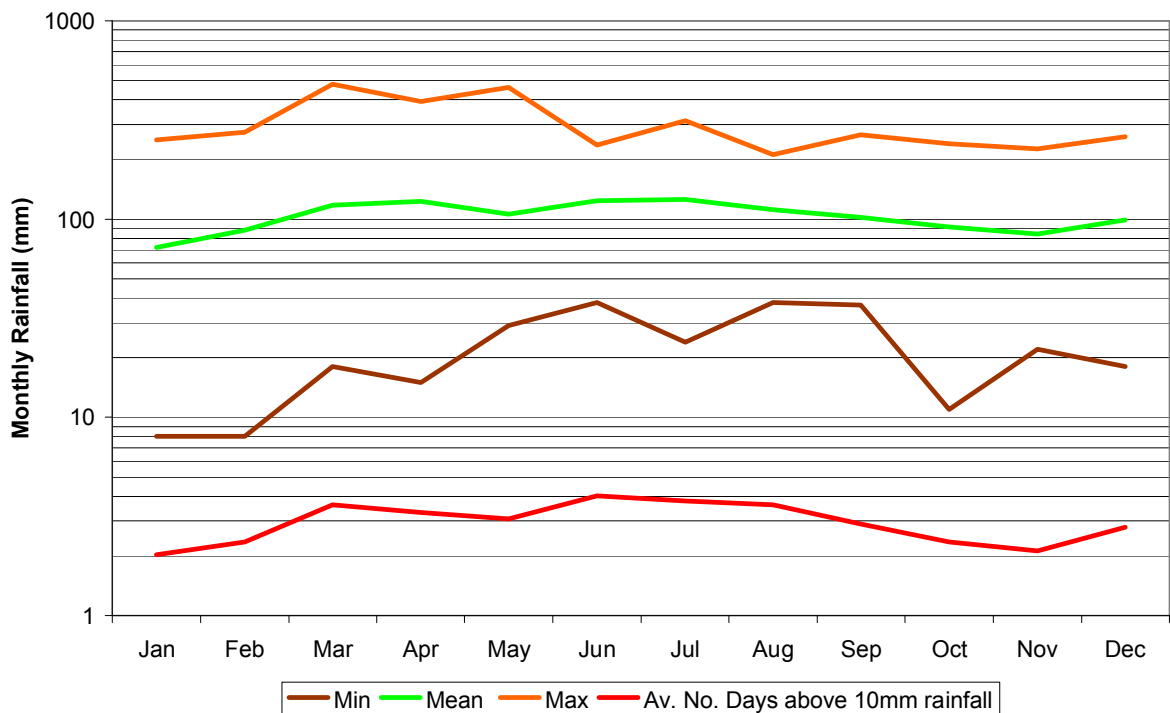

Figure 3.10 Monthly rainfall patterns recorded at the Tauranga Sewage Treatment Plant, Site No. 766101 (NZMS260 U14: 892 872)

3.7 Topography

Across the Mount Maunganui residential and industrial area the elevations are typically low and homogeneous (with the exclusion of Mount Maunganui (231 m) and Mount Drury (32 m)). Heights range from sea level through to ~8 m. Across the Harbour within the city the ground level elevations are more variable (~0 to 70 m) and on the larger spatial scale the layout can provide funnelling of wind derived from the southerly quarter. The Kaimai ranges in the distance (some 20 km away) provide a significant wind boundary from the Waikato region and under suitable meteorological condition will generate katabatic winds. Generally though the Mount industrial area is well exposed to wind from all quarters (Figure 3.4).

3.8 Natural dust sources

Three types of soil are present in the industrial area, (i) Anthropogenic soils (man-made (Mm) are present throughout, (ii) Oe (Ōhope Series) is present along with Mm in a zone north of a line extending from the Ballance Agri-Nutrients Ltd fertiliser works to Portside Drive, (iii) Ki (Kairua Series) is found along with Mm in the zone south of this line, back towards Te Ngaio Papapa Point²⁰. All three soils are well drained and are of an aeolian sand parent material origin. Physical characteristics of these soils make them highly susceptible to wind erosion once any vegetative cover is removed. No detailed mineralogical information exists for these but this can be gleaned from their soil parent materials as follows:

- Oe = Ōhope sand = wind-blown coastal sand derived from rhyolitic rocks,
- Ki = Kairua loamy sand (Podzol) = wind-blown coastal sand derived from rhyolitic rocks with a very thin cover of Kaharoa ash and Taupō pumice,
- Mm = man-made (Anthropogenic soil) = difficult to tell because of soil mixing that has occurred but soil parent materials would most likely be from volcanic ash or similar to Ōhope and Kairua soils.

As shown in the latest imagery in Figure 3.2, extensive areas are already covered by development, however when site development occurs nuisance dust can be an issue for nearby properties for normally only short periods of time.

When discussing wind transported natural material, two large zones are important within the area of interest. These are the open coast beaches and the intertidal zones with the Tauranga Harbour. Both will provide material (Appendix 1) available for wind re-suspension and thus potential contributors to nuisance dust. Particle size analysis undertaken for several research theses^{21,22} show that the intertidal area and coastal margin have sediments of the sizes ranging from medium to fine sands, 500 to 125 µm respectively (Figure 3.13), typically these size of particles will not be transported large distances but frequent re-suspension and further abrasion will result in material of this type travelling significant distances. Initial movement from the active beach environment has been witnessed during strong onshore winds (Figure 3.11).

²⁰ Rijkse, W.C. & Cotching W.E. 1995: *Soils of Part Tauranga County, North Island, New Zealand*.

²¹ Braddock, H., 2006, *Potential Suitability of Maintenance Dredged Sediments for Beach Renourishment at Pilot Bay*, MSc thesis, University of Waikato. p72.

²² Spiers, K., 2005, *Continued Beach Renourishment from Dredged Spoil Disposal*, MSc thesis, University of Waikato, p229.

The mineralogy of these coastal sediments is also a key indicator for nuisance dust analysis, due to the geological development of this and surrounding areas a unique suite of mineral are present in these sediments. These characteristics aid in analysis of dust samples collected from complainants locations. These characteristics are discussed in more detail in Section 6.1.

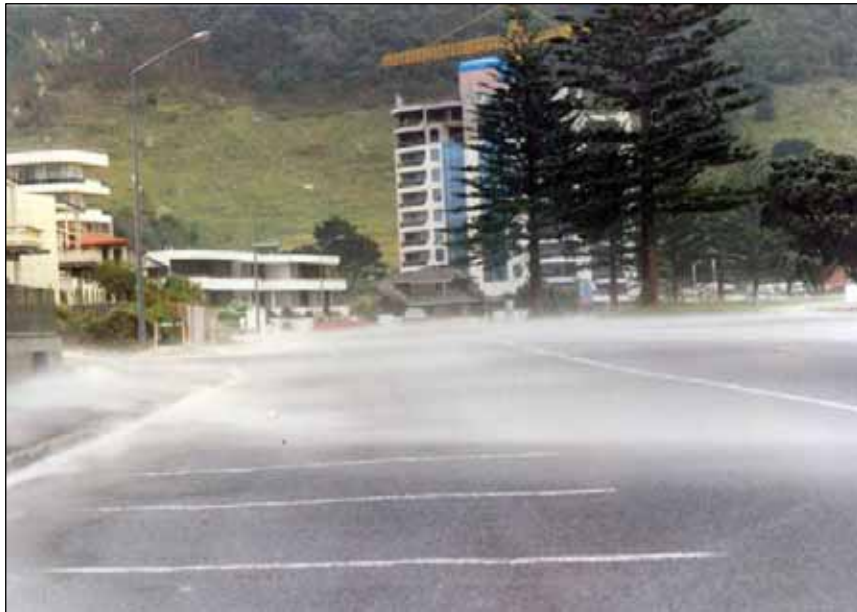

Figure 3.11 Onshore winds transporting sand across Marine Parade, June 1996.

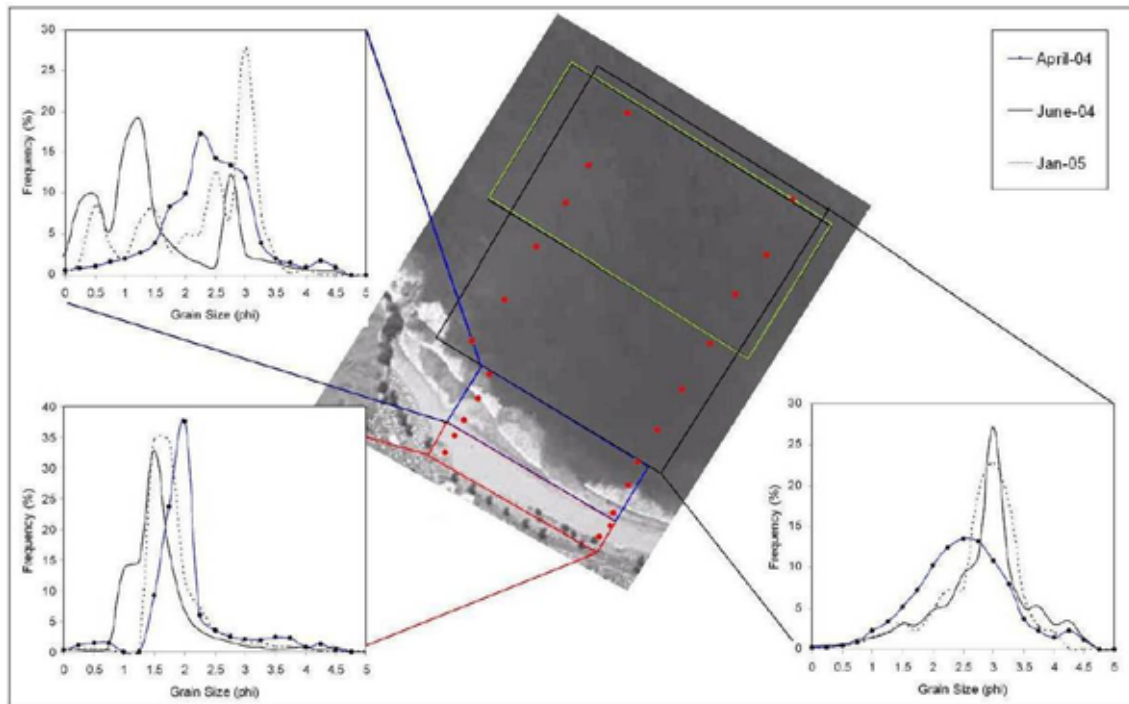

Figure 3.12 Particle size analysis results from Mount Maunganui main beach²²

Seaborne particulate matter (sea spray or salt spray) is a significant source potential nuisance dust. This pattern is exhibited in the seasonal concentration rose from the Otumoetai air monitoring site (Figure 3.13) where an increase in concentration with northerly sea breeze patterns is evident in the summer rose. The same pattern is also present at the other coastal monitoring location at Quay Street, Whakatāne (Figure 3.14) where there is a general increase in the average particulate concentrations when winds are from the north for an extended period of time.

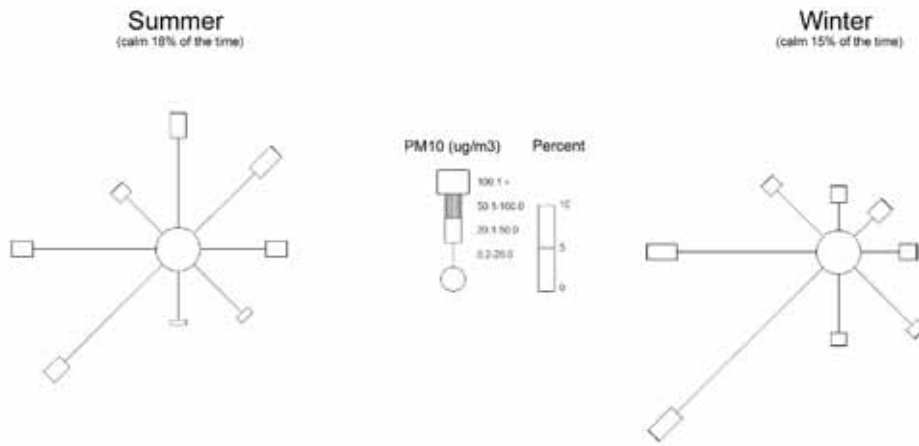

Figure 3.13 Seasonal particulate concentration (PM_{10}) for the Otumoetai monitoring site (1998-2007)

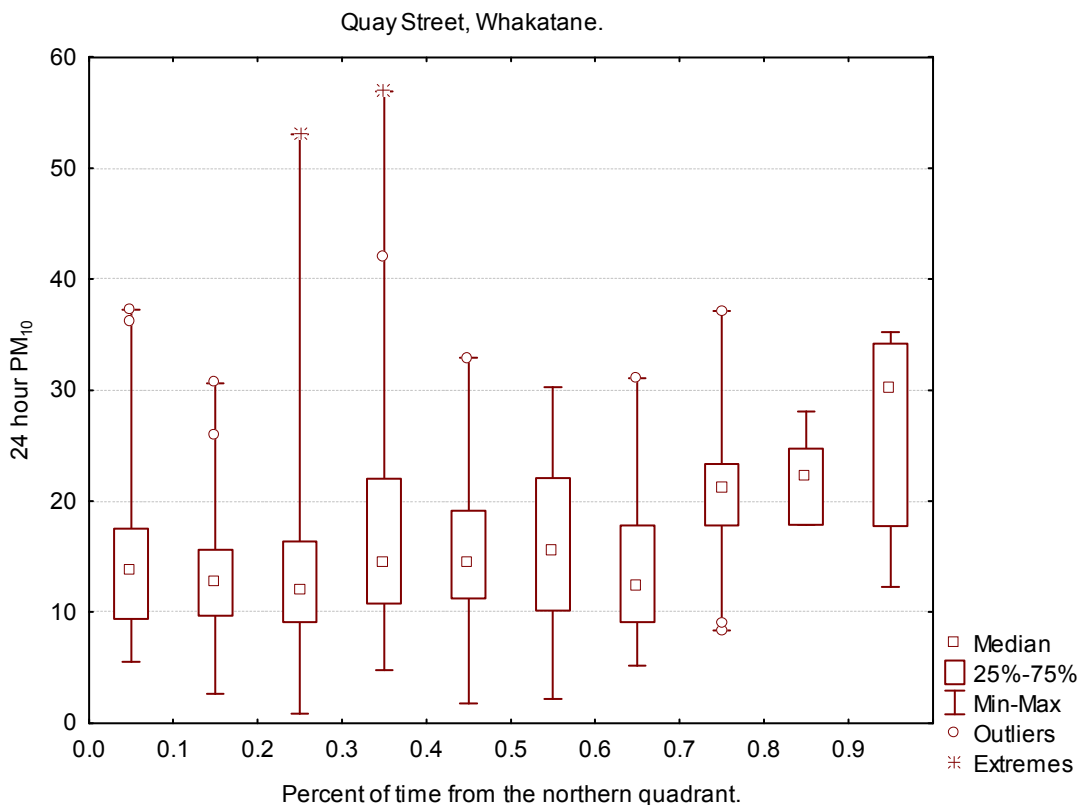

Figure 3.14 Northern quadrant (winds from the north) particulate concentrations (PM_{10}) for the Quay Street, Whakatāne monitoring site (1997-2006)

Recent dust storms in Australia have also brought the nuisance dust issue to the forefront. The dust from this event was monitored in New Zealand with particulate gauges in the upper North Island all recording elevated results for a short period of time (several hours) as the north westerly air stream transported the material across the Tasman Sea (Figure 3.15). Collyer et. al.²³ states wind transport of dust and other solid particles from Australia to New Zealand is a well-established phenomenon. For example, after an unusually dry winter in Australia 'red rain' was observed falling in New Zealand in 1902. In 1928 a major dust storm produced widespread falls of dust over the South Island and the southern half of the North Island. A further fall occurred in 1929, while red snows were reported over the North and South Island snowfields in 1966.

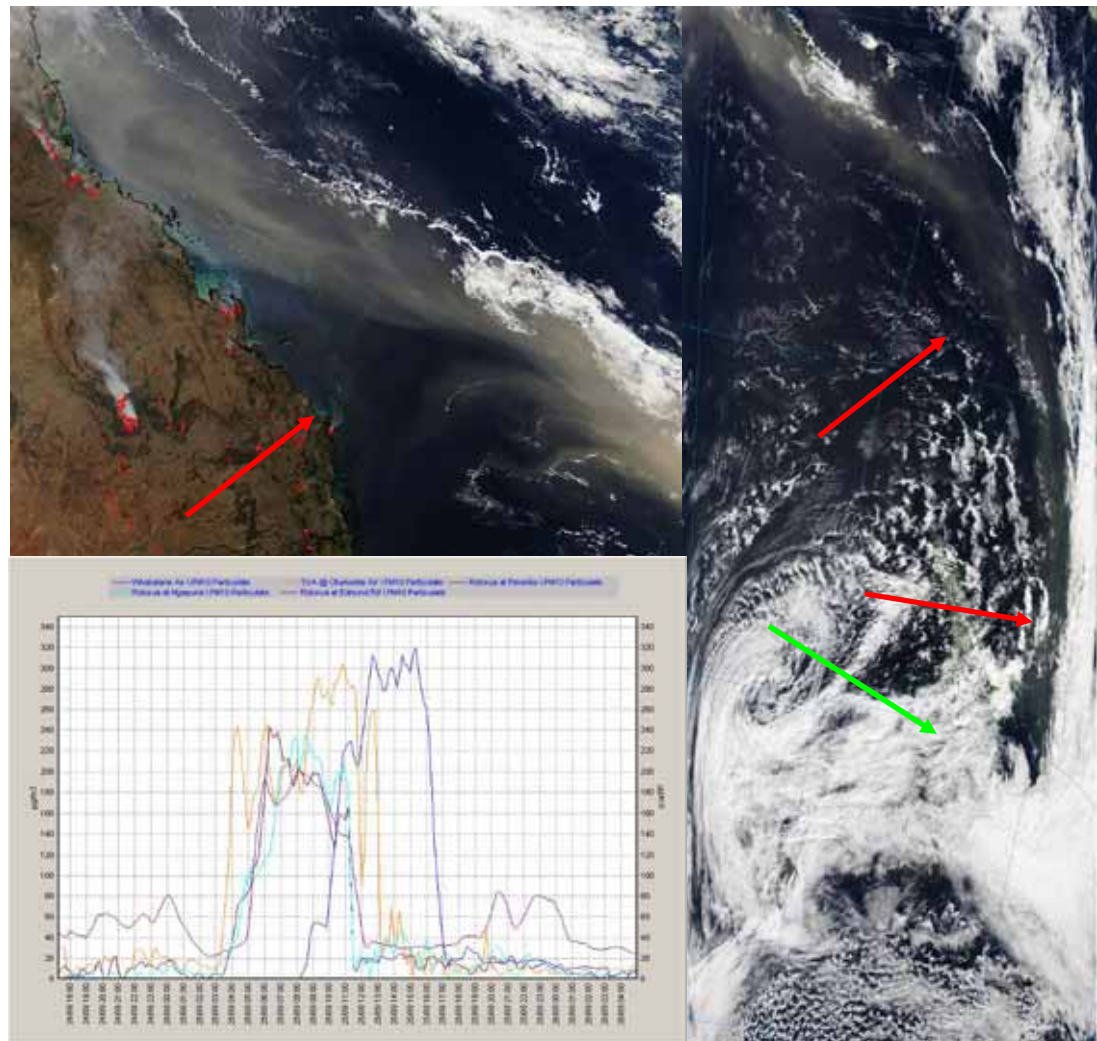

Figure 3.15 Satellite imagery from NASA Modis network showing dust plumes off the eastern Australia coastline (red arrow top left), the same plume 1 day later positioned east of the North Island (green arrow) of New Zealand (right red arrows), and the 10 minute PM_{10} from sites in the Bay of Plenty showing the increase in concentrations as the plume passes across the region.

²³ Collyer, F. X., Barnes, B. G., Churchman, G. J., Clarkson, T. S. and Steiner, J. T., 1984, A Trans Tasman Dust Transport Event, Weather and Climate, 1984 No. 4, p42-46.

Pollen is often linked with air quality issues particularly in relation to the percentage of population that suffers from allergic reactions²⁴. *Pinus radiata* (pine) pollen (e.g. from plantations on Matakana Island) is typically the first to appear each year (~July/August), followed by deciduous trees, including poplars, oaks, elms and hazelnuts, followed by the grass pollen season that normally lasts until Christmas. The pine pollen doesn't penetrate into the respiratory system because the grains are 'large' (Figure 3.16). But they often cause symptoms like a raspy throat and a stuffed nose, symptoms resembling those of a mild cold.

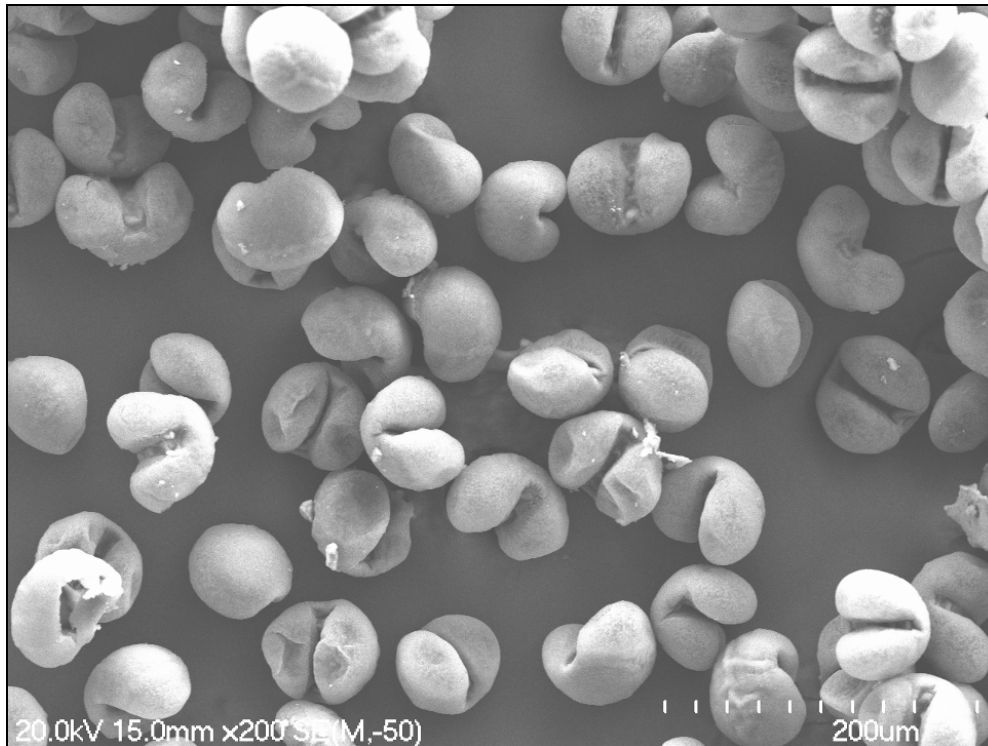

Figure 3.16 Pine pollen sample collected from Mount Maunganui, 2009.

Volcanic eruptions are the final and less common source of material within this category. Fall out material from a White Island eruption has been suspected as the source for material collected at sites in Waihi township²⁵ and the effect of ashfall from eruptions of Mount Ruapehu in 1996 have been well documented²⁶. A model of predicted ashfall plumes from White Island²⁷ is available at the GNS website (Figure 3.17) and regularly shows that if a typical eruption was underway and wind conditions favourable then some of this ejected material would make landfall in Tauranga.

²⁴ Newnham, R. W. et al, 1995, *A National Survey of Airborne Pollen and Grass Flowering in New Zealand, with implication for respiratory disorder*, *Aerobiologia*, 11, p239-252.

²⁵ Graham, B. W., 1999, *Waihi Dust Samples, 30 November 1998, Sampling and Analysis Details*, 2p.

²⁶ Neal, V.E., et al, *Volcanic Hazards at Ruapehu Volcano*,
<http://www.gns.cri.nz/what/earthact/volcanoes/nzvolcanoes/ruabookprint.htm>

²⁷ <http://www.gns.cri.nz/what/earthact/volcanoes/ash/index.html>

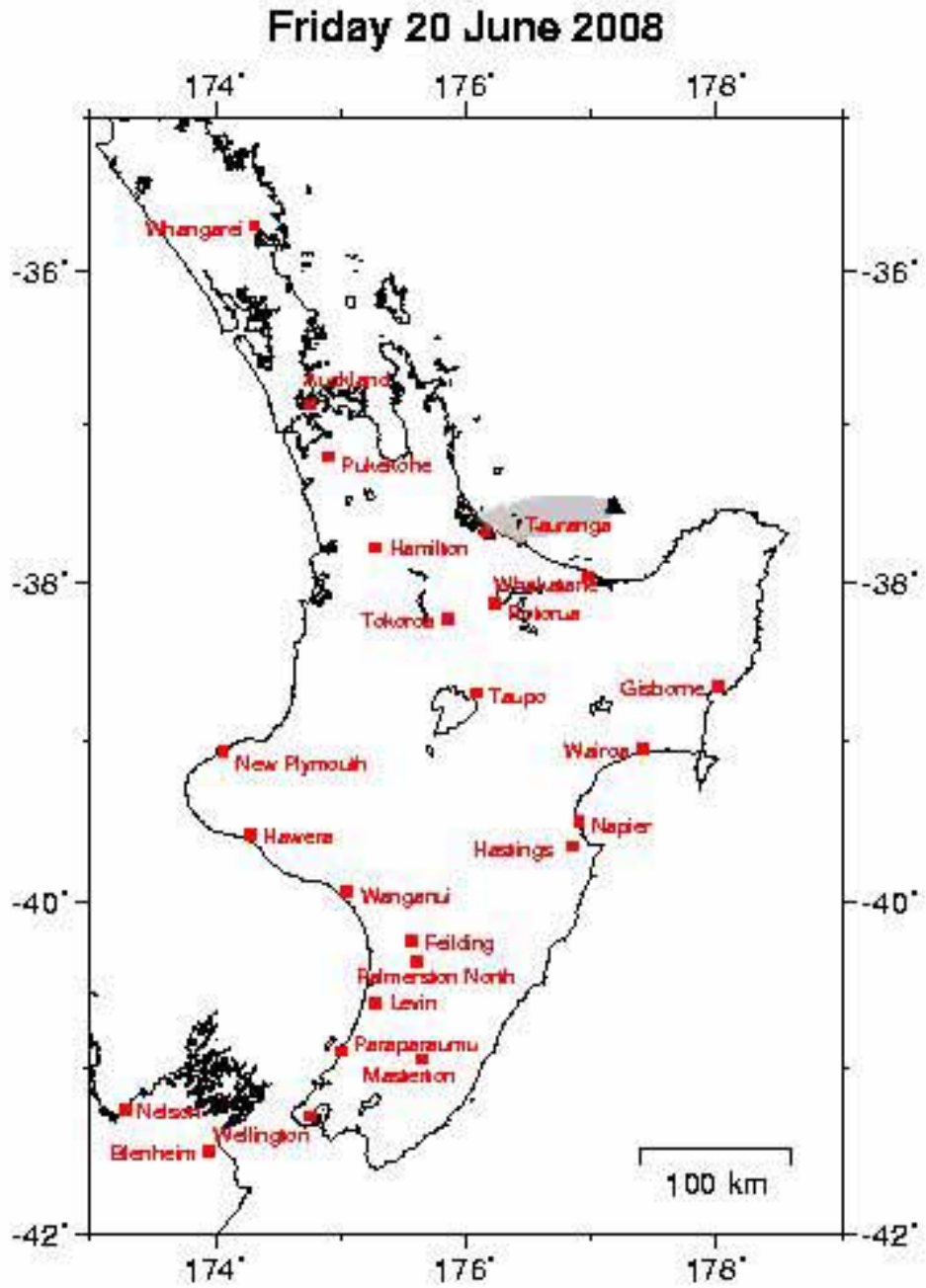

Figure 3.17 Daily modelled output showing ashfall for a typical strength eruption (Source: GNS)

Part 4: Complaints database summary

4.1 Complaints summary

Air quality related complaints in the Bay of Plenty Regional Council Complaint Database²⁸ for the Mount Maunganui area are displayed in the table below based on category.

Year	Category			Total
	Air Dust	Air Odour	Air Smoke	
2000	41	35	20	96
2001	25	26	27	78
2002	24	18	30	72
2003	27	37	26	90
2004	65	67	43	175
2005	43	96	28	167
2006	45	44	33	122
2007	33	46	19	98
2008	38	41	33	112
2009	30	31	20	81
2010	33	36	23	92
2011	16	46	41	103
Total	420	523	343	1286

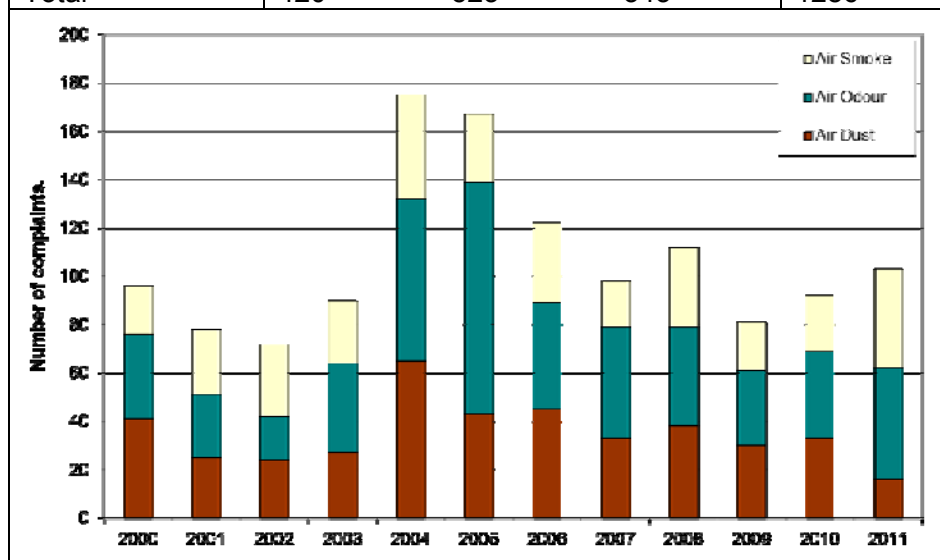

Figure 4.1 Complaint Database summary for air complaints, 2000-2011

An increase in complaints arose during the 2004/2005 period. This coincided with the operational start of the purpose built Port of Tauranga coal transit and storage facility, which receives and stores up to two shipments (70,000 tonnes) of coal, before transshipping to Huntly by rail. Tauranga was the gateway for one million tonnes of coal per annum being imported by Genesis for use in their Huntly PowerStation²⁹. However the demand for this coal has reduced and there has been low activity levels for this part of the port operation since early 2010.

²⁸ Raw data supplied by Steve Pickles & Mellanie Pullar, Pollution Prevention Team, Bay of Plenty Regional Council.

²⁹ Priority One Western Bay Of Plenty Incorporated, 2010, *Port of Tauranga Ltd*, http://www.priorityone.co.nz/western_bay_of_plenty_business_advantages/PortofTaurangaLtd.asp.

The 2004/2005 period was also at a time when there were on-going operational issues at a nearby composting operation. For 2004, 2 of the 65 referred to coal activities, for 2005, 12 of the 43 complaints referred to coal activities.

The storage facility is the only fully-enclosed coal store in Australasia. Dust nuisance from the Tauranga facility is controlled mainly by the fact of containment in a closed structure, with the store itself and all conveyors being fully-enclosed and dust-proofed. At the end of conveyors, the opportunity for dust-creation is limited by fine, chemically-treated water sprays.

Any dust raised by loaders working within the negative-pressure store area is controlled by moisture levels on the floor, with air being filtered before being discharged outside by a large cascade water filter.

Within the rail silos, dust is filtered by fabric Luhr filters. Each of the 30 rail wagons per train is loaded within a 50-metre long concrete tunnel, to control dust and noise. Water, used for washing down and dust-filtering, is collected in settling ponds or chambers and is either recycled or discharged into the sewerage system as trade waste³⁰.

A seasonal pattern (Figure 4.2) for the 2000 – 2011 period is also evident in the dust complaint (and total) records. Drier and windier conditions (summer period) would generally give rise to more dust complaints as this material is distributed more widely throughout the area and re-suspension of deposited material results in extended issues.

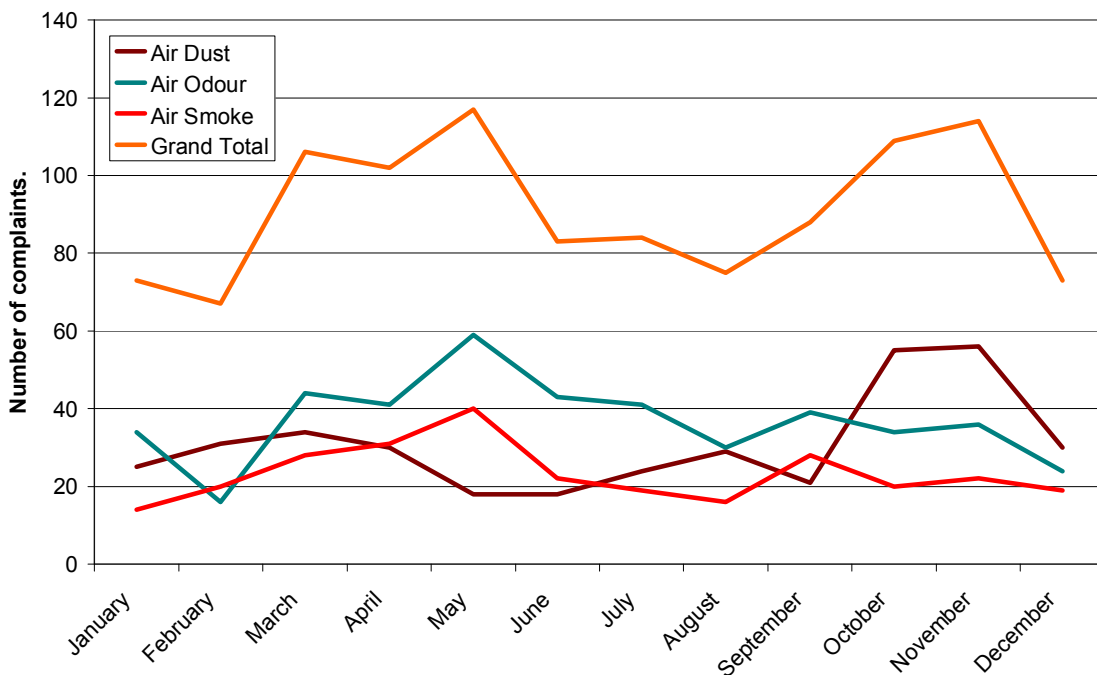

Figure 4.2 Complaint Database summary for air complaints by month, 2000-2011

Investigation of wind characteristics (Figure 4.3) shows that there is a prevailing west/south-westerly pattern which would flow across the area of interest and transport material to the residential and commercial areas to the north. Easterly wind patterns are less common, occurring normal less than 10% of the time.

³⁰ Port of Tauranga, 2009, *Port Operational Information*, <http://www.port-tauranga.co.nz/images.php?oid=1187>.

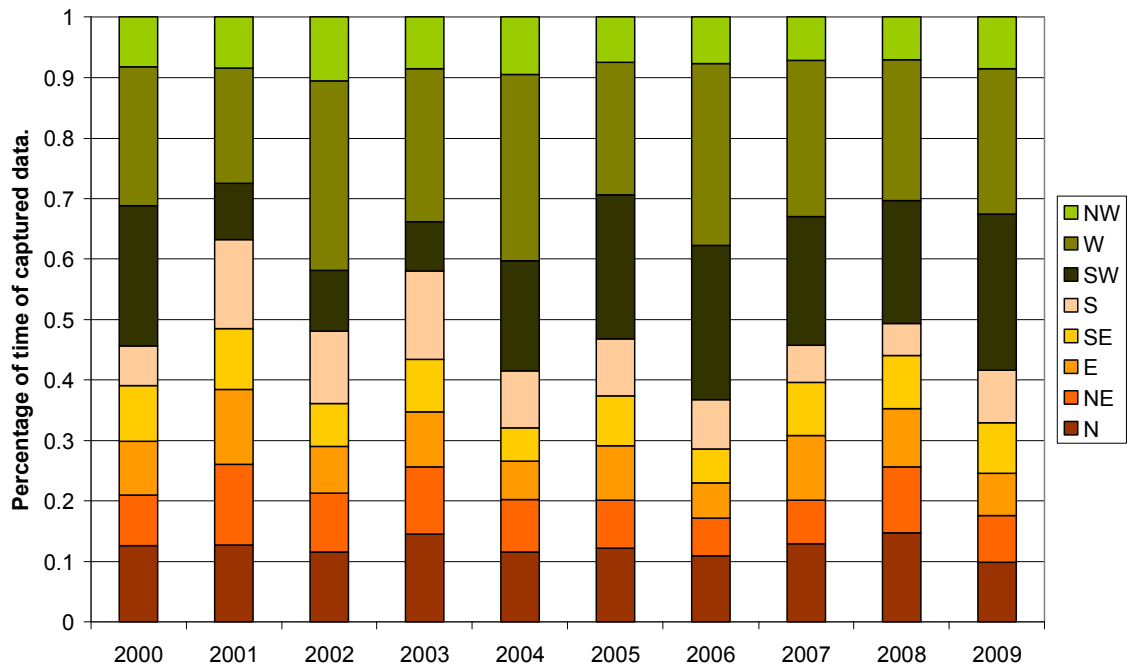

Figure 4.3 Wind direction patterns for the last decade recorded at Tauranga Aero³¹

An investigation of port export tonnage³² (Figure 4.4) which would be a rough indicator of general activity within the western zone of the Mount Maunganui area may provide further clues for the patterns exhibited within the complaints dataset, in particular those relating to dust. However an inverse relation between the two appears to exist which suggests this may not be a reliable “dust potential” indicator.

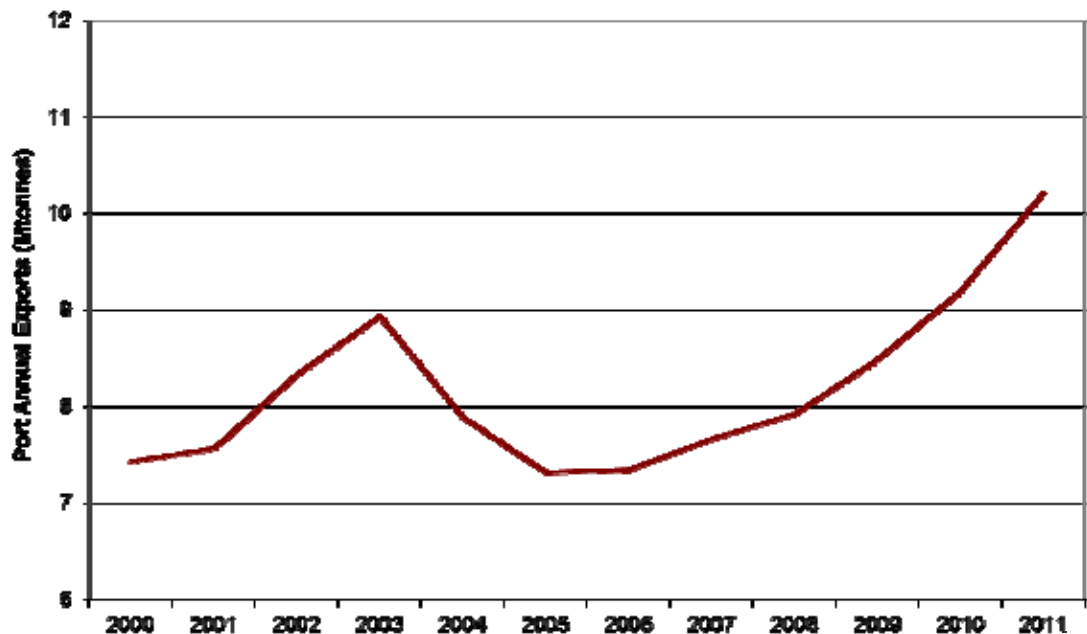

Figure 4.4 Port of Tauranga export tonnage

³¹ Tauranga Aero meteorological station data retrieved from the NIWA Cliflo database (<http://cliflo.niwa.co.nz/>).

³² Port of Tauranga, 2009, *Port Trade and Statistic Information*, <http://www.port-tauranga.co.nz/images.php?oid=1188>.

Part 5: Historical monitoring information

5.1 Historical monitoring

Historically monitoring of a range of air contaminants has been undertaken within the Mount Maunganui and wider Tauranga area.

Particulate (TSP³³ and PM₁₀) monitoring has been undertaken in 2001 and 2003. The 2001 projects were investigating complaints associated with fertiliser storage and handling and timber processing activities. The 2003 monitoring was associated with the NERMN³⁴ programme and was located on the Tauranga City side of the bridge focusing on particulate contributions from vehicular sources. A range of gas sampling has been undertaken, once again focussing on particular industrial activities.

Table 5.1 Data collection summary for the Mount Maunganui area as at January 2010

Agent	Year	Contaminant	Comment
ESR ³⁵	1995	SO ₂ , NO _x , Fluoride	Totara Street
EBOP ³⁶	2001	TSP	Maru Street (Ballance storage)
EBOP ³⁷	2001	TSP	McRae Ave (CHH)
EBOP ³⁸	2000-2001	NO _x , SO ₂ , VOC's	Totara Street
EBOP ³⁹	2000 -2003	PM ₁₀ , CO	Marsh/Chapel Street intersection
EBOP ⁴⁰	2005	H ₂ S	Te Maunga
EBOP ⁴¹	2007-present	SO ₂	Waimarie Street
EBOP ⁴²	2006	TSP	Totara Street
EBOP ⁴³	2008-present	PM ₁₀	Totara Street

See Figure 5.1 for locations of the sampling programmes outlined above.

³³ TSP – total suspended particulate, refers to particles that are suspended in air, the equipment used for TSP measurements is intended to collect all particles from less than 0.1 up to about 100 microns.

³⁴ NERMN – Natural Environment Regional Monitoring Network.

³⁵ Haly, V. M., 1995, Ambient Air Monitoring in Mount Maunganui, September to December 1994, ESR, MESC Report 95-400.

³⁶ Internal memorandum from Shane Iremonger (Environmental Data Officer) to Paula Zinzan (Environmental Field Officer), *Maru Street Dust Monitoring*, 11 June 2001.

³⁷ Internal memorandum from Shane Iremonger (Environmental Data Officer) to Paula Zinzan (Environmental Field Officer), *McRae Avenue Dust Monitoring*, 14 November 2001.

³⁸ Iremonger, S.D., 2002, NERMN Air Monitoring NO_x, SO_x, VOC's Passive Sampler Project 2000-2001, Environmental Report 2002/04, April 2002, 23p.

³⁹ Iremonger, S.D., 2008, NERMN Air Monitoring, Environmental Publication 2008/01, 74p.

⁴⁰ Environment Bay of Plenty internal data note, 2005.

⁴¹ Iremonger, S.D., 2011, Mount Maunganui Ambient Sulphur Dioxide monitoring, Environmental Publication 2011/03, 43p.

⁴² Environment Bay of Plenty internal memorandum associated coal transfer facility.

⁴³ Environment Bay of Plenty monitoring is currently ongoing with live telemetry identifying elevated values.



Figure 5.1 Current and historical monitoring sites

5.1.1 McRae Avenue

This monitoring was undertaken following complaints to determine the amount of dust that was migrating from the adjacent Fletcher Challenge Forests timber processing plant (which is located to the north) (Figure 5.2).

Results showed no samples exceeded the 150 $\mu\text{g}/\text{m}^3$ Bay of Plenty Regional Council Air Plan TSP 24-hour indicator³⁷. The highest recorded value was 95 $\mu\text{g}/\text{m}^3$ recorded on the 27 July 2001. The highest value recorded from the northerly quarter was 88 $\mu\text{g}/\text{m}^3$. The average of the recorded concentrations is 51 $\mu\text{g}/\text{m}^3$ (compared to the TSP values recorded in the Ngāpuna industrial area, Rotorua, during 1999 to 2002, where a maximum of 76 $\mu\text{g}/\text{m}^3$ and an average of 23 $\mu\text{g}/\text{m}^3$ was recorded⁴⁴).

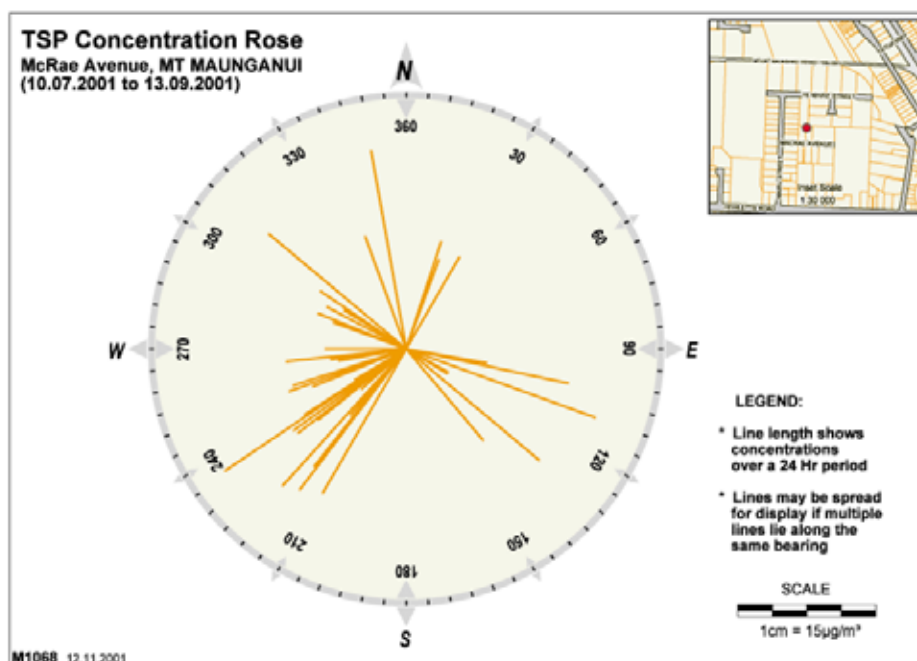

Figure 5.2 Collected TSP sample values and predominant daily wind direction during sample collection at McRae Avenue

The graphically displayed data shows high concentrations of dust associated with wind directions from a variety of directions, possibly suggesting one or several of the following:

- Multiple sources of dust in this industrial area.
- The influence of local buildings on air flows, resulting in turbulence and localised wind conditions.
- The 24-hour sampling periods didn't coincide with days when the prevailing wind was from the northerly quadrant.
- Predominant south-westerly winds carrying material away from the samplers (during the sampling days), as opposed to northerly sea breezes during summer, which may carry material towards the complainant.

⁴⁴ Iremonger, S.D., 2009, *Ngāpuna Air Quality Monitoring Report*, Environmental Publication 2009/02, Environment Bay of Plenty, 42p.

5.1.2 Maru Street

The objective of this monitoring exercise was to determine the amount of dust that was migrating from the Ballance Agri-Nutrients Ltd property on the western side of Maru Street. Dust complaints had been received from Moir Motors Ltd to the southeast of the Ballance Agri-Nutrients Ltd property (Figure 5.3).

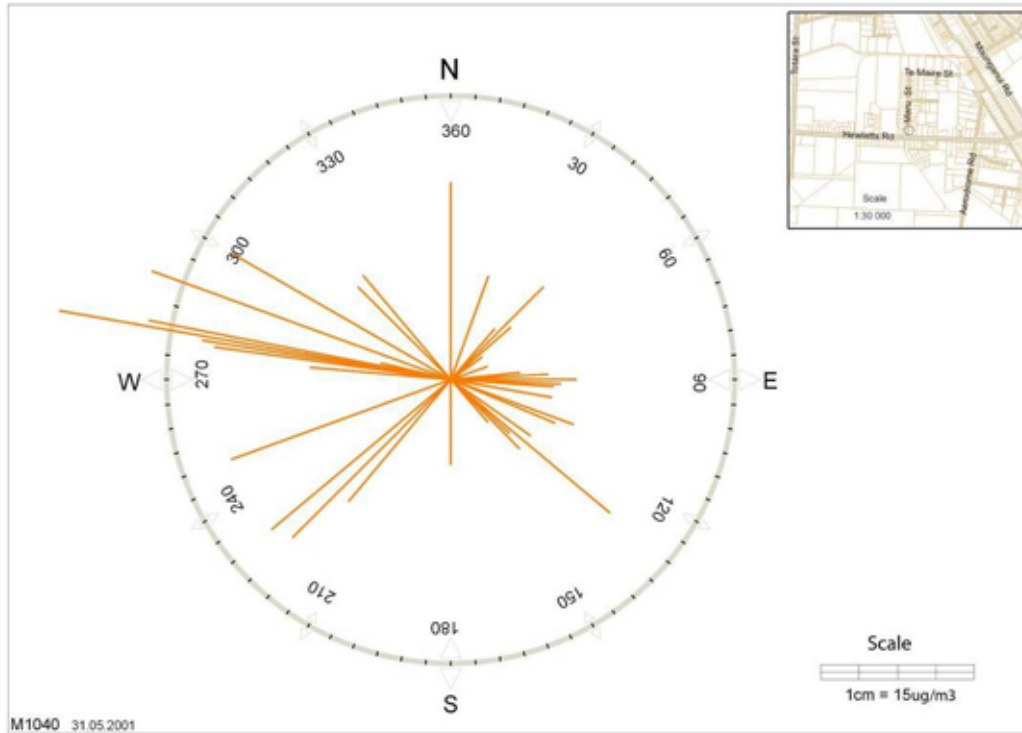

Figure 5.3 Collected TSP sample values and predominant daily wind direction during sample collection at Maru Street

The Bay of Plenty Fertiliser property was in the northwest quadrant (T) from the sampler location.

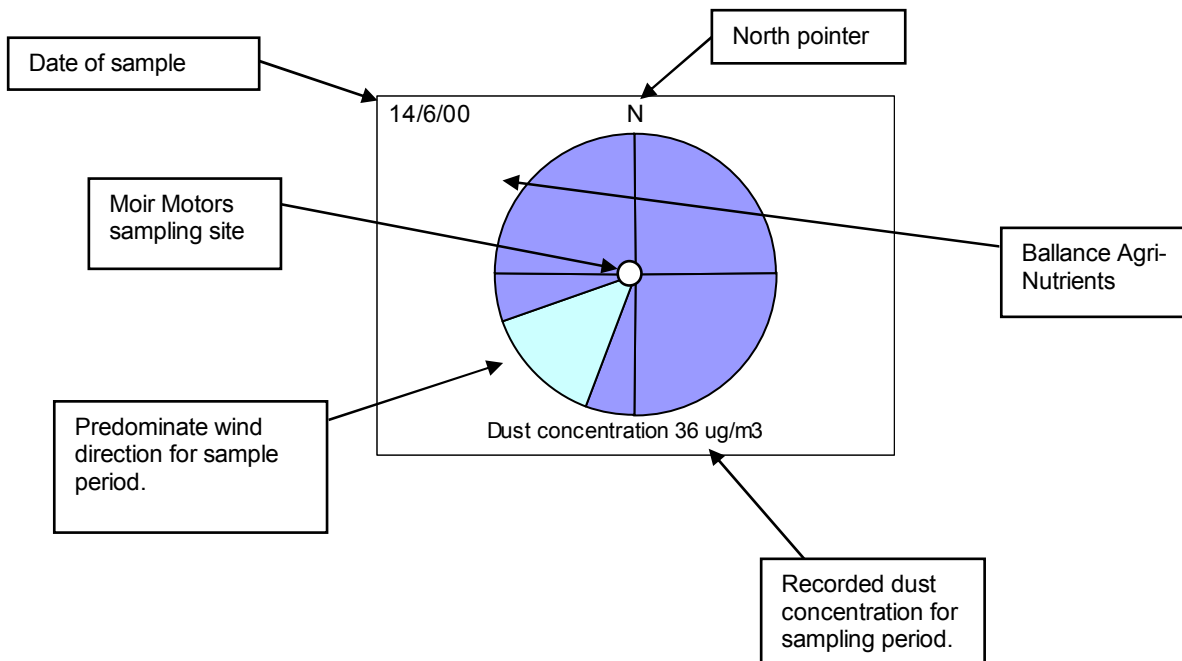

Figure 5.4 Example of data display

Forty 24-hour (midnight to midnight) samples were collected from the samplers over a period from 02 February 2001 to 11 April 2001 a sample of these is shown in Figure 5.5.

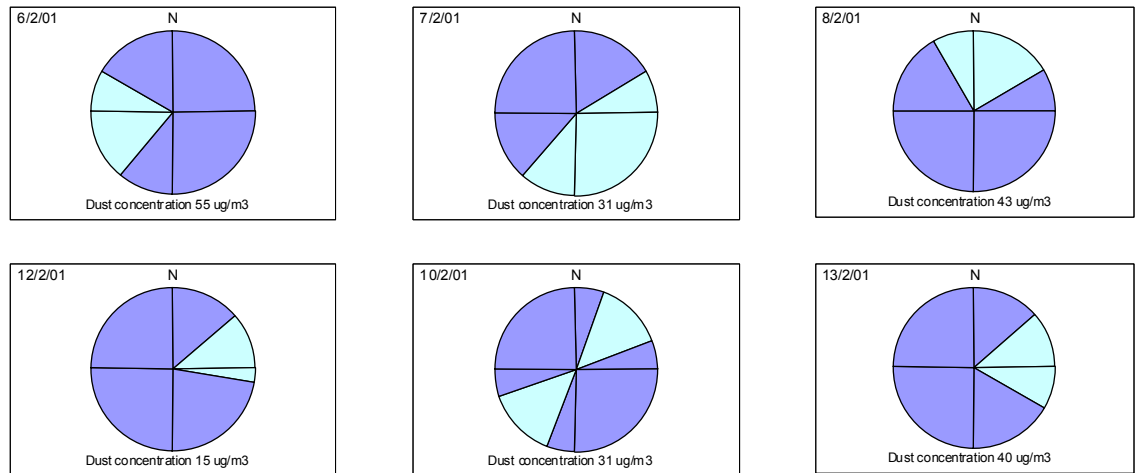

Figure 5.5 An example of the forty collected samples

In addition to wind direction analysis several samples were chosen for chemical analysis of phosphorus (from fertiliser). This analysis was undertaken by Hill Laboratories Ltd, Hamilton.

- The graphically displayed data showed high concentrations of dust associated with wind directions from the northwest and southwest quadrants.
- Samples where wind directions were predominately from the northwest and southwest quadrants show an increase in phosphorus. However phosphorous content accounts for only a small percentage of the total collected weight. This would possibly suggest a different source as to that outlined in the objective. A combination of sources (e.g. fertiliser dust from the transfer area and also other dust from the trucks using Maru Street) could be responsible for the complaint at Moir Motors Ltd.

5.1.3 Cross Road

In 2000 dust sampling was undertaken in the Cross Road area in response to activities undertaken by one of the business in the area. TSP samples were collected over the period 15/2/2000 to 13/3/2000 using Solarvol dust monitors. A total of eighteen 24-hour samples were collected over that time and the results are shown in Table 5.2.

Table 5.2 Data collection summary for the Cross Road area

Sample	TSP Value ($\mu\text{g}/\text{m}^3$)	Sample	TSP Value ($\mu\text{g}/\text{m}^3$)	Sample	TSP Value ($\mu\text{g}/\text{m}^3$)
S5	65	S11	43	S17	50
S6	98	S12	60	S18	55
S7	44	S13	84	S19	39
S8	19	S14	71	S20	44
S9	34	S15	34	S21	44
S10	48	S16	61	S22	48
Minimum	19				
Average	52				
Maximum	98				

The results are below the value ($150\mu\text{g}/\text{m}^3$ for 24 hours) listed in the Regional Air Plan (s5.6.5(c)), which is used in assessing suspended particulate matter beyond the boundary.

5.1.4 Marsh/Chapel Street intersection

This site is located at a busy Tauranga intersection servicing traffic to and from Mount Maunganui and also bypass traffic along the Waikareao Expressway.

For the majority of the time (>95%), data values fall into the Ministry for the Environment (MfE) environmental performance indicators for air quality, “Acceptable” to “Good” categories⁴⁵ (Figure 5.6).

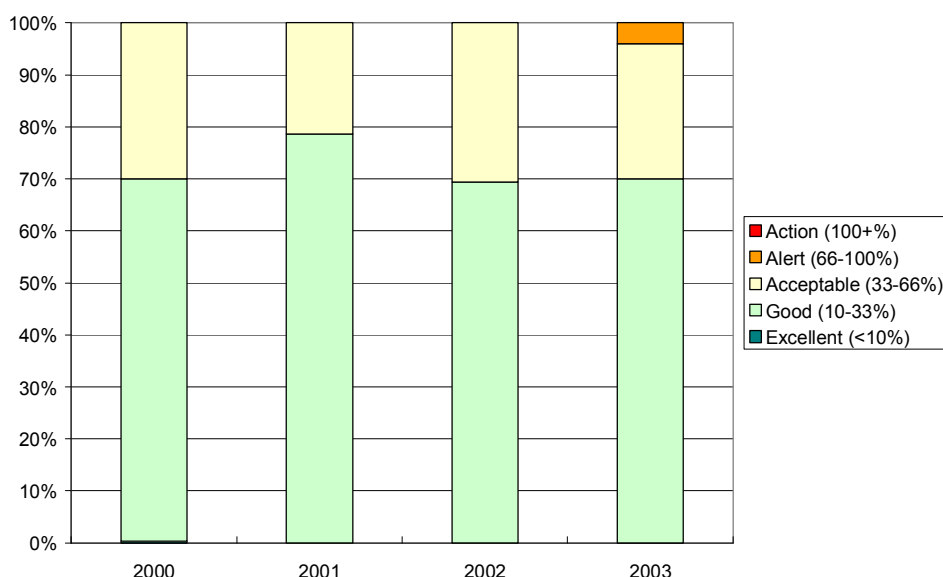

Figure 5.6 State of the air quality for PM₁₀ at the Marsh/Chapel Street intersection

⁴⁵ Acceptable, 33 – 66% of the standard, broad category, where maximum values might be of concern in some sensitive locations but generally at a level which does not warrant dramatic action.
Good, 10 – 33% of the standard, Peak measurements in this range are unlikely to impact air quality.

The diurnal plot (Figure 5.7) shows the expected morning increase associated with traffic flow. The levels remain elevated throughout the day and begin to decrease in the late afternoon. Prominent peaks in the autumn and winter plots could be linked to calmer atmospheric conditions on the cooler mornings. Sea breezes (evident in the summer concentration rose) would result in further mixing of the air mass but also means that sea spray could be present, a component of which falls into the PM₁₀ size fraction.

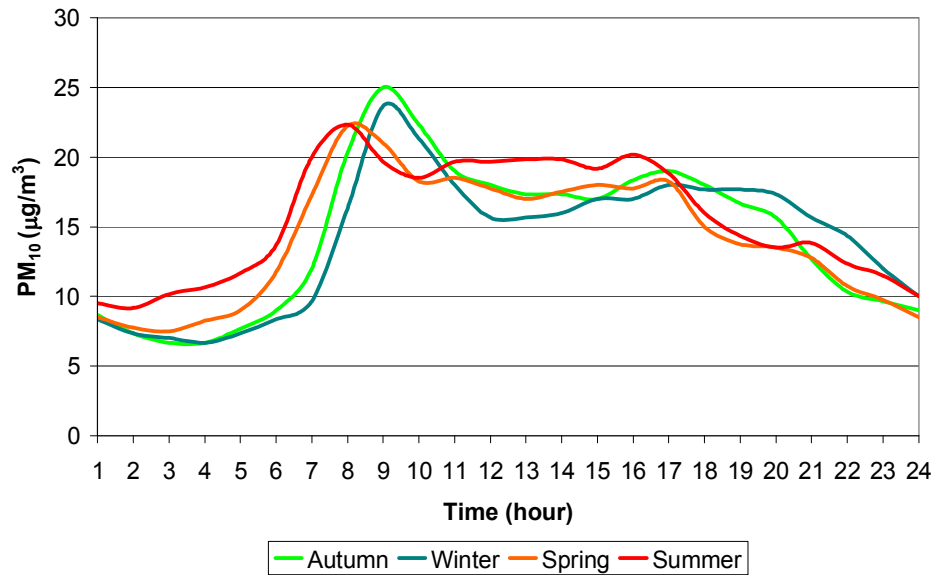

Figure 5.7 Seasonal diurnal patterns in air quality for PM₁₀ at the Marsh/Chapel Street intersection

There is no reason to suspect different patterns would exist for the Mount area. Traffic patterns would be similar and the general increases that have been seen over the last three decades would be impacting on the wider Mount area (Figure 5.8).

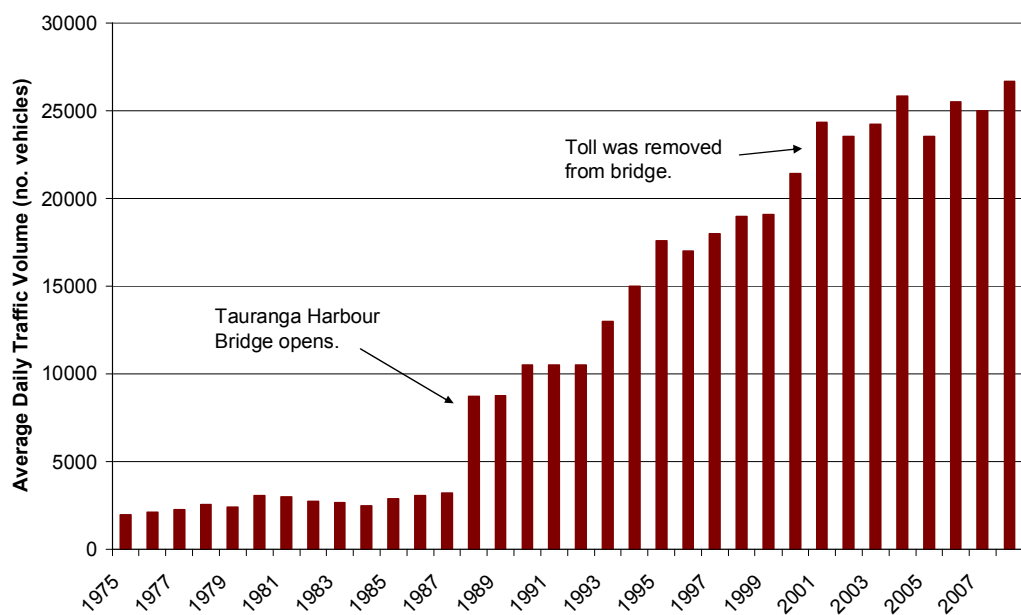

Figure 5.8 Average annual daily traffic volume for Hewletts Road (Transit site ID 02910001)

5.1.5 Totara Street

PM₁₀ monitoring has recently been undertaken at the Totara Street monitoring station (Figure 5.9). This instrument was measuring PM₁₀ and was operational from late 2008 to mid-2009. The full period average is 15.7 µg/m³ (although it should be noted the short length of monitoring due to irreparable instrumentation failure) compared to 13.7 µg/m³ and 13.8 µg/m³ at Otumoetai and Whakatāne respectively. Hence generally indicating a “dustier” environment. In contrast a full record average of 9.9 µg/m³ has been calculated from 10 years of record at the background PM₁₀ monitoring site at Pongakawa.

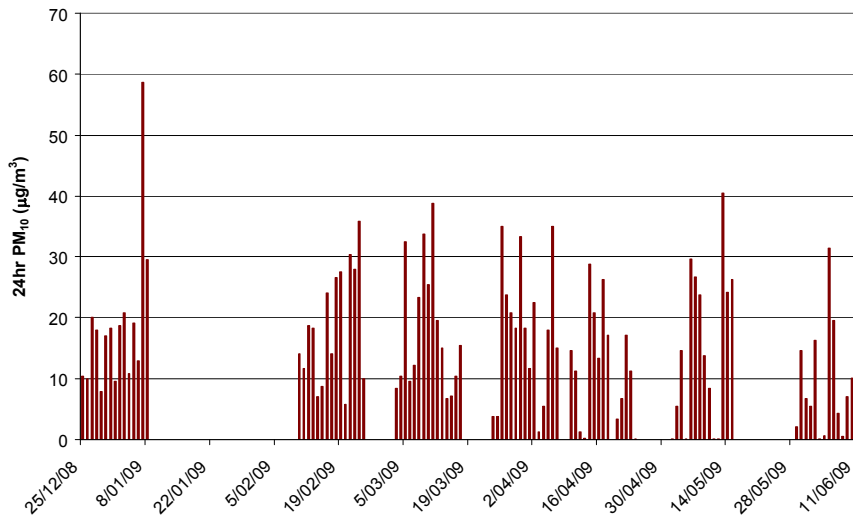

Figure 5.9 PM₁₀ data collected from the Totara Street site

One value greater than the MfE standard⁴⁶ was recorded, wind data shows several possible sources (Figure 5.10) - Ballance Agri-Nutrients, port activity, roadway traffic or the new bridge construction activities.



Figure 5.10 Wind data during for the PM₁₀ sample collected 7/1/2009

⁴⁶ One exceedance of the PM₁₀ standard is permitted per year.

5.1.6 **Historical monitoring summary**

The information presented in this section highlights the monitoring that the regional council has undertaken during the last decade. Some of the monitoring was part of the regional monitoring programme, however the majority was driven by complaints and subsequent investigations.

Elevated levels of TSP have been recorded in the 24 hour samples along with one exceedance of the NES for PM₁₀ recorded at the Totara Street site.

Part 6: Grab sample data analysis

This section of the report discusses the grab sample investigations undertaken by Bay of Plenty Regional Council in response to concerns expressed by members of the public in relation to dust nuisance in the Mount Maunganui and Sulphur Point areas.

Some of presented sub-sections are edited versions of the individual reports prepared at the time, and that some of the earlier ones have been modified to reflect our developing understanding of the different types of particles.

The sampling for these investigations involved a grab sample methodology^{47, 48, 49}. This type of sampling involves the collection of deposited material by adhesive tape or brush to pottle. Both methods have their advantages and a combination of both for each sample site is the preference. Notation of exposure period and prevailing meteorology during deposition adds value to the sample analysis. Other observations such as atypical adjacent activities are also valuable.

Primarily two types of direct sample analysis have been undertaken, the first is a visual investigation by the naked eye, the second is the use of a stereo microscope (up to 66x magnification)⁵⁰. The microscope is a Zeiss Stemi V2 with an Olympus C5000Z digital camera attachment (Figure 6.1)⁵¹. This visual examination technique looks at particle type, particle colouration, morphology and estimates of percentage representation.



Figure 6.1 Zeiss Stemi V2 stereo microscope setup with digital camera

The sites where sampling has been undertaken for this module of the investigation are shown in Figure 6.2.

⁴⁷ Hopen, T.J., 2000, *Dust Collection Method*, The Microscope Journal, 48, 213.

⁴⁸ Nichols, G., 1985, *Scotch tape magic – an aid to the microscopist for dust examination*, The Microscope Journal, 33, 247.

⁴⁹ Millette, J., 2001, *Sample collection procedures for microscopical examination of particulate surface contaminants*, The Microscope Journal, 49, 21.

⁵⁰ Hamilton, E. & Jarvis, W., *The Identification of Atmospheric Dust by use of the Microscope*, Central Electricity Generating Board Research and Development Department.

⁵¹ Kuyatt, B. & Merlo, P., 2004, *Consumer vs Scientific Digital Cameras*, Microscopy and Analysis, September 2004, p25.



Figure 6.2 Grab sample locations within the Mount Maunganui/Sulphur Point area

A third analysis method is also employed for some of these grab samples. This involves the use of a scanning electron microscope (SEM)⁵². This analysis was undertaken at Waikato University. The core of the Electron Microscope Facility is a Hitachi S-4100 Field Emission Scanning Electron Microscope with X-ray analyser. It is used for investigating structure at high magnifications and determining elemental composition of small samples. The associated software also allows for high quality imagery to be obtained.

Source apportionment⁵³ investigations based on elemental signature of bulk samples has also been used as a reference and basis for general identification in this investigation^{54, 55}.

Other physical tests such as behaviour to magnetism and elevated temperature regimes were also undertaken when necessary.

Each of the following sections represents a sample(s) from a particular location and my comments regarding this sample(s) using the techniques described above.

6.1 Open coast beach and Pilot Bay samples

These samples were collected to be used as a reference for a readily available source of natural particles (for wind transportation).

Several samples were collected from the active beach and intertidal estuarine areas surrounding Mount Maunganui. These were grab samples that were visually examined under the stereo microscope. The darker particles were also analysed using the SEM and showed Si, Mn, Ca and Al peaks (Figure 6.3).

Generally the beach sands are composed of predominantly quartz and feldspars, although volcanic glass is also a significant contributor, as a result of the volcanic origin of much of the surrounding catchment sediments. In terms of heavy minerals the relative abundance of a particular mineral species depends on the exact additions from sources. Healy et. al.⁵⁶ carried out a bulk analysis of sediment samples obtained during the Coastal Erosion Survey of the Bay of Plenty incorporating sampling from all beaches between Ōpape and Waihī Beach. In summary this work found that:

- The mineralogy was consistent with sediments sourced from rhyolite, ignimbrite and volcanic ash deposits originating from the Ōkataina and Taupō volcanic centres;
- There is a predominance of quartz and volcanic glass, although feldspars and heavy minerals are present.

⁵² The scanning electron microscope (SEM) is a type of electron microscope that images the sample surface by scanning it with a high-energy beam of electrons in a raster scan pattern. The electrons interact with the atoms that make up the sample producing signals that contain information about the sample's surface topography, composition and other properties such as electrical conductivity.

⁵³ Source apportionment - To determine contributions of various pollution sources to a location of interest.

⁵⁴ Davy, P. K., 2007, *Composition and Sources of Aerosol in the Wellington Region of New Zealand*, PhD thesis (Chem), Victoria University of Wellington, 429p.

⁵⁵ Senaratne I., Kelliher F.M. and Triggs C.M., 2005, *Source apportionment of PM₁₀ during cold, calm weather in Christchurch, New Zealand*: Preliminary results from a receptor model. Vol. 39/3 August 2005, 47p.

⁵⁶ Healy, T. R. et. al, 1977, Coastal Erosion Survey, Occasional Report No. 3, Department of Earth Sciences, University of Waikato, New Zealand, 64p.

Phizacklea⁵⁷ undertook an investigation on a central section of beach in the Bay of Plenty; the resulting beach face sediment mineralogical analysis showed the major components identified in the light fraction were plagioclase feldspar (predominantly albite), volcanic glass, quartz, and lithic fragments. The heavy minerals are dominated by hypersthene. Other heavy minerals identified include augite, green hornblende, brown hornblende, biotite, cummingtonite, apatite, zircon, olivine and aegerine (Table 6.1).

Table 6.1 Characteristics of minerals often found in coastal/estuarine sediments.

Mineral	Colour	Chemical composition
Ilmenite	Iron-black	FeTiO ₃
Albite	White to grey, bluish, greenish, reddish	NaAlSi ₃ O ₈
Augite	Dark green to black	(Ca, Na)(Mg, Fe, Al)(Si, Al) ₂ O ₆
Cummingtonite	Dark green, brown, grey, beige	(Mg, Fe) ₇ Si ₈ O ₂₂ (OH) ₂
Hornblende	Black/dark green	Ca ₂ (Mg, Fe, Al) ₅ (Al, Si) ₈ O ₂₂ (OH) ₂
Hypersthene	White, grey, green, yellow or brown	(Mg, Fe)SiO ₃
Oligoclase	Usually white, with shades of grey, green or red	(Ca, Na)(Al, Si) ₄ O ₈
Orthoclase	Colourless, Greenish, Greyish yellow	KAlSi ₃ O ₈
Titanomagnetite	Black, grey with brownish tint in reflected light	Fe ₃ O ₄
Zircon	Reddish brown	ZrSiO ₄
Olivine	Yellow to yellow-green	(Mg, Fe) ₂ SiO ₄
Aegerine	Dark Green, Greenish Black.	NaFe ₃ +[Si ₂ O ₆]
Apatite	Transparent to translucent, usually green.	Ca ₅ (PO ₄) ₃ (F, Cl, OH)

For the samples collected (Figure 6.3) the colourless or white grains will be quartz, plagioclase feldspar, and there might be a few grains of colourless clear volcanic glass. The pale green to darker green coloured grains are probably hypersthene (dark green), cummingtonite (pale green - derived from the Rotoehu Ash), and hornblende (very dark green). The brown grains will likely be small rock fragments of rhyolite. The dark grey to black grains are probably rock fragments, e.g. andesite or rhyolite. The really black grains will be opaque minerals like titanomagnetite and ilmenite. To do any more detailed work would require examination under a petrographic polarising microscope which is beyond the scope of this investigation.

The particles seen in these two samples (Pilot Bay beach and open coast beach east of Moturiki Island) typically make up the base particle profile for many of the grab samples collected and reported on in the following sections of this report. The difference being the particle size, the grab samples generally exhibit the finer fraction version of these beach particle profiles.

⁵⁷ Phizacklea, D. J. D., 1993, *Littoral sediment budget and beach morphodynamics, Pukehina Beach to Matata, Bay of Plenty.*, MSc thesis, University of Waikato, 321p.

Pilot Bay

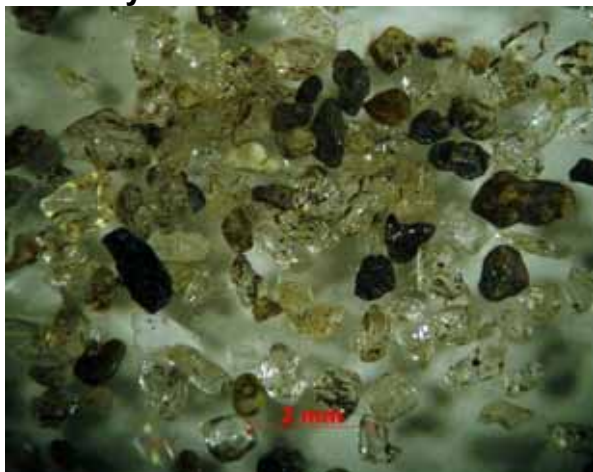

Open coast

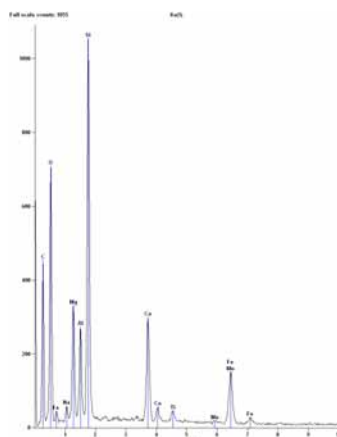
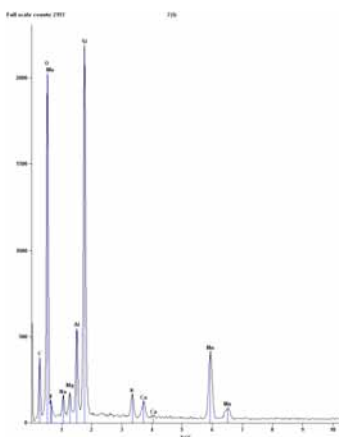
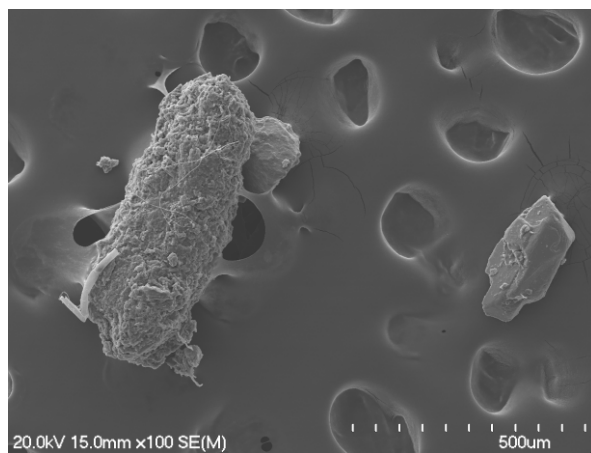
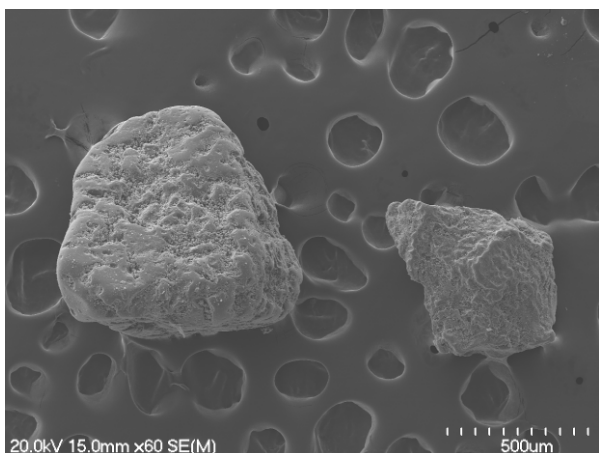
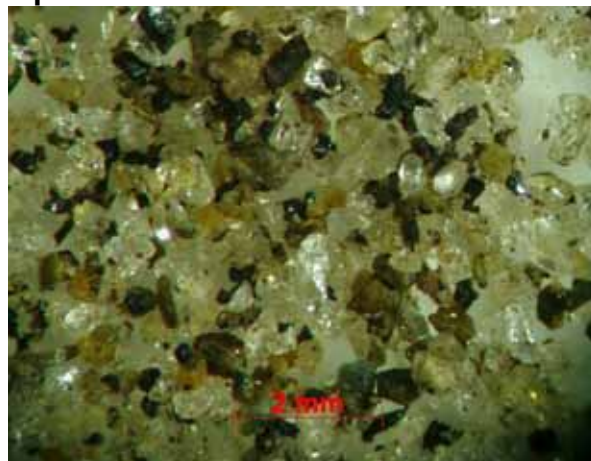

Figure 6.3 Open coast and Pilot Bay samples

6.2 Tawa and Miro Street, 2006

6.2.1 Background

Dust complaints were received from residential properties in Tawa and Miro Street, Mount Maunganui in December 2006.

Complainants identified the nearby coal storage area as a potential source of the deposited material. The storage area is approximately 250 m to the west of the complainants. A graphical description of the coal transfer procedure is shown in Appendix 3.

Two independent types of analysis were performed during this investigation.

6.2.2 Analysis one

Methodology

Photomicrography was performed by Dr Bruce Graham on grab samples collected from the complainant's property (for full report see Appendix 2). The samples represented material collected over a period of 1-2 weeks.

Results

Dr Graham concluded that the photomicrographs indicate that the properties in Miro and Tawa Streets are both being affected by coal dust, and the most likely source of this fallout is the coal handling facilities at the port, immediately adjacent to Totara Street.

6.2.3 Analysis two

Scanning Electron Microscope analysis was performed on samples collected from Bay of Plenty Regional Council total suspended particulate (TSP) monitoring equipment to determine if any coal material was present.

Methodology

Four TSP monitors were located at several points within the area of interest. The samplers were set to sample for a period of days following the unloading of the coal transporting vessel - Lodestar Princess (arrived 7/8/2006, departed 9/8/2006). Periods of TSP sampling are shown in Table 6.2. Sampling periods were also chosen with respect to forecasted weather conditions. Analysis of the wind conditions (Figures 6.4 to 6.7) during sampling periods show the dominant westerly winds are generally consistent with dust being blown from the coal handling areas and towards the complaints' (Figure 6.4 being the exception).

Collected samples were then analysed at the University of Waikato SEM facility. A representative sample was also collected from the coal store for comparison.

Table 6.2 Sample numbers, dates and location

Sampling dates	Location ⁵⁸			
	017	018	019	020
04/8/06 – 07/8/06	E10-017	E10-018	E10-019	E10-020
10/8/06 – 12/8/06	E2.5-022	E2.5-021	E2.5-020	E10-016
17/8/06 – 19/8/06	E10-036	E10-037	E2.5-024	E2.5-023
22/8/06 – 26/8/06	E10-41	E10-040	E10-039	E10-038

⁵⁸ 017 – At the BOPRC Totara Street monitoring site.

018 – Inside the POT boundary on Totara Street next to the load out silos

019 & 20 – Within the Tawa/Miro Street residential area.

Site 766204 Tauranga Aero AWS wind speed/direction

3-Aug-2006 to 8-Aug-2006



Figure 6.4 Wind rose for first sampling period

Site 766204 Tauranga Aero AWS wind speed/direction

9-Aug-2006 to 12-Aug-2006



Figure 6.5 Wind rose for second sampling period

Site 766204 Tauranga Aero AWS wind speed/direction

16-Aug-2006 to 19-Aug-2006

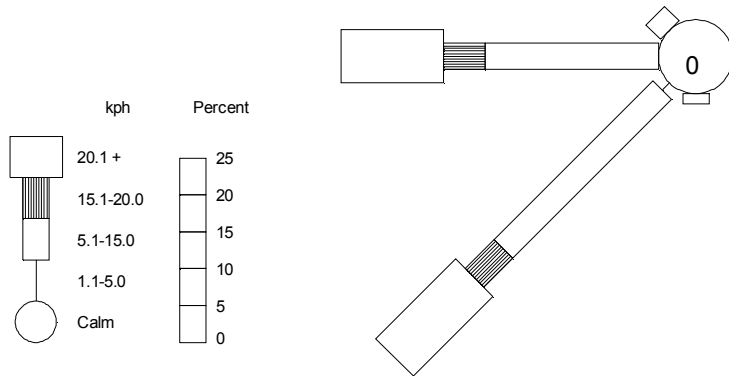

Figure 6.6 Wind rose for third sampling period

Site 766204 Tauranga Aero AWS wind speed/direction

21-Aug-2006 to 26-Aug-2006

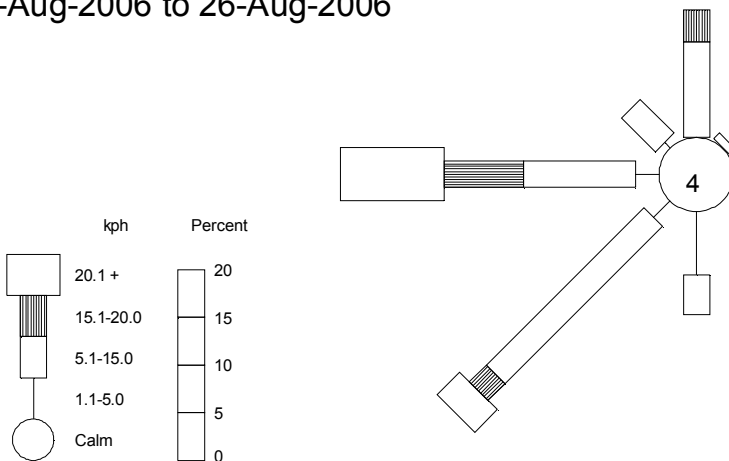

Figure 6.7 Wind rose for fourth sampling period

Results

The results of the University of Waikato SEM investigation are outlined in the covering letter dated 29/11/06, a summary of which is outlined below:

- Each sample was examined extensively and then a series of images and analyses were captured. The images show typical particles, the spectra for which are also included although in some cases they are simply general to all particles analysed during examination.
- A spectrum typical of the coal shed material was not seen for any of the samples, which strongly suggests that coal dust was not present on any of the supplied filters.

The coal shed sample results⁵⁹ are shown in Figure 6.8. As expected a dominant carbon signature is evident. Along with visual identification these characteristics were used as the standard for coal when comparing with the material collected on the TSP samples.

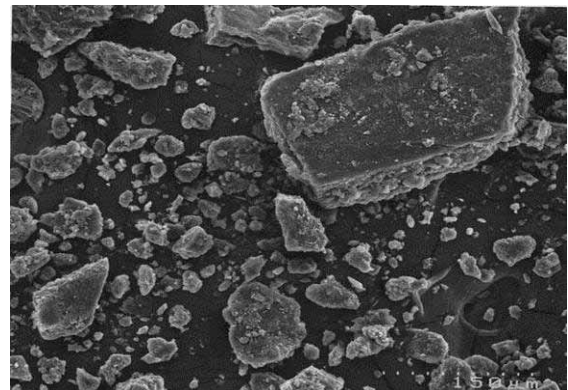
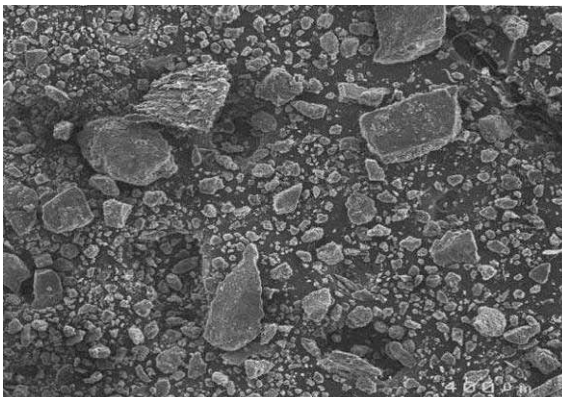
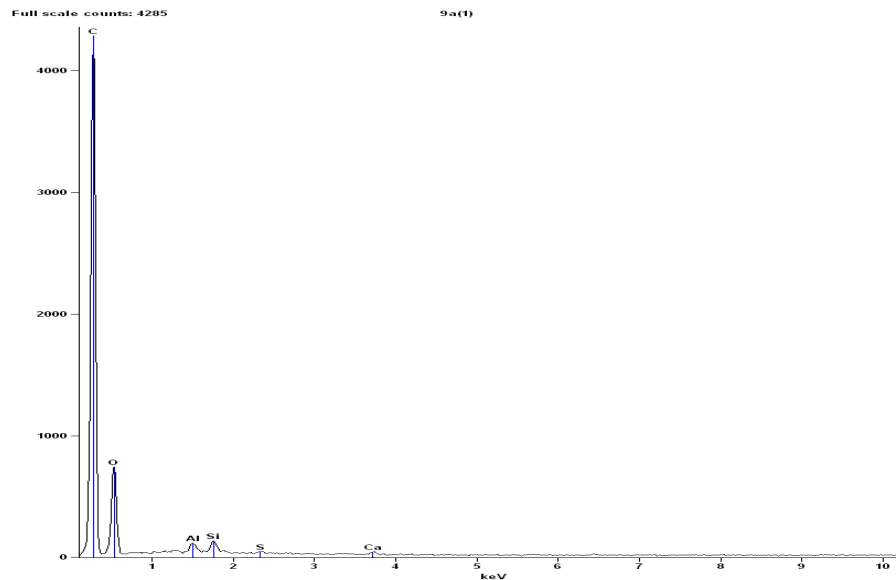

Figure 6.8 SEM spectra and visual output for Coal Shed sample (note - dominant carbon signature)

⁵⁹ During the course of this investigation several reference samples have been collected from the coal storage shed. They all have the same general characteristics. Figure 6.8 is used as the reference for this report. See Figure 6.18 for photomicrographs of the coal sample.

The dominant elements that were identified for each collected sample are listed in Table 6.3. Further identification of potential sources based on the spectra from representative particles for each sample can be partially achieved by using results from source apportionment investigations. For sea salt or marine sources, Na, Cl, Ca, Mg, K and S can be dominant elements. Si, Al, Cl and Ca can be dominant elements for road dust sources. C and K are dominant elements for wood combustion. C, S and Al can be dominant elements for motor vehicle sources.

Table 6.3 Dominant elements detected.

Sample				
Sampling dates	Location			
	017	018	019	020
4/8/06 – 7/8/06	E10-017 Si, Cl, Al, K, Ca	E10-018 Si, Al, Cl	E10-019 Cl, Na	E10-020 Si, Al, Cl, Fe
10/8/06 – 12/8/06	E2.5-022 Si, Al, Ca	E2.5-021 P, Si, Ca F	E2.5-020 Cl, Na, Mg, Si, Al	E10-016 Ca, Cl, Si, F, P, Na
17/8/06 – 19/8/06	E10-036 Si, S, Ca, Cl, C, Al	E10-037 S, Si, C, Al, Cl, K	E2.5-024 Cl, Si, Mg, Fe, Ca, Ti, S, F	E2.5-023 -
22/8/06 – 26/8/06	E10-41 Si, Ca, Al, K	E10-040 Si, Cl, Al, S	E10-039 Si, Ca, Cl, S, Al	E10-038 -

Discussion

The focus of this investigation was to determine if there was any coal dust migrating from the storage and transfer area at the Port of Tauranga across neighbouring properties (particularly to the east).

Initial sample analysis performed by Dr Graham using photomicrography images highlighted that complainant's properties were being affected by coal dust based on samples collected from surfaces in May and June 2006.

Further TSP samples collected by Bay of Plenty Regional Council during August 2006 were analysed using SEM technology and showed no evidence of coal particles present. This sampling was undertaken at a time where winds are consistent with dust being blown from the coal handling areas and towards the complaints and also the arrival and unloading of a coal shipment and loading of the train carriages.

As with all ambient particulate monitoring programmes slight variations in meteorological conditions and the location of the equipment can result in the non-detection collection of emissions from specific sources. To try and address this potential shortcoming, a TSP sampler (Site 018) was placed just inside the boundary fence of the storage and transfer facility (adjacent to the transfer tower). The collected filters from this sampler showed no evidence of coal particles.

Prior to the TSP monitoring several Bay of Plenty Regional Council staff visited the coal storage site (20/7/06). An inspection of the process was undertaken and several locations were highlighted as potential leakage points. Prior to the TSP monitoring, work was underway to enclose these areas, in particular the conveyor belt ends, the western side of transfer tower (T2) and a 1 meter gap in the conveyor belt enclosure between T2 and the conveyor system leading to the rail loadout silos. During this visit there was no visual evidence of localised soiling from coal dust on any structures surrounding the coal storage/transfer area.

Analysis of the SEM results points to there being other sources of particulate material within this area, natural sources (sea spray), general sources from port and light industrial activities, potential fugitive emissions from unsealed areas within the port area and emissions from vehicle activity on the adjacent Totara Street (100 m to the west).

6.3 **Mount Maunganui Cosmopolitan Club, Miro Street**

The following notes provide an assessment of a dust sample collected by Kelly Baxter from the air conditioning filter unit at the Cosmopolitan Club in Mount Maunganui on 27 September 2006. Filters are changed/cleaned approximately every 2-3 weeks.

The Club is located approximately 280 metres to the east of the coal transfer area.

These notes are based on examination of the photomicrographs taken of the sample.

The photomicrographs (Figures 6.9 and 6.10) showed a mixture of grey, brown and white particles, as expected for general urban dust, and a small proportion (<5%) of black particles.

Most of the particles in the sample were less than about 100 microns, although there were a few larger than this, up to about 200 microns. The presence of particles up to 100 microns in size indicates that this portion of the dust was most likely generated within less than 100 metres of the sample collection point, although greater travel distances are possible under high wind conditions and with re-suspension processes acting on the particles. In addition, the smaller particles may be carried over greater distances.

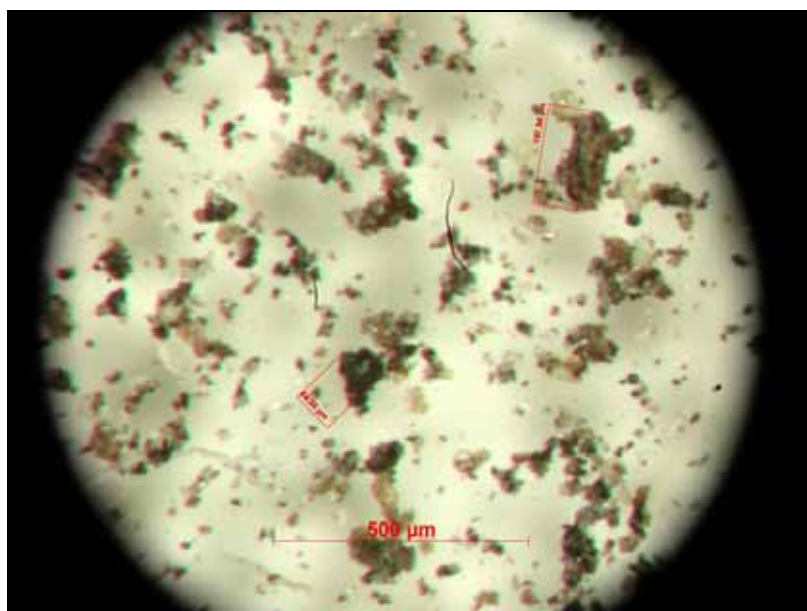

Figure 6.9 *Cosmopolitan Club sample collected on 27/9/06*

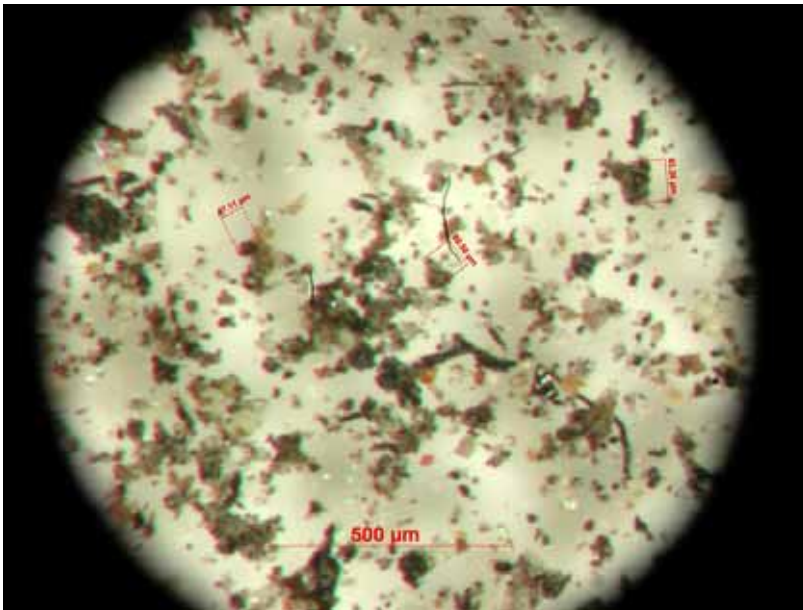

Figure 6.10 Cosmopolitan Club sample collected on 27/9/06

Discussion

The photomicrographs indicated that the Cosmopolitan Club property was predominantly being affected by general urban dust. There was a small proportion (<5%) of the sample which could potentially be classified as coal based on this visual examination.

6.4 Pitau Road, 2007, No.1

The following notes provide an assessment of a dust sample collected by Kelly Baxter from a residential property at the western end of Pitau Road in Mount Maunganui on 24 April 2007. The complainant reported that the dust had been deposited recently (in the order of days) and suspected that it was from the coal transfer facility.

The northern end of Pitau Road is located approximately 900 metres to the north of the coal transfer area where the trains get loaded and 1300 metres north of the coal storage shed.

Meteorology

Figure 6.11 summarises the wind data collected at the Totara Street meteorological station. Data shows that wind was from the south/southwest approximately half of the time in the week prior to sample collection. Wind from the south would be on the correct wind line to possibly transfer particulate matter from the port area (but only the finer fraction (<10 μm) due to the distances involved).

Site 2621 Totara St caravan at Tauranga

16-Apr-2007 to 25-Apr-2007

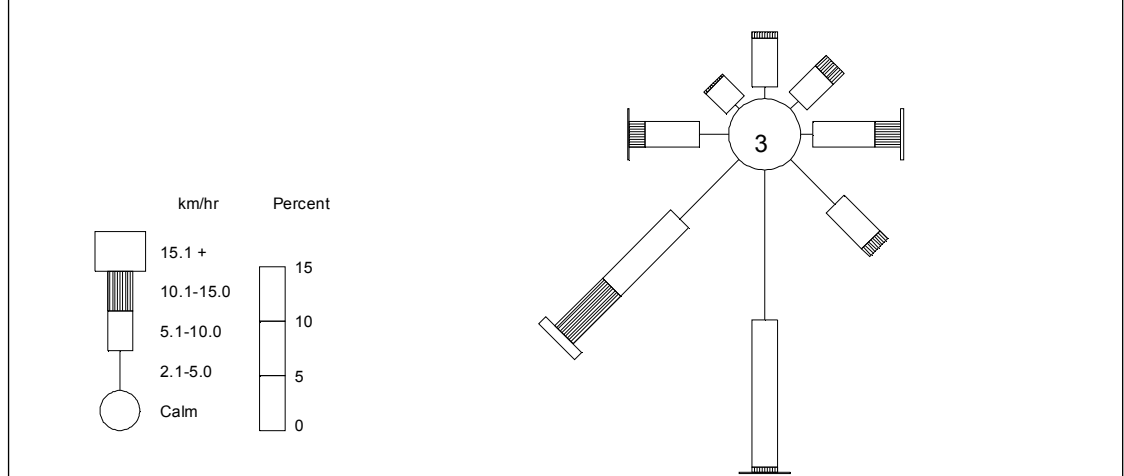

Figure 6.11 Wind rose for 17 April 2007 to 25 April 2007

The following notes are based on examination of the photomicrographs taken of the collected sample.

The photomicrographs (Figures 6.12 and 6.13) showed a mixture of grey, brown and white particles, as expected for general urban dust (similar to samples collected in 2006 from Miro and Tawa Street properties), and a proportion (~50%) of black particles. These black particles had a general globular structure as opposed to the angular particles in the coal storage shed sample (see Figure 6.8). The globular nature of these particles suggested a combustion origin (possibly shipping emissions).

Most of the particles in the sample were less than about 100 microns. The presence of particles up to 100 microns in size indicates that this portion of the dust was most likely generated within 100m of the sample collection point, although greater travel distances are possible under high wind conditions. In addition, the smaller particles may be carried over greater distances.

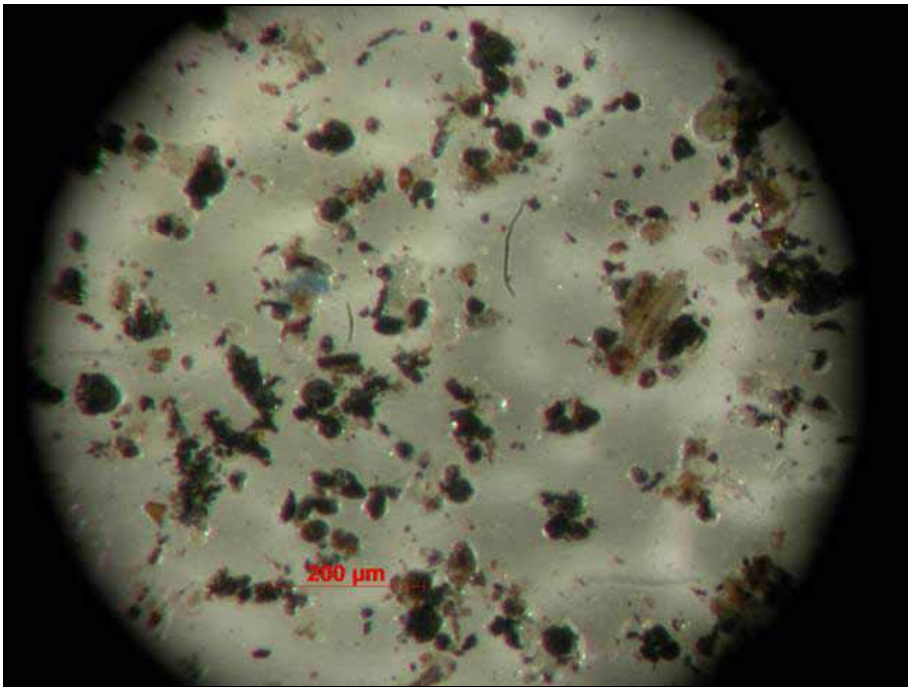

Figure 6.12 Pitau Road sample collected on 24/4/07

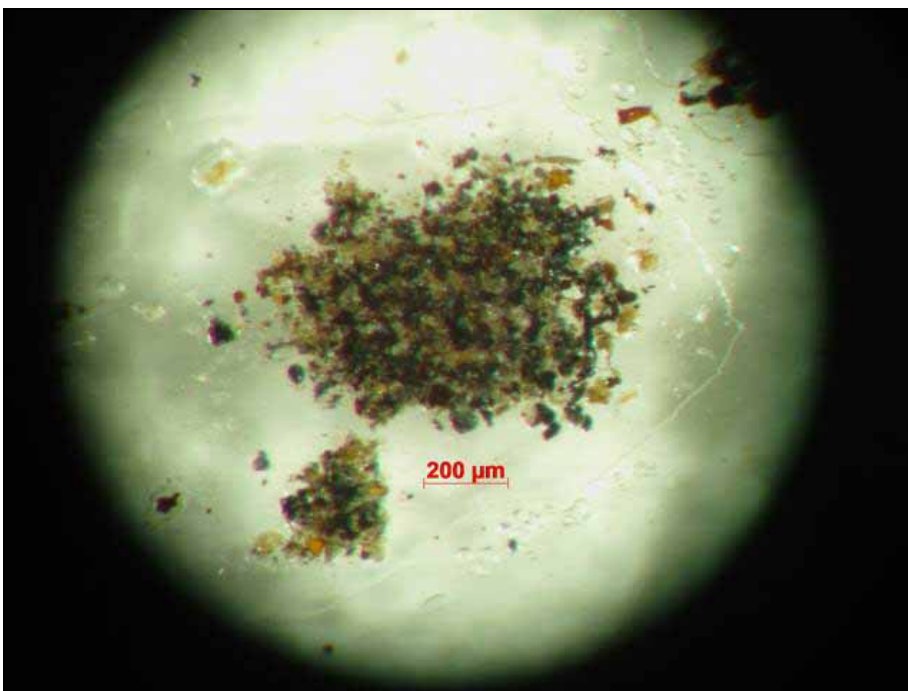

Figure 6.13 Pitau Road sample collected on 24/4/07

Conclusion

The photomicrographs indicated that the Pitau Road property was being affected by general urban dust, but there was also a proportion (~50%) of black particles which could be classified as arising from an unidentified combustion source.

6.5 Pitau Road, 2007, No. 2

6.5.1 Background

Dust complaints were received from a residential property at Pitau Road, Mount Maunganui (Figure 6.2).

The complainant identified the coal storage/transfer area as a potential source of the deposited material. The coal facility is approximately 800 m to the south of the complainant's property.

Previous investigations

6.5.2 Methodology

The collection methodology differs from that used in the previous investigation where a 'grab' sample was collected from a deck surface. The approach for this investigation was to use total suspended particulate (TSP) monitoring equipment.

Three ambient air samples were collected from the Bay of Plenty Regional Council samplers located on the complainant's property. Samples were collected over the period 19 June to 16 July 2007. Samples were typically collected over a period of 3-4 days each.

These samples were then inspected using two methods, (i) standard stereo microscope and (ii) scanning electron microscope.

6.5.3 Ancillary information

A representative sample from the coal storage shed had been collected during earlier investigations and is used as a reference for this source and for comparative analysis as described in 6.2.3.

The reference coal shed sample results are shown in Figure 6.8. As expected a dominant carbon signature is evident. Along with visual identification these characteristics were used as the standard for coal when comparing with the material collected on the TSP samples.

Wind data (from the Totara Street meteorological site) and daily rainfall totals (from a Tauranga Harbour rain gauge) recorded during the period of interest were also investigated.

6.5.4 Results

6.5.5 Standard stereo microscope

The collected filters showed two dominant categories of particle size. One group of larger particles was in the 20 to 60 μm size range and had dark colouration and irregular and often angular profiles. A group of smaller particles ($<10 \mu\text{m}$) was also present. These particles were at the lower visible limit of the microscope. Part of this group were finer particles that discoloured the teflon filter media (lighter patterns are evident in the imagery from where the filter holder touches the filter) (Figure 5.26).

Sample concentrations range from 22 to 39 $\mu\text{g}/\text{m}^3$.

6.5.6 Scanning electron microscope

The results of the SEM investigation are shown in the following summary tables (Table 6.4 to 6.6).

Each sample was examined extensively and then a series of images and analyses were captured. The images show typical particles, although in some cases they are simply general to all particles analysed during examination.

It can be seen that an elemental signature typical of the coal shed material was not seen for any of the subsequent samples which strongly suggests that coal dust was not present on any of the (supplied) filters.

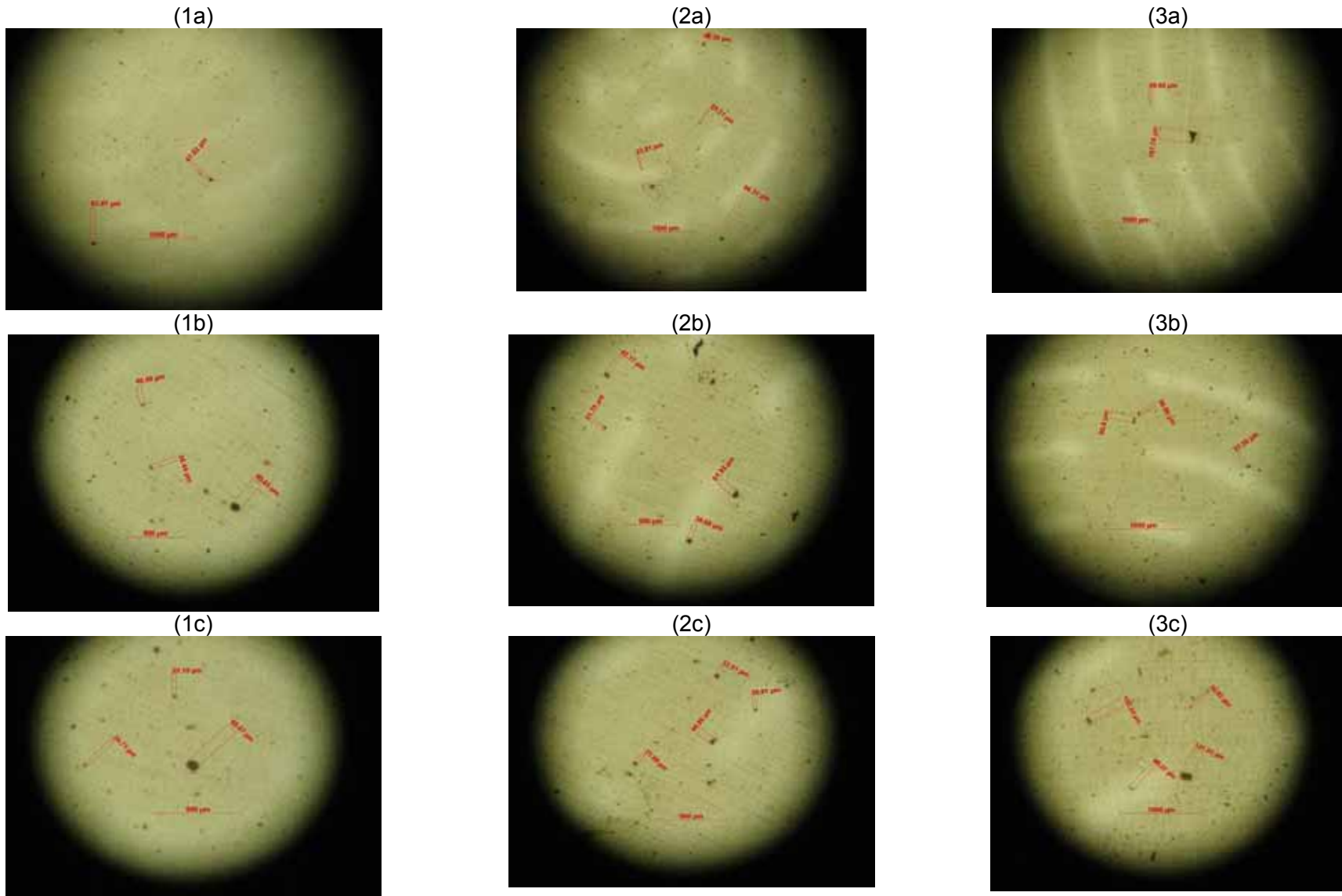
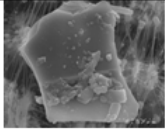
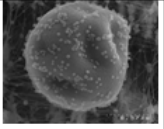
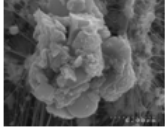
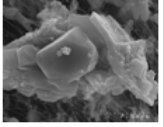
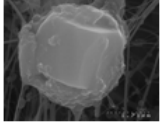
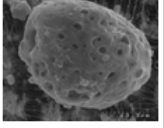
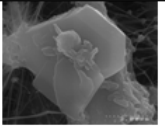
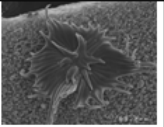
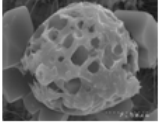
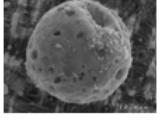
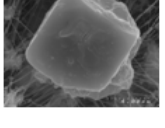

Figure 6.15 Standard microscope images of the Sample 1 (#87) Sample 2 (#88) and Sample 3 (#89)

Table 6.4 Pitau Road, sample 87 results

Sample Number	Sample Dates	Selected Particle	Dominant elements detected.	SEM image	Selected Particle	Dominant elements detected.	SEM image
87	19 – 21 June 2007	87A	Si, K, Al		87H	C, O, Cl, K	
		87B	Cl, Si, Al		87J	Cl, Na	
		87C	Cl, Na		87K	C, S	
		87D	Cl, Na		87L	C, O, Cl, K, Ca	
		87E	Cl, Mg, Si		<p>Comments:</p> <p>The dominant elements that were identified for each particle are listed. Further identification of potential sources based on the spectra from representative particles for each sample can be achieved by using results from source apportionment investigations.</p> <p>For sea salt or marine sources Na, Cl, Ca, Mg, K and S can be dominant elements. Many of the analysed particles have significant components of these elements, which due to the proximity of the sample site to the coastal environment this is not surprising.</p> <p>Particles A and B register dominant elements for road dust sources.</p> <p>Wind direction shows a predominance of west-south-westerlies during the sampling period. ~15% of the time were moderate strength winds coming from the sea.</p>		
		87F	S, C, F				
		87G	Cl, Na				

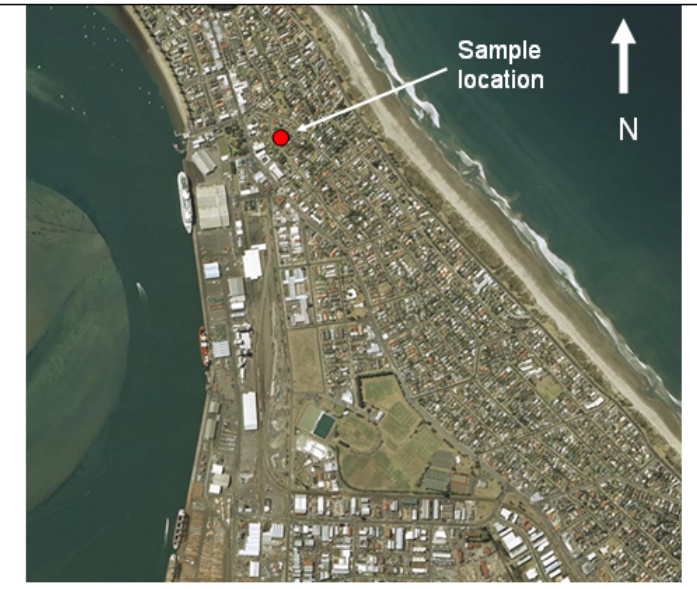
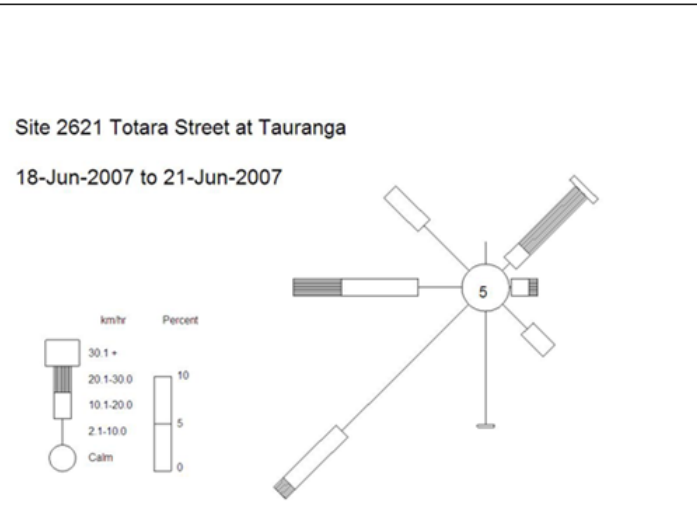

Table 6.5 Pitau Road, sample 88 results

Sample Number	Sample Dates	Selected Particle	Dominant elements detected.	SEM image	Selected Particle	Dominant elements detected.	SEM image		
88	3 – 6 July 2007	88A	F, Fe, Si, Cl		88H	Si, Al			
		88B	Si, Al		88J	S, Cl, C			
		88C	C, O, Cl		88K	Pine pollen			
		88D	Si, Al, Ca		88L	Pollen			
		88E	Si, Al		88M	Si, Al, Cl, Fe			
		88F	Cl, Si, Na		Comments: As with Sample 87 this sample contains particles of a marine origin. Typically crystalline salt structures. There is also the presence of particle with signatures typical of road dust (D, E, F and H).				
		88G	Ca, Cl, S, P		C, S and Al can be dominant elements for vehicle sources. Pine and other pollens were also present in this sample. Wind direction shows a predominance from the west/northwest.				
		<div style="display: flex; justify-content: space-between;"> <div style="width: 45%;"> <p>Site 2621 Totara Street at Tauranga 2-Jul-2007 to 6-Jul-2007</p>  <p>km/hr Percent</p> <ul style="list-style-type: none"> 30.1+ 15 20.1-30.0 10 10.1-20.0 5 2.1-10.0 0 Calm </div> <div style="width: 45%;">  <p>Sample location</p> <p>N</p> </div> </div>							

Table 6.6 Pitau Road, sample 89 results

Sample Number	Sample Dates	Selected Particle	Dominant elements detected	SEM image	Windrose for sampling period
89	26 - 29 June 2007	89A	Si, Al		<p>Windrose for sampling period</p> <p>Plotted 14-SEP-2007 11:33</p> <p>Site 2621 Totara Street at Tauranga 25-Jun-2007 to 29-Jun-2007</p>  <p>Comments:</p> <p>Sample 89, six dominant particle types were identified. Particle 89D is a natural oddity.</p> <p>The dominant elements that were identified for Sample 89 are listed. Further identification of potential sources based on the spectra from representative particles for each sample can be partially achieved by using results from source apportionment investigations. For sea salt or marine sources Na, Cl, Ca, Mg, K and S can be dominant elements. Si, Al, Cl and Ca can be dominant elements for road dust sources. C and K are dominant elements for wood combustion. C, S and Al can be dominant elements for motor vehicle sources.</p> <p>As with the previous two sample (87 & 88) there is a presence of marine (sea salt) and road dust elemental signatures for the dominant particles shown.</p> <p>Sample 89G represents the larger size particles (~50µm) that were visible in the stereo microscope imagery. When compared with the elemental spectrum for the coal shed sample (see Figure 3) it shows that 89G is missing the key Si and Al peaks.</p> <p>The wind rose shows the prevailing wind for the sampling period for 89 to be from the south/southwest, although wind speed were deemed light with the greatest percentage of time being less than 10kph.</p>
		89B	Si, Al, Ca		
		89C	Si, Al, K		
		89D	F, S		
		89E	Cl, Na (cube). Si, Al (rest).		
		89F	S, C, F		
		89G	C, O, Cl		

6.5.7 Ancillary information

Rainfall

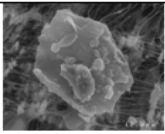
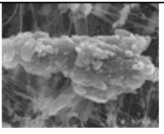
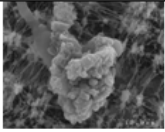
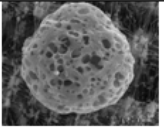
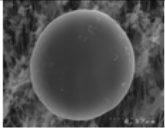
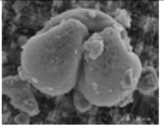
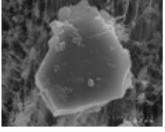
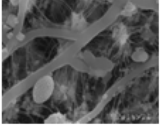
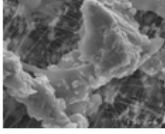
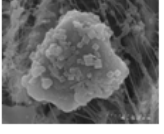
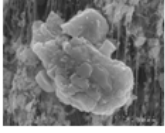
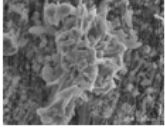
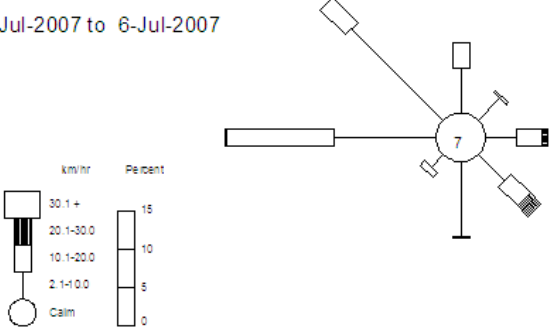
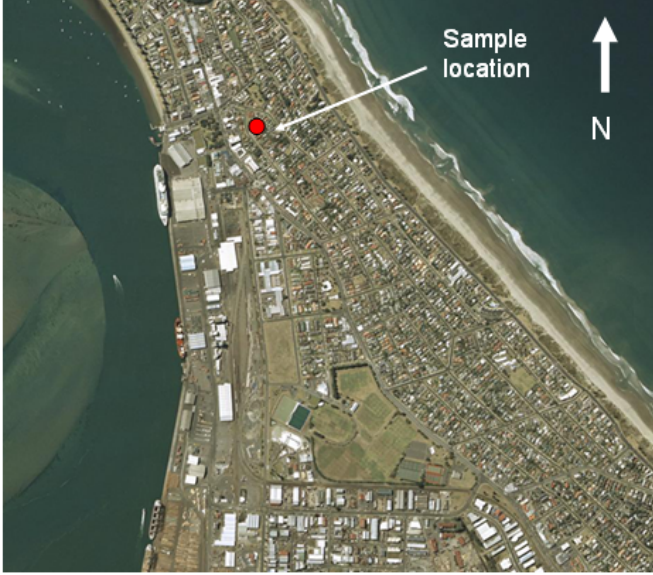
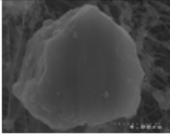
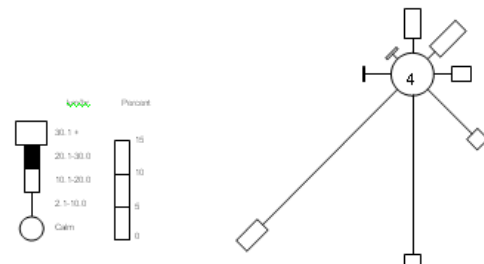
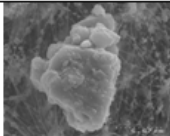
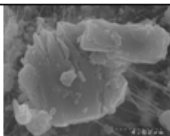
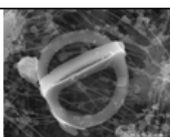
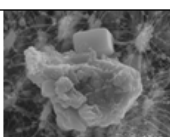
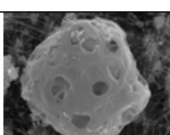
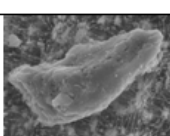
Moderate daily rainfall totals were recorded during each of the sampling periods (Figure 6.16). This would suppress the quantity of airborne particles.

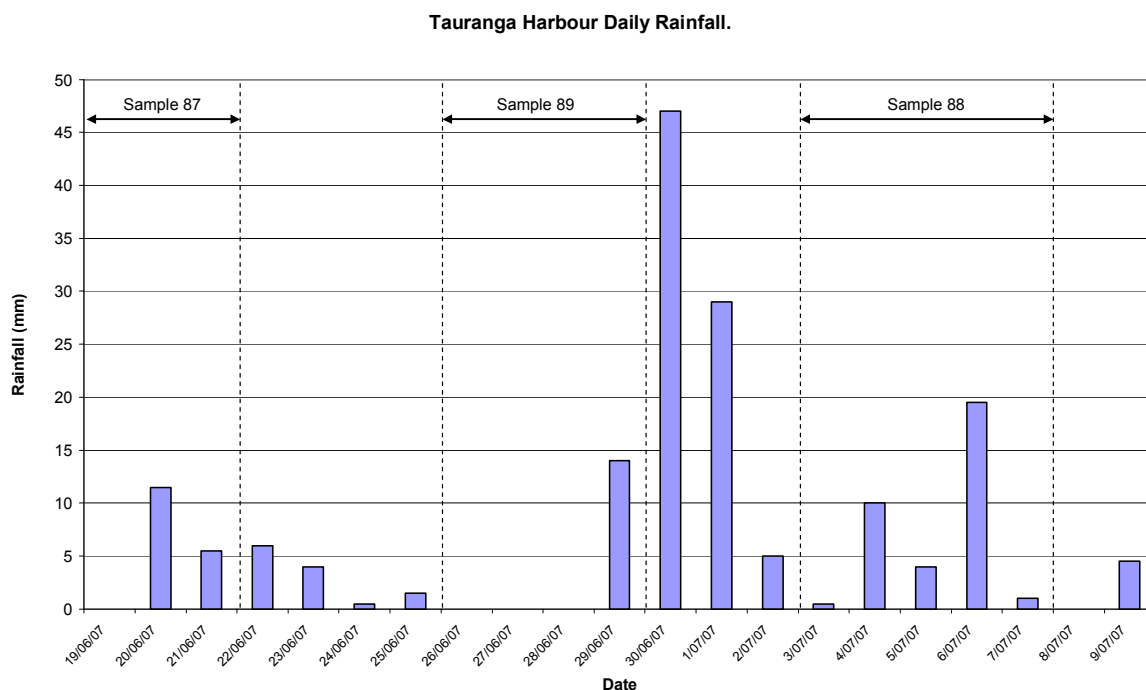

Figure 6.16 Rainfall recorded at Stannetts rain gauge, on the edge of the Tauranga Harbour

Wind data

The wind data showed that for Sample 87 and 89 there were significant periods of time when wind was coming from the south / southwest across the property at Pitau Road. For Sample 87 there was also a period (~15% of the time) where wind was blowing in from the sea. For Sample 88 there was a predominance of winds from the west and north-west for the sampling period. It should also be noted that winds from the easterly quarter impacted the site, and included wind speeds in the 20-30 kph band.

6.5.8 Conclusions

The stereo microscope analysis showed a presence of particles in the 20-60 μm size range. These however were not abundant. A staining of the filters was also present and this was caused by the <10 μm sized particles. A comparison with the earlier investigation imagery is complicated due to the collection mechanism differences. The earlier sample (24/4/07) would have been exaggerated due to the larger settling area and associated turbulence which promotes accumulation of nuisance dust.

Calculation of the concentration of TSP from each sample resulted in values ranging from 22 to 39 $\mu\text{g}/\text{m}^3$. The highest value recorded was for Sample 87. These concentrations are less than half of the recommended MfE trigger level (Table 6.8) for suspended particulate for sensitive receiving environments. A sensitive area typically has significant residential development.

Table 6.8 Dust trigger concentrations for different environments

Dust type	Trigger level
Deposited dust	4 g/m ² /30 days (above background concentration)
Total suspended particulate	80 µg/m ³ (24-hour average) – sensitive area 100 µg/m ³ (24-hour average) – moderate sensitivity 120 µg/m ³ (24-hour average) – insensitive area

The SEM analysis showed a range of dominant particles in each of the samples. These particles were predominantly from the finer fraction, and showed the elemental signature associated with marine and road dust sources. The larger particles (>10 µm) showed an elemental signature different from the coal storage shed sample. These larger particles do not have key elements that could define their source based on the SEM technique.

The SEM results from the three collected samples point to a typical urban dust profile for a residential development in a coastal environment setting. It should also be noted that key elements for industrial signatures were missing.

The wind data shows an increase in concentration when the wind is from the south westerly quarter. This would suggest the possibility of some material coming from the port area. No coal particles were determined from the samples but some general dust maybe originating from this port area (large sealed areas where timber etc is stockpiled, and heavy vehicle traffic is common).

Most of the particles in the sample were less than 100 µm. The presence of particles up to 100 microns in size indicates that this portion of the dust was most likely generated within 100 metres of the sample collection point, although greater travel distances are possible under high wind conditions. In addition, the smaller particles may be carried over greater distances.

In summary:

- No particles of coal were found in the collected samples.
- Total suspended particulate (TSP) concentrations for the collected sample are less than half the MfE nuisance dust level.
- Scanning electron microscope (SEM) analysis showed the collected samples consisted of particles of a marine and road dust origin.
- Wind data showed occasions during sampling where wind was coming from the port direction. Rainfall during sampling would have suppressed dust levels.
- Particle size information and transport distance data indicate the larger particles are from sources closer than the port. The finer fraction could be sourced from the port.

6.6 332 Maunganui Road, July 2007

6.6.1 Introduction

The following notes provide an assessment of the dust samples collected by Kelly Baxter from Maunganui Road, Mount Maunganui on 25 July 2007 (Figure 6.2). The complainant suspected the deposited material originated from the coal transfer facility to the south. The distance between the complainant's property and the coal load out silos is 500 m to the SSW. The aerial photography given in Figure 6.2 also shows the extent and proximity of the wharf facility.

This assessment is based on examination of the photomicrographs and SEM analysis of the collected samples.

6.6.2 Methodology

Five lifting tape samples were presented for analysis:

- C2007-1020/01 to C2007-1020/05 from the complainants south west facing back deck.

Each of these samples was viewed and photographed using optical microscopy and the sample from the floor of the deck was also examined using electron microscopy.

6.6.3 Meteorology

Wind data collected from the Totara St meteorological station was summarised for the seven days prior to the date of sampling (Figure 6.17). The wind rose shows a predominance of wind from the southerly sector (SE to SW).

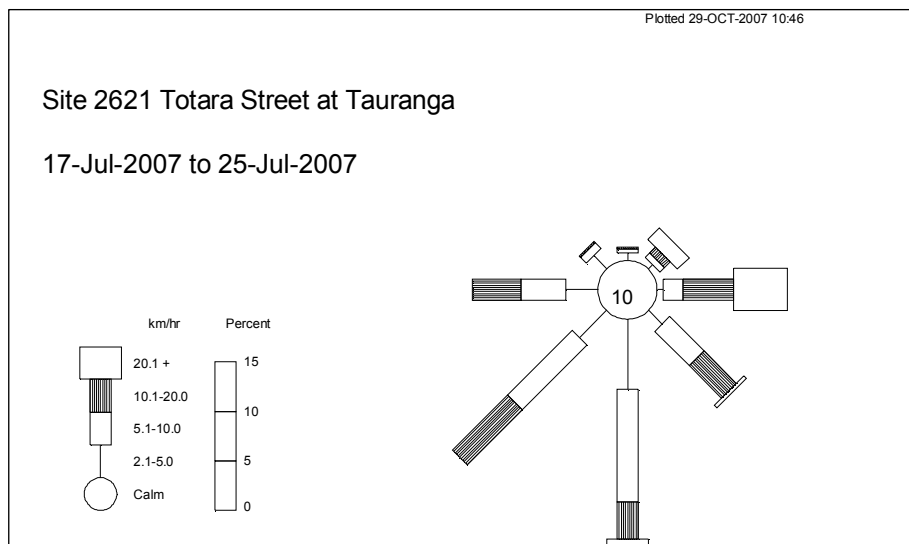

Figure 6.17 Wind rose for the seven days period prior to sampling

Rainfall is also recorded at a Tauranga Harbour rainfall station; 83 mm was recorded during the six days prior to sampling (Table 6.9).

Table 6.9 Recorded rainfall prior to sampling

Date	Rainfall (mm)
18/7/07	0
19/7/07	17
20/7/07	40
21/7/07	20
22/7/07	6
23/7/07	0
24/7/07	0

6.6.4 Results

Photomicrographs

To the naked eye all samples consisted of fine particles with a dark brown colouration.

Viewed through a microscope the particles in all five samples exhibited the same shape (typically angular) and colouration characteristics (Figure 6.18). The samples collected from the deck floor had a high percentage of larger particles (>100 µm) indicating a source of close proximity. The sample also contained easily recognisable larger fragments of woody material (greater than one millimetre).

All samples generally contained particles in the 20 to several hundred micron range. The settling velocity for particles of this size would allow for transportation by the wind which was experienced prior to the time of sampling.

The collected sample content looked similar to previous samples collected in the Mount Maunganui area. Clear crystalline fragments were present as expected in a coastal margin environment. Fibrous woody material was also evident. Light brown to dark brown/black angular particles were dominant which is typical of general dust in urban environments. There was also the presence of dark spherical particles which, due to their shape and dull sheen, are often classified as combustion by-products, these will be discussed further in the following SEM section.

Visually there were some characteristics similar to the particles identified in the sample collected earlier from the coal storage shed (Figure 6.19).

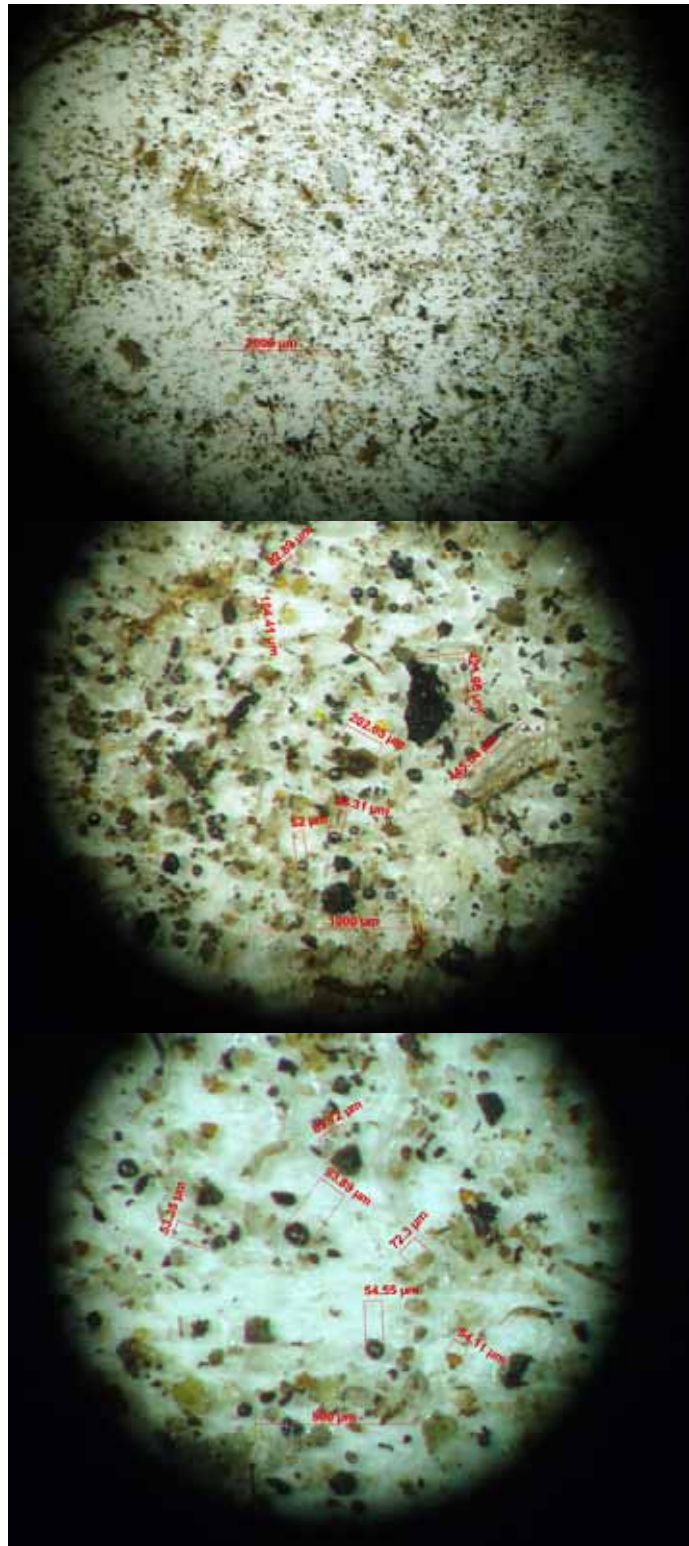

Figure 6.18 Photomicrographs of Sample C2007-1020/01 (1.2, 4.0 and 6.6 x magnification)

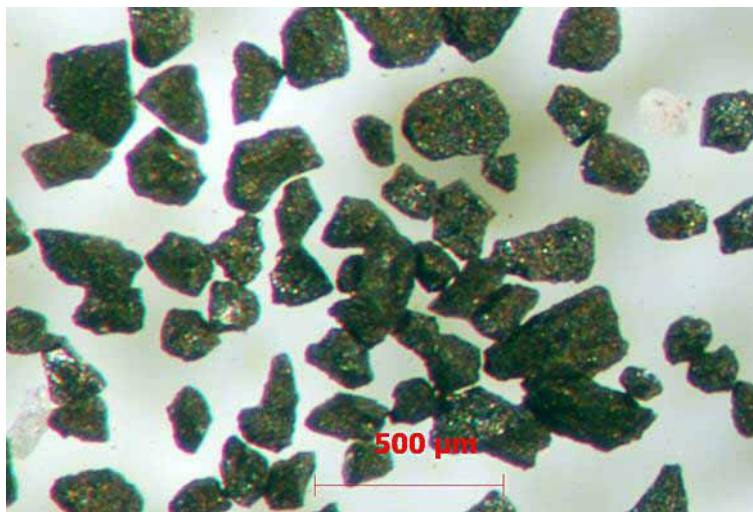
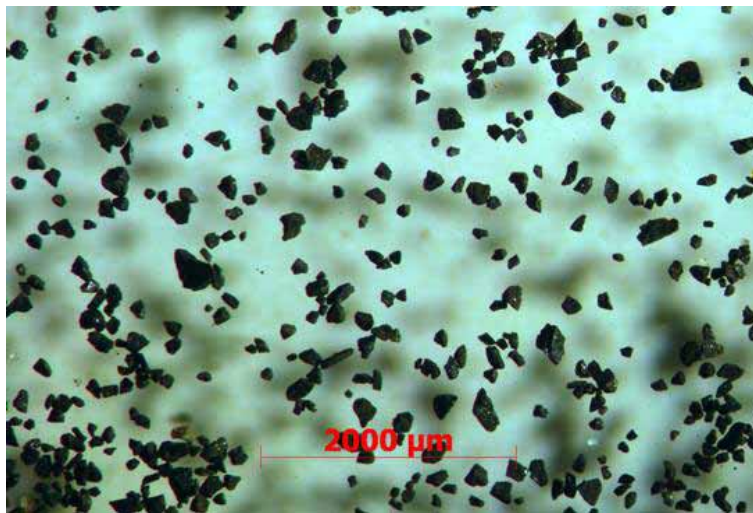

Figure 6.19 Photomicrographs of a sample from the coal storage facility (20 and 66 x magnification)

SEM

Due to similarity in visual characteristics shown between some particles in Figures 6.18 and 6.19, scanning electron microscope analysis was undertaken on the collected sample.

The coal storage shed sample results from an earlier analysis are shown in Figure 6.8. As expected a dominant carbon signature was evident (large peak closest to the y-axis). These characteristics were used as the standard for coal when comparing with the material collected on the sample from Tawa Street (Figure 6.18).

The sample was examined extensively with 20 individual particles investigated. Each investigation resulted in a series of images being captured and analyses determined. The images show typical particles (Figure 6.20), the spectra for which are also included.

It can be seen that a spectrum typical of the coal shed particles (in particular the key large carbon peak close to the y-axis) was not seen for any of the subsequent particles (Figure 6.20) which strongly suggests that coal dust was not present on the supplied sample collected from Tawa Street.

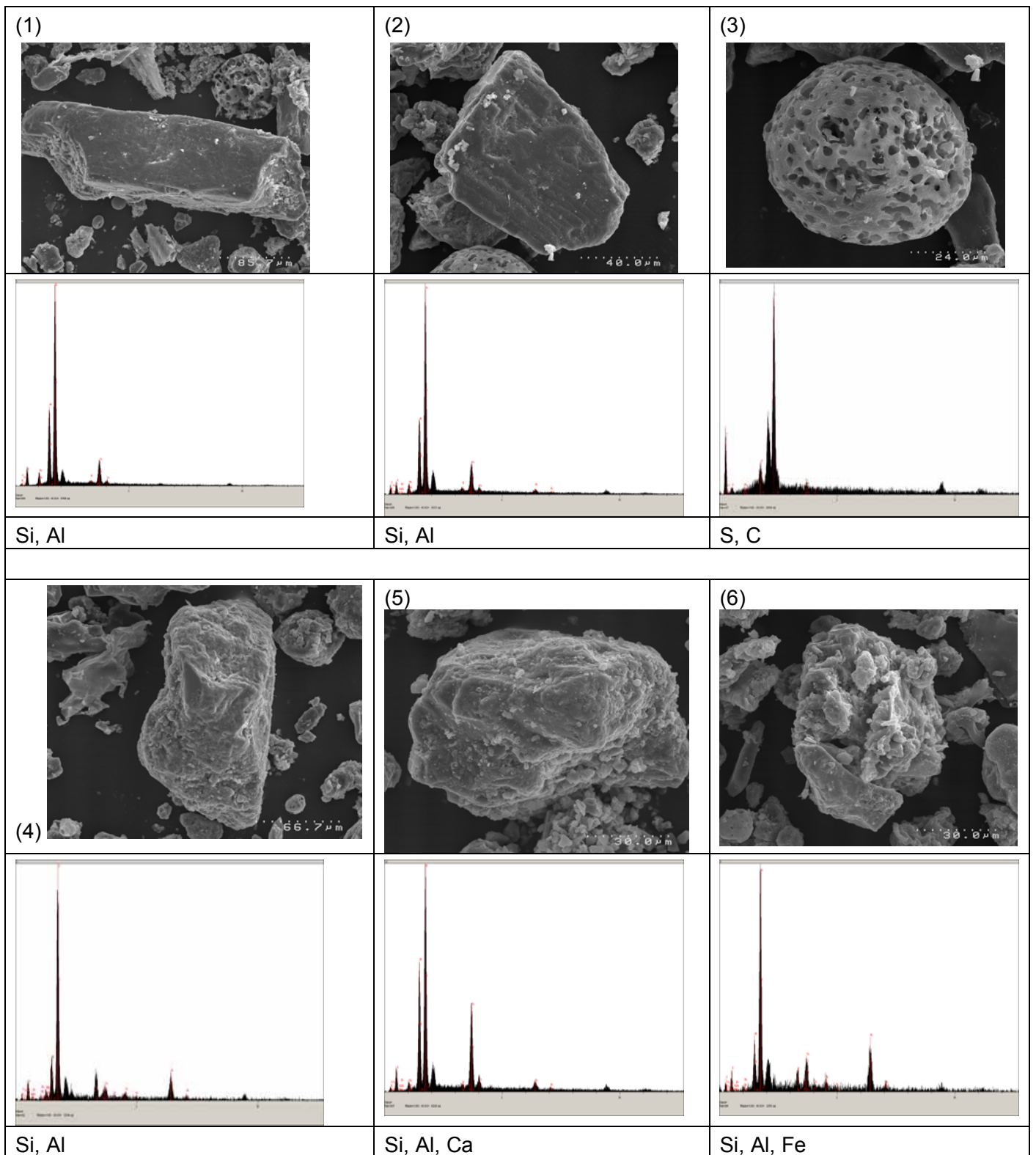

Figure 6.20 SEM images – Dominant particles with elemental signature and dominant elements listed in order of significance

6.6.5 Conclusion

The dominant elements that were identified by SEM for the collected sample are listed in Figure 6.20. Further identification of potential sources based on the spectra from representative particles for each sample can be partially achieved by using results from source apportionment investigations.

The elemental composition of the particles identified on the collected sample indicates a general urban dust profile with contributions from soil and road sources. Particle #3 is a combination of sulphur (S) and carbon (C) in composition suggesting a combustion process origin such as but not limited to ships, trains and motor vehicles. In international literature, particles of this type are referred to as cenospheres or char particles and have a spherical shape and a surface which is often covered with gas vent holes. The SEM technique for these types of samples allows for identification of dominant elements.

In summary:

- The photomicrographs showed some visual similarities between the collected sample and the coal storage shed sample, hence further analysis was required.
- Scanning electron microscope (SEM) analysis showed the collected samples were dominated by particles of a soil and road dust origin. This profile would be described as general urban dust.
- There was also the presence of cenospheres which have a sulphur and carbon signature as a result of their combustion origin.
- No particles of coal were found in the collected sample.
- Wind data showed that prior to the collection of the sample, the wind was predominantly coming from the direction of the Port and land to the south.
- Particle size information and transport distance data indicate that particles could also be sourced from the Port area.

6.7 Tawa Street, June 2007

6.7.1 Introduction

The following notes provide an assessment of the dust sample collected by Mike Caldwell from a residential property in Tawa Street, Mount Maunganui on 26 June 2007 (see Figure 6.2). The distance between the complainant's property and the Port area (due west) is ~170 m.

The complainant advised that he had encountered on numerous occasions dust which he believes to be coal dust settling over his dwelling/workplace.

The following assessment is based on my examination of the photomicrographs of the collected samples and results from SEM analysis.

6.7.2 Methodology

A lifting tape sample collected at the complainant's property was presented for analysis.

- C2007-1063/01 from the complainant's property.

6.7.3 Results

Meteorology

Wind speed and wind direction data shows that prior to the date of sample (Figure 6.21) collection (19 June to 26 June) there were generally moderate to strong winds from the southwest (Port area). These wind speeds would be sufficient to transport typical dust particles the ~170 m from the Port area to the complainant's property. No significant rainfall (4mm) was recorded during this period, which would aid dust suppression.

Site 2621 Totara St caravan at Tauranga

18-Jun-2007 to 26-Jun-2007

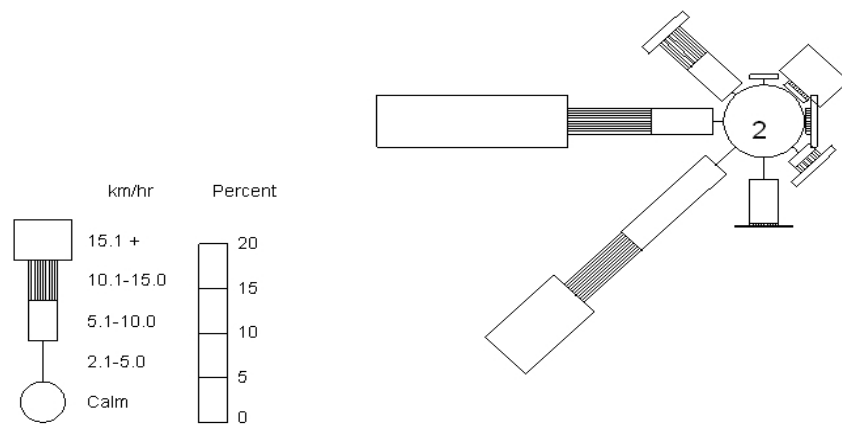

Figure 6.21 Wind rose for the seven day period prior to sampling

Photomicrographs

To the naked eye the sample consisted of fine particles with a light to dark grey coloration.

Viewed through the microscope the particles (Figure 6.22) had an irregular and often rounded profile with dark colouration. These had similar characteristics to the particles identified in the sample collected earlier from the coal storage shed (Figure 6.8).

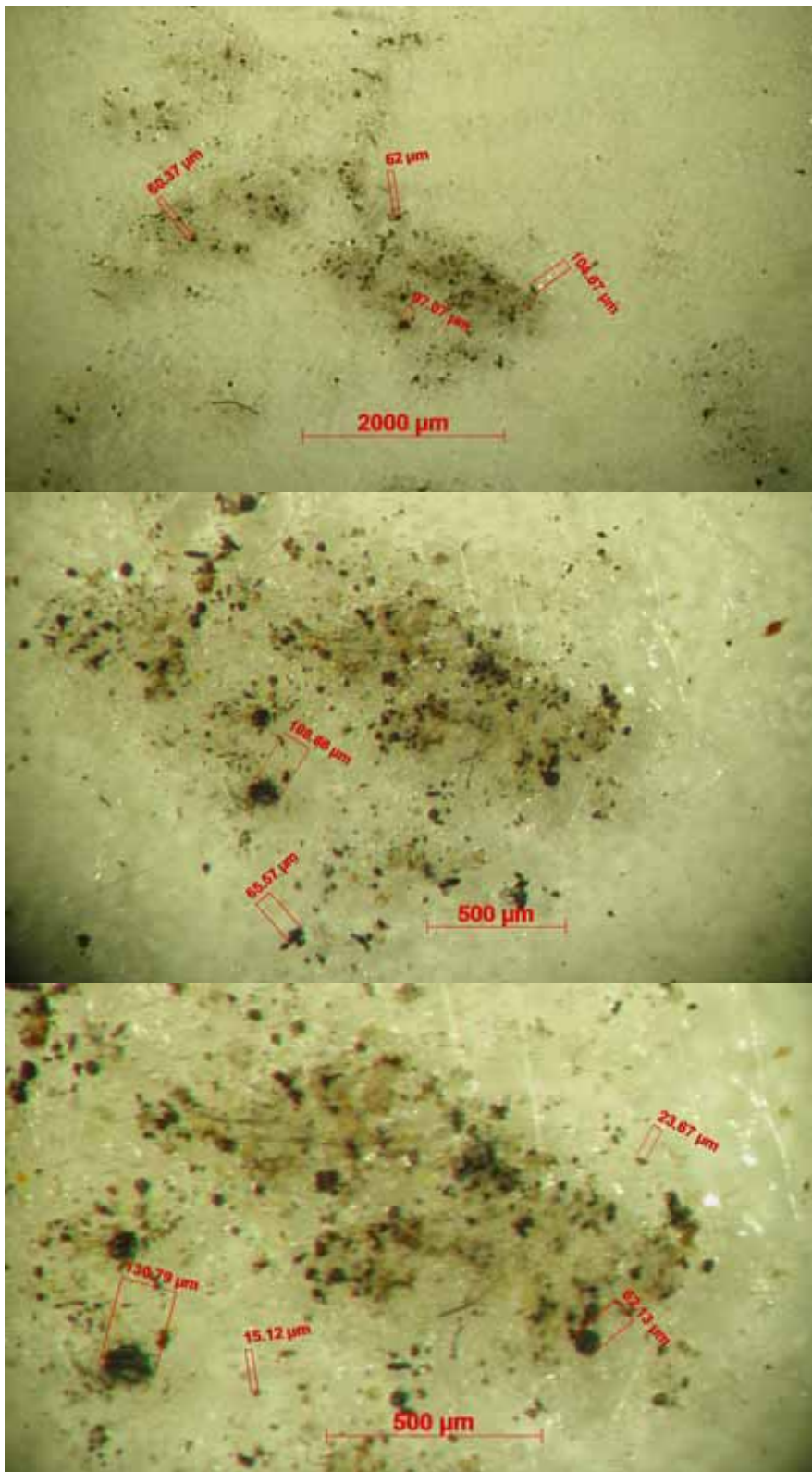

Figure 6.22 Photomicrographs of the collected sample (1.2, 3.2 and 5.0 x magnification)

SEM

Due to the similarity in visual characteristics shown in the photomicrographs (Figure 6.22), scanning electron microscope analysis was undertaken.

The collected sample was sent for analysis at the University of Waikato SEM facility.

Each sample was examined extensively and then a series of images and analyses were captured. The images show typical particles, the spectra for which are also included. It can be seen that a spectrum typical of the coal shed particles (in particular the key large carbon peak close to the y-axis) was not seen for any of the subsequent samples (Figure 6.23) which strongly suggested that coal dust was not present on the supplied sample from Tawa Street.

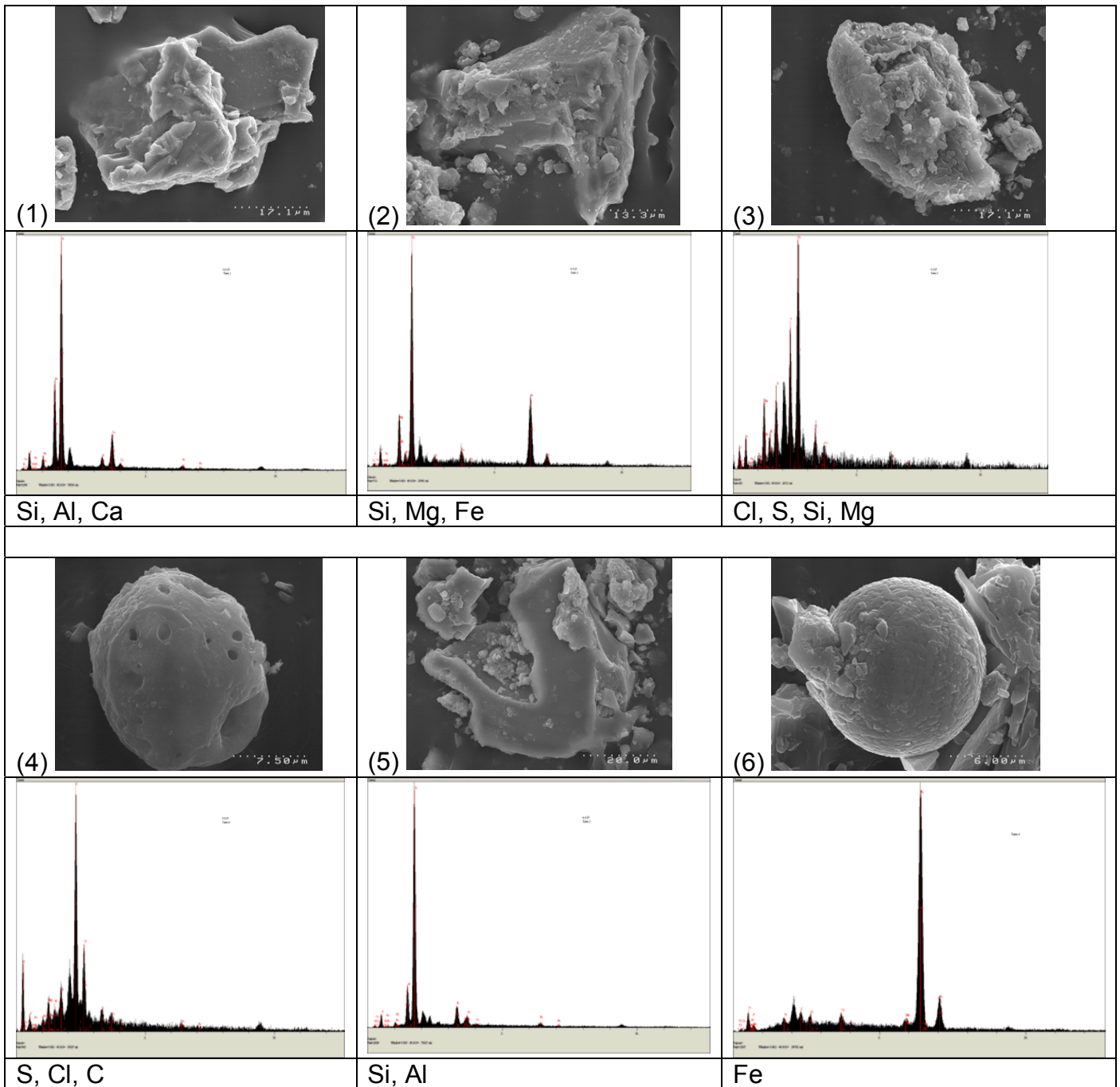

Figure 6.23 SEM images – Dominant particles with elemental signature and dominant elements listed in order of significance

6.7.4 Conclusion

The dominant elements that were identified by SEM for the collected sample are listed in Figure 6.23.

The elemental composition of the particles identified on the collected sample indicated a general urban dust profile with contributions from soil and road sources. Particle #6 was entirely iron (Fe) in composition, possibly suggesting the residue from welding activities.

This profile was similar to samples collected from other complainants' properties in the vicinity.

In summary:

- The photomicrographs showed similarities between the Tawa Street sample and the coal storage shed sample, hence further analysis was required.
- Scanning electron microscope (SEM) analysis showed the collected samples consisted of particles of a soil and road dust origin. This profile would be described as general urban dust.
- No particles of coal were found in the collected sample.
- Wind data showed that prior to the collection of the sample, the wind was predominantly coming from the direction of the port.
- Particle size information and transport distance data indicate that particles could also be sourced from the Port area.

6.8 Totara Street, June 2007

6.8.1 Introduction

The following notes provide an assessment of the dust samples collected by Mike Caldwell from several sites in Mount Maunganui on 26 June 2007 (see Figure 6.2). This assessment was based on examination of photomicrographs of the collected samples. The distance between the complainant's property and the three wharf sampling locations (due west) is 200-300 m. Aerial photography also shows a closer timber storage facility, 160 m to the southwest.

6.8.2 Methodology

Five lifting tape samples were presented for analysis:

- C2007-1133/01 and C2007-1133/02 from the complainant's property.
- C2007-1133/03, C2007-1133/04 and C2007-1133/05 from the neighbouring Port area.

Meteorology

Wind data collected from the Totara St meteorological station (600 m to the south of the complaints property) was summarised for the seven days prior to the date of sampling (Figure 6.24). From 21 June the wind direction was primarily from the south-westerly quarter with winds in a band from 6 to 40 kph (average 16 kph) during that time.

Site 2621 Totara St caravan at Tauranga

18-Jun-2007 to 26-Jun-2007

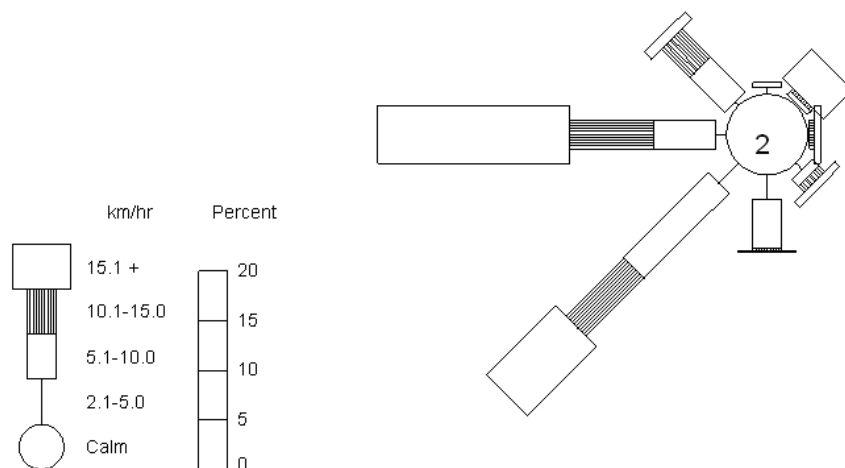

Figure 6.24 Wind rose for the seven day period prior to sampling

Rainfall is also recorded at the meteorological station; 4 mm was recorded on 21 June.

6.8.3 Results

To the naked eye all samples consisted of fine particles with a light brown coloration.

Viewed through a microscope the particles in all five samples exhibited the same shape (typically angular) and coloration characteristics (see Figures 6.25 and 6.26). The difference between the two sets of samples only related to particle size, in that the samples collected from the wharf area had a high percentage of larger particles. The wharf area samples also exhibited easily recognisable larger fragments of woody material (greater than several millimetres).

All samples generally contained particles in the 20 to several hundred micron range. The settling velocity for particles of this size would allow for transportation by the wind which was experienced prior to the time of sampling. This transportation process would also result in the aforementioned larger fragments being sorted and only the finer component being transported reasonable distances (several hundred metres) from the source.

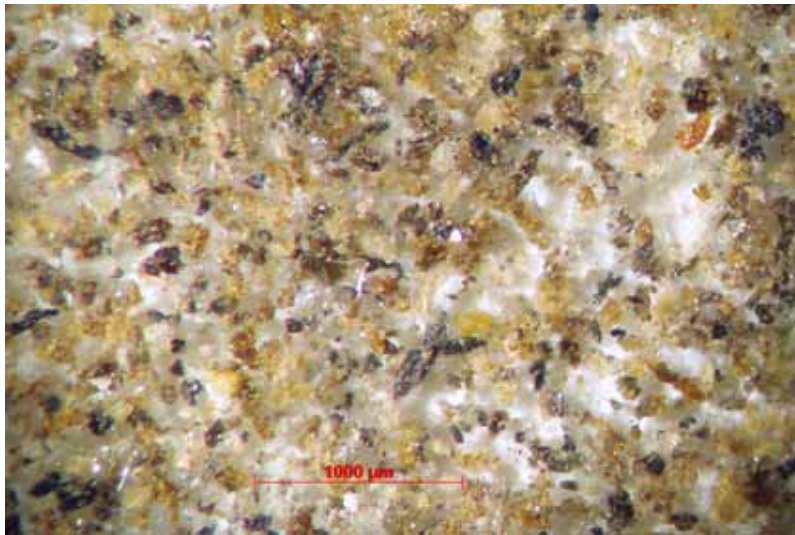

Figure 6.25 C2007-1133/01 (top) and C2007-1133/02 (bottom)

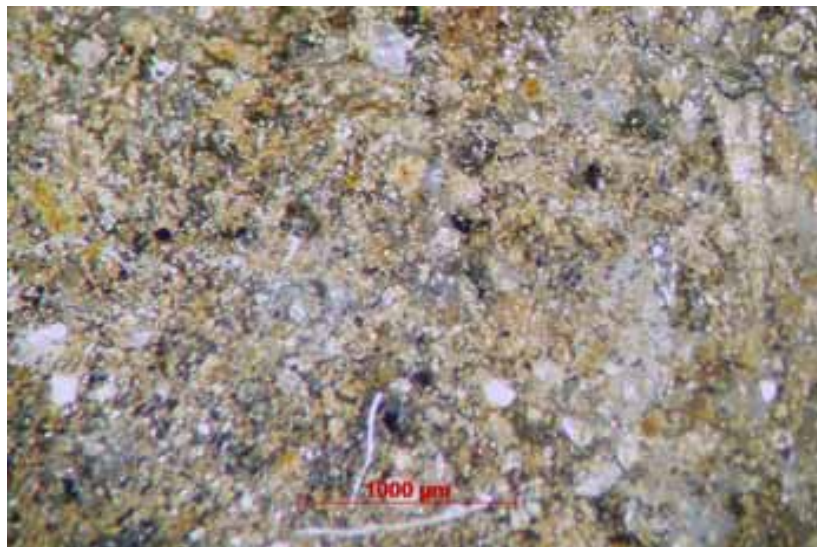
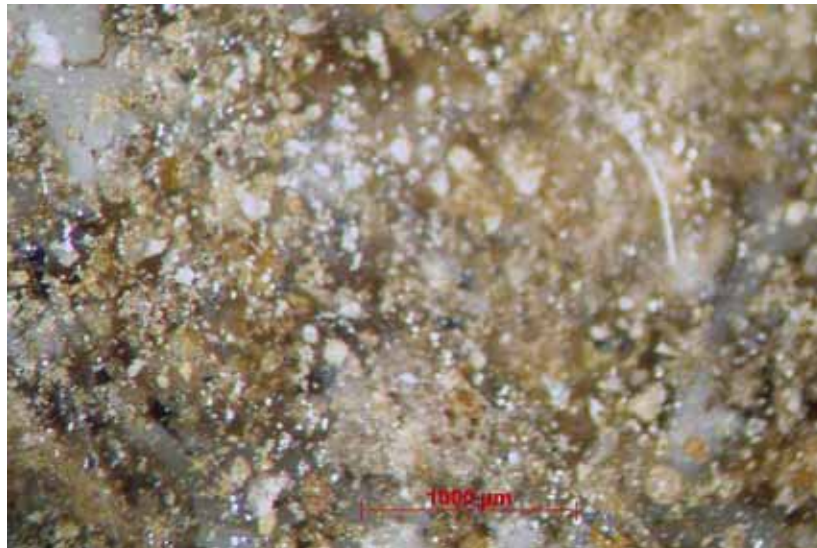
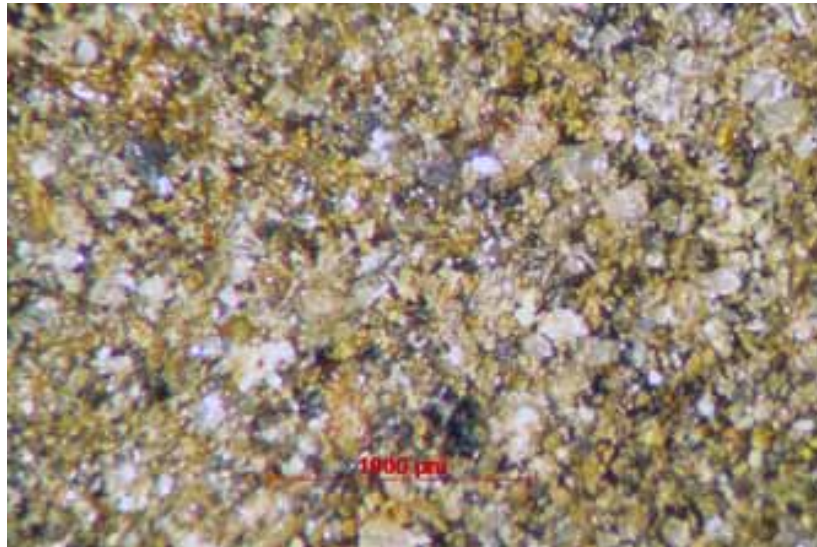

Figure 6.26 C2007-1133/03 (top), C2007-1133/04 (middle), C2007-1133/05 (bottom)

6.8.4 Conclusion

The physical and visual characteristics of the samples from the complainant's property (C2007-1133/01 and C2007-1133/02) were the same as those collected by Bay of Plenty Regional Council staff in the log storage area on the wharf (C2007-1133/03, C2007-1133/04 and C2007-1133/05).

6.9 Bruce Gardner samples, 2008

In May 2008 five samples were collected from the Mount Maunganui/Sulphur Point area by Bruce Gardner. These were a series of grab samples collected from the two marinas and from a property in May Street, Mount Maunganui.

Each sample was examined under the stereo microscope, and a selection of dominant particles and unique particles were then sent for further visual and elemental analysis using the SEM technique described earlier in this section.

The following is a summary of these results.

6.9.1 Tauranga Marina boat deck

Collected 23/5/08 15:30 from the deck of a vessel moored in the Tauranga Marina. This sample (Figure 6.27) was a mixture of particles from natural and anthropogenic sources. Row 1 shows a selection of cenospheres, which under the SEM have a typically circular appearance with a common surface appearance of a multitude of hollows which gives them a cavernous appearance. The hollows vary in number, size and distribution⁶⁰ (Figure 6.28).

The hollows are formed when gaseous or liquid material is expelled from the interior of the particle, due to an increase in internal pressure or to an external depression. Convection currents favour this process, which causes weakening in certain areas of the surface. These particles arise from combustion usually of fuel oil. They have a carbonaceous matrix and high sulphur content. Depending on their size they can contain characteristic trace metals⁶¹.

⁶⁰ Moldanova, J., 2009, *Characterisation of particulate matter and gaseous emissions from a large ship diesel engine*, Atmospheric Environment, Volume 43, Issue 16, 2632-2641.

⁶¹ Umbria, A. et. al., 2004, *Characterisation of atmospheric particles: analysis of particles in the Campo de Gibraltar*, Atmosfera, 2004, 191-206.

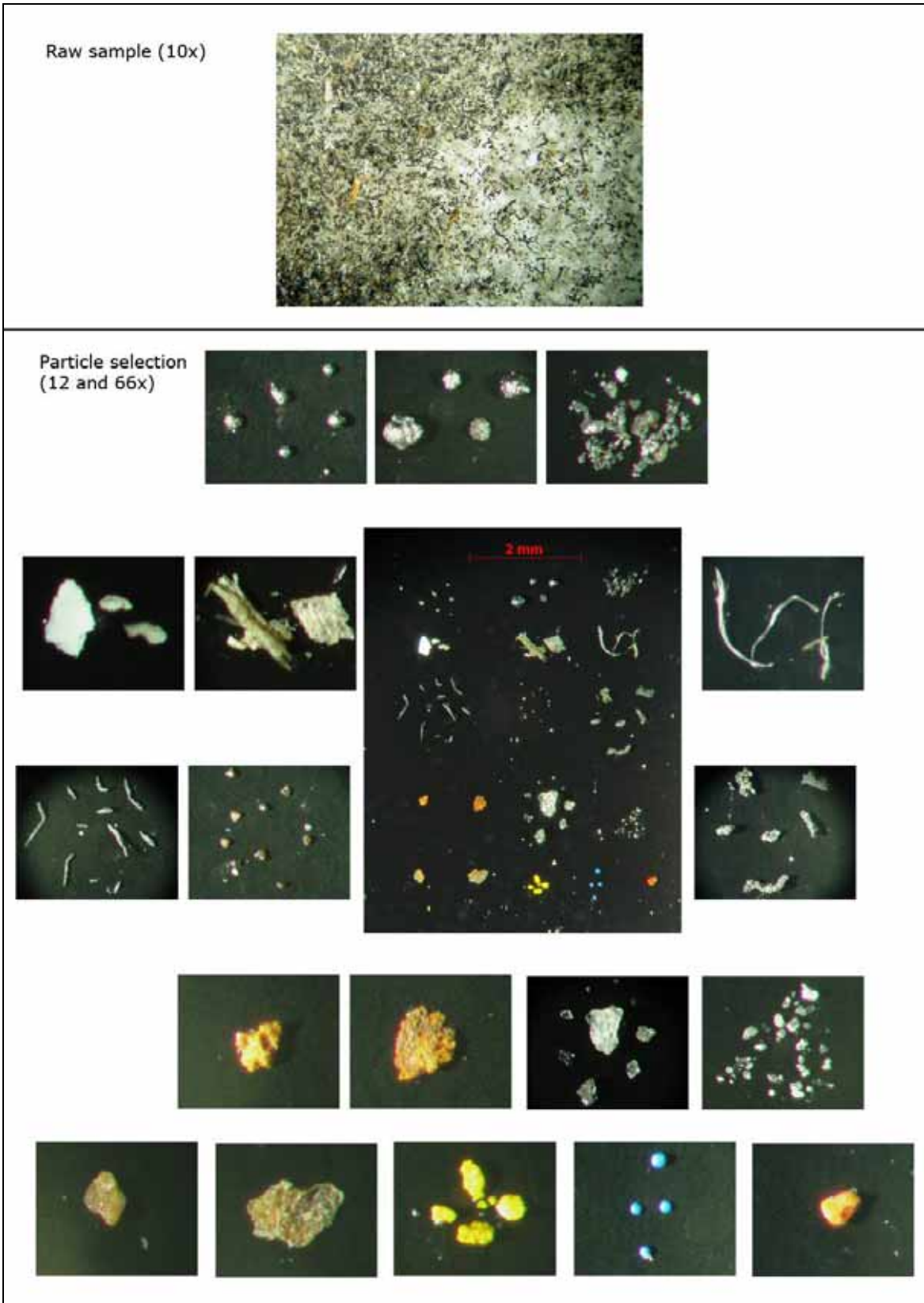
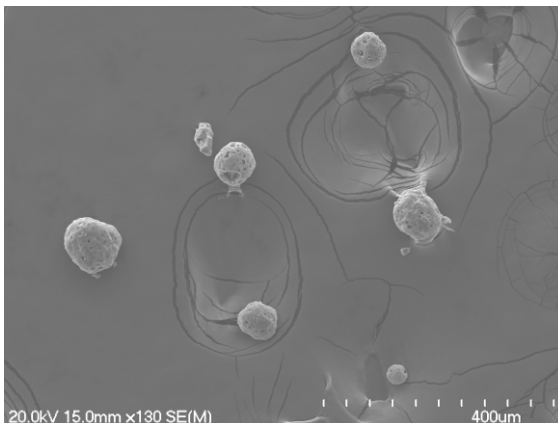

Figure 6.27 Selection of particles from Tauranga Marina boat deck sample, 23/5/08 15:30

SEM imagery of cenospheres



SEM spectra of cenospheres

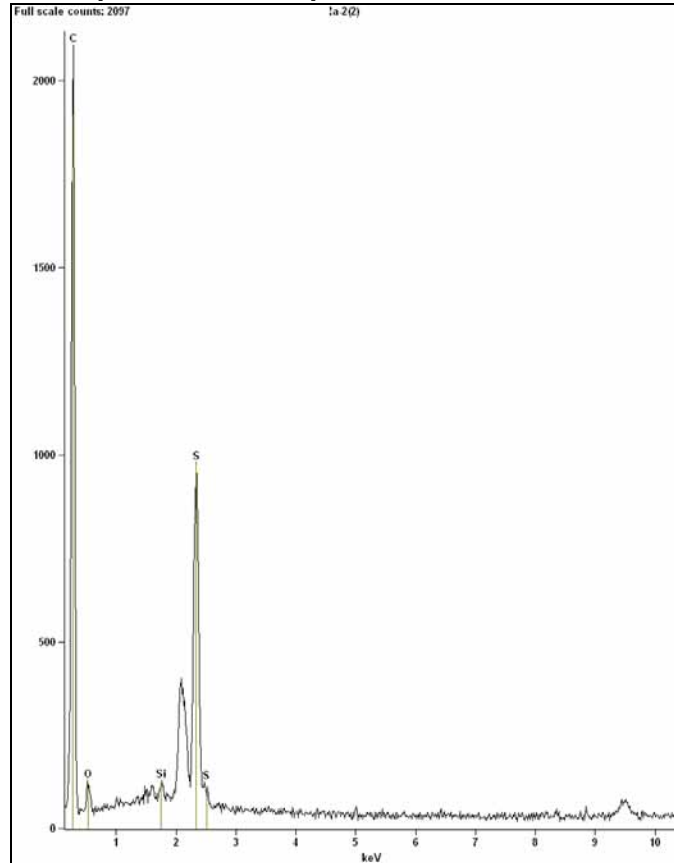

Figure 6.28 Cenospheres and associated elemental spectra

The first image in Row 2 shows particles with significant titanium signatures. The remaining two samples in this row are fibrous materials (high in carbon) and fibre strands, both of which are of a size that would prohibit single large wind borne transportation distances being achieved.

Row 3 (Figure 6.27) contains a mixture of natural and human derived particles. The first is the dominant particle in this sample. Visually these particles were dark grey to black in colouration. Physical manipulation of individual particles showed they had elastic properties and could be stressed without fracturing (Figure 6.30). The particles were elongated and normally tapered towards the ends. Sizes ranged from approximately 1 mm in length down to several hundred microns, and the elemental signature showed a dominant Si and Al composition. These particles are generally referred to as tyre wear particles and are a combination of tread and road surface material.

The second collection of particles contained fern spores⁶² (Figure 6.29). They were trilete, straight to concave-sided, and had an irregular spinulose structure. These characteristics fit them well to *Cyathea medullaris* (mamaku or black tree fern)⁶³. This spore was often seen in other presented grab samples. The obvious source of these spores would be the Kaimai Ranges, where prevailing west/southwest wind along with the added elevation would transport spores across the foothills and coastal plains. Small localised pockets on Matakana Island (Blue Gum Bay) may also provide small quantities along with a limited number of plants on Mount Maunganui itself^{64,65}. Transport into the area on logs may also be a possibility, but once again this would probably only be a minor source compared with that derived from the Kaimai Ranges native bush area.

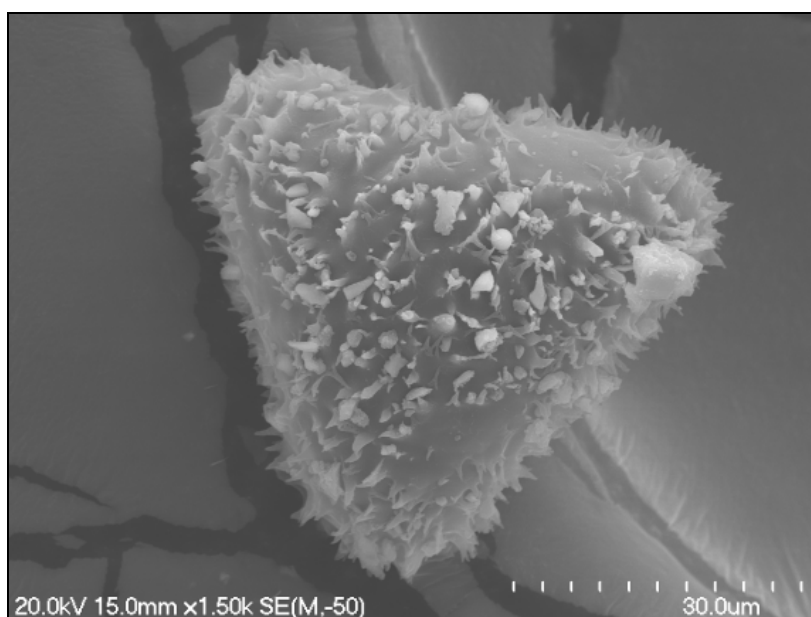

Figure 6.29 *Cyathea medullaris* spore.

The third selection of particles (in Row 3) had the same properties as the earlier tyre wear particles apart from form. These were larger and more angular in appearance, and the elemental signature was similar, albeit with a higher carbon percentage.

⁶² Large, M.F. and Braggins, J.E., 1991, *Spore atlas of New Zealand ferns & fern allies*. Supplement to the New Zealand Journal of Botany 1991.167 p.

⁶³ Pers.coms.: Dr Ian Raine, Biostratigraphy Team Leader, Paleontology & Environmental Change Section, GNS Science.

⁶⁴ Pers. coms.: Nancy Willems, Environmental Scientist, Environment Bay of Plenty & Walter Stahl, Pest Plant Officer, Environment Bay of Plenty.

⁶⁵ Wildland Consultants Ltd, 2008, *Natural Areas in Tauranga Ecological District.*, Contract Report No. 1914 Prepared for Environment Bay of Plenty, Whakatāne.

SEM imagery of tyre wear particles.

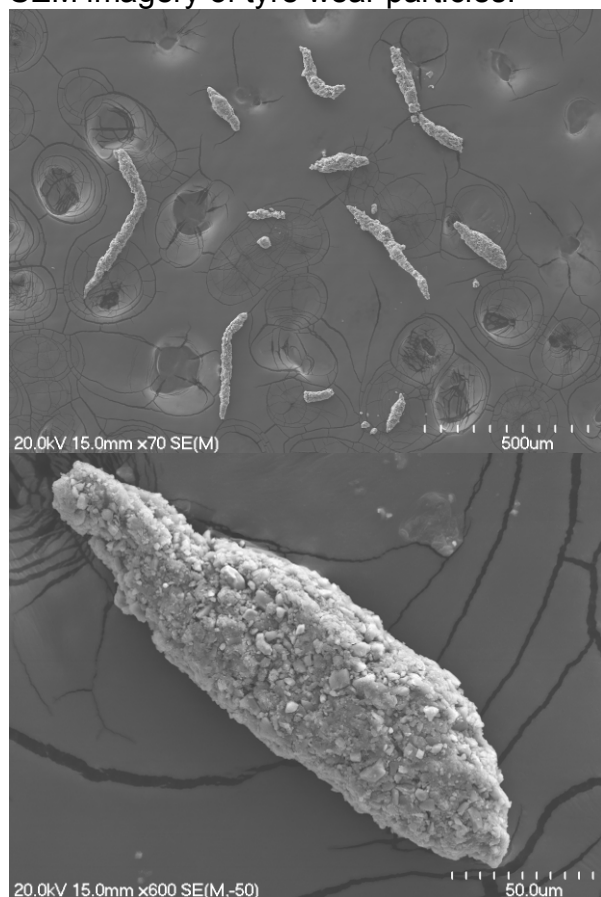

SEM spectra of tyre wear particles.

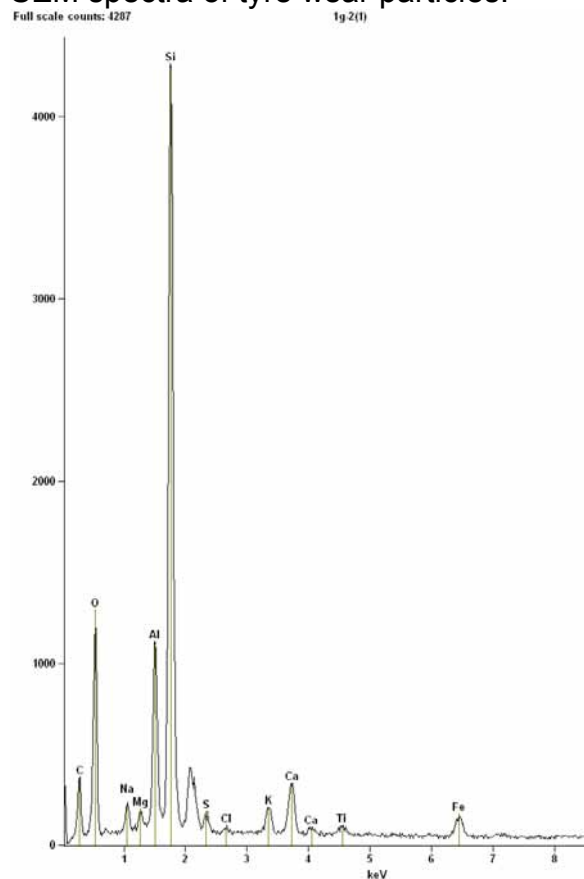

Figure 6.30 Tyre wear particles with elemental spectra

The first two particles in Row 4 (Figure 6.27) contained high proportions of iron and were identified as rust scale. The third group of samples was a selection of quartz crystals with a transparent crystalline appearance dominant in silica. The remaining sample in Row 4 was a grab sample of common fragments with an elemental profile typical of soil particles.

Row 5 (Figure 6.27), particles one and two also had this typical soil profile but were larger and more variable in colouration. The size of these particles would limit the airborne transportable range, hence suggesting a close by bare ground source. The remaining three samples were visually striking due to their colouration and morphology, all three are either examples of paint globules (blue particle) or paint fragments. All had a common suite of elements that appear in the SEM analysis with chromium, lead and titanium being dominant.

In summary the sample was dominated by the tyre wear particles (Figure 6.30), giving it the generally dark coloration and this component was supported by other dark particles associated with shipping emissions (cenospheres) and typical soil particle contributions. Paint particles were also detected and are not out of sorts with this marina environment where routine maintenance activities are undertaken.

An independent interpretation of samples collected from the Tauranga Marina has been performed by Graham Environmental Consulting Ltd, and the report for this work is shown in Appendix 6.

6.9.2 36C May Street, Mount Maunganui

This sample was deposited over approximately two months (March – April 2008) at a residential property in May Street (Figure 6.34).

In Figure 6.34, Row 1, particle one shows the agglomerated nature of portions of this sample (Figure 6.31). These clumpings were typically greater than a millimetre in size and a heterogeneous combination of individual particles down to sub-micron size. The triangular pollens were also present along with a variety of sizes of cenospheres. The smaller fragments had a dominant Si/Al elemental profile indicating a possible general soil composition. Particles two and three were weathered and abraded quartz crystals.

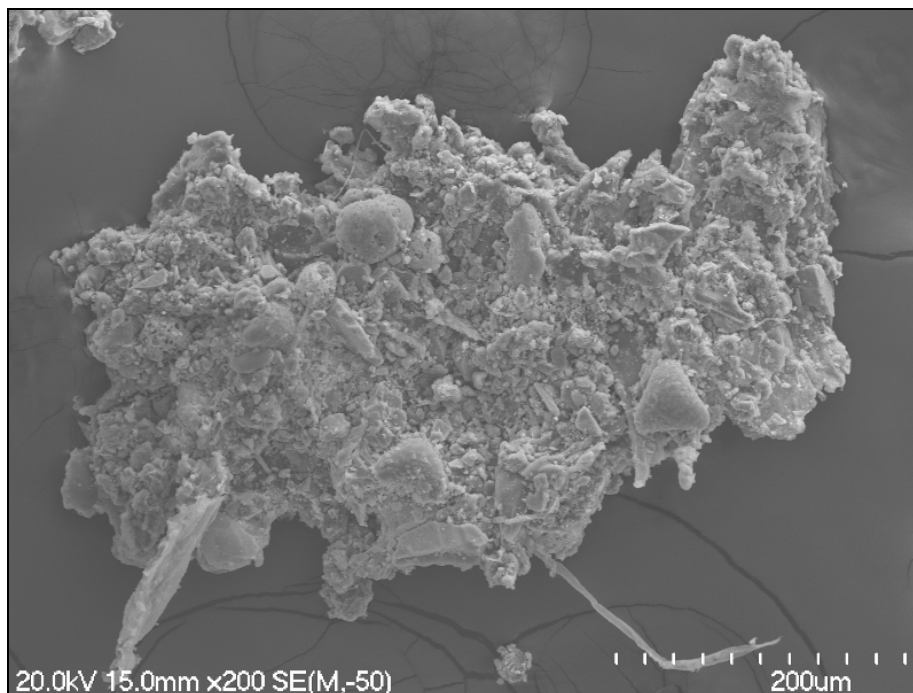

Figure 6.31 Agglomerated nature of particle clumpings in this sample

Row 2 contains particles which were also found in earlier grab samples. Tyre wear and cenospheres are common in this May Street sample.

The first two particles in Row 3 contained no unique or definitive elemental properties, although the second had the presence of sulphur suggesting a possible combustion origin. The first particle had a striking fibrous appearance, possibly suggesting a woody origin. The third selection of particles were the triangular pollen grains which were also evident in the earlier discussed sample (see Section 6.9.1).

Row 4 shows a mixture of human derived and natural particles. The first particle had an elemental signature common to a combustion by-product. Although not spherical in morphology a presence of sulphur once again points to this, along with the finely pitted surface texture. The second particle was a paint particle with a dominant Pb and Cr composition. The third particle was an agglomeration of pollen (Figure 6.23), this grouping could be the result of natural tackiness of these individual grains, and could be the “glue” responsible for the formation of particle one in Row 1. Finally there were four small spherical particles to the right of the final pollen particle which are not apparent in the photomicrograph. These measured approximately 50 microns in diameter and had a dominant Si profile with smaller proportions of Ca and Na (Figure 6.33).

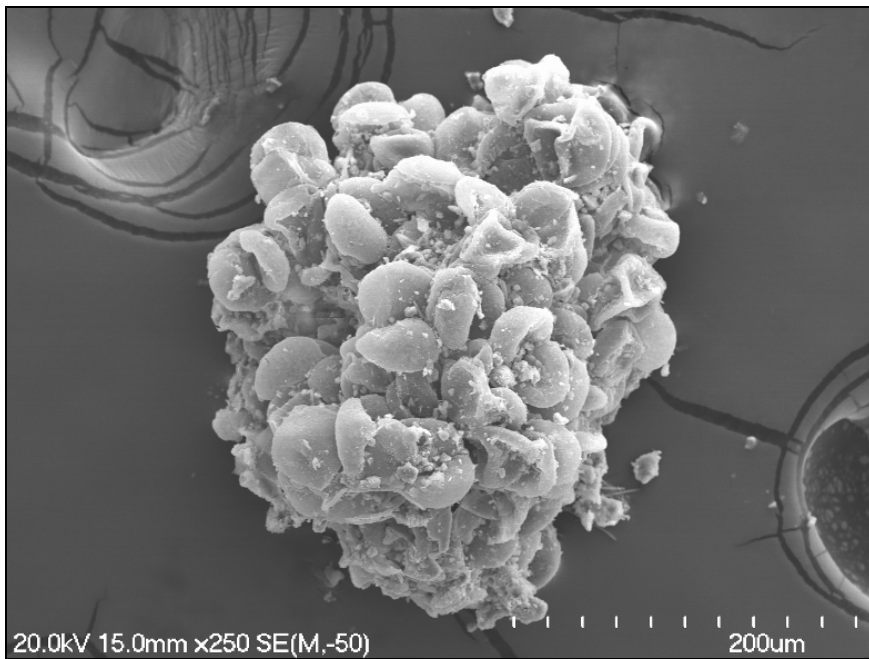

Figure 6.32 A grouping of pollen

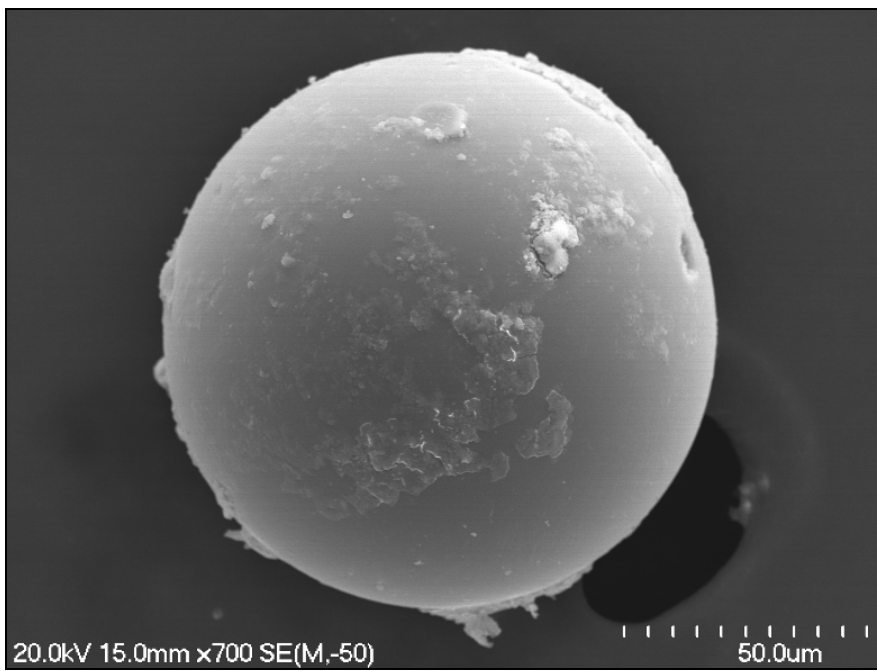

Figure 6.33 The perfect form of spray paint particles

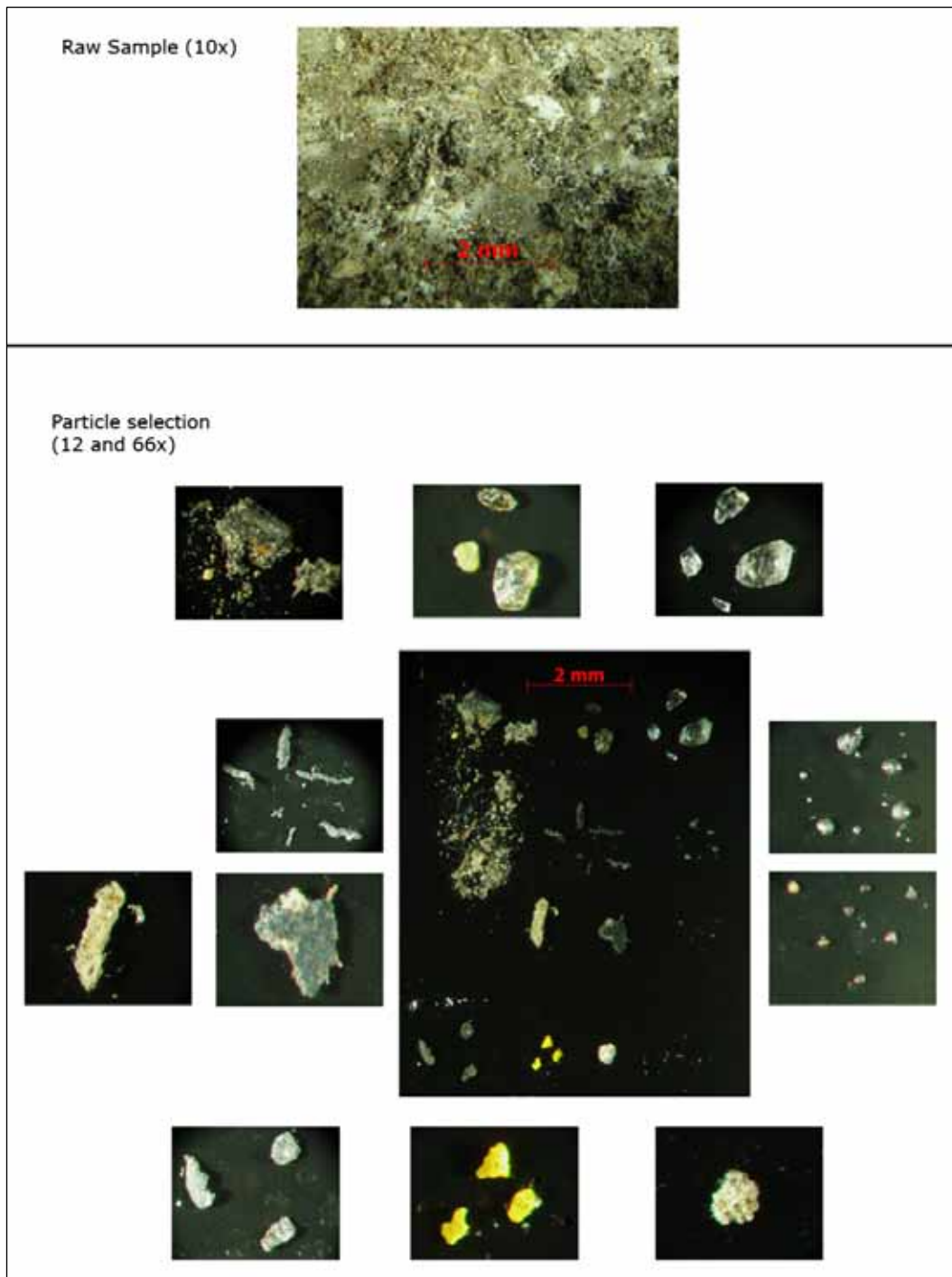
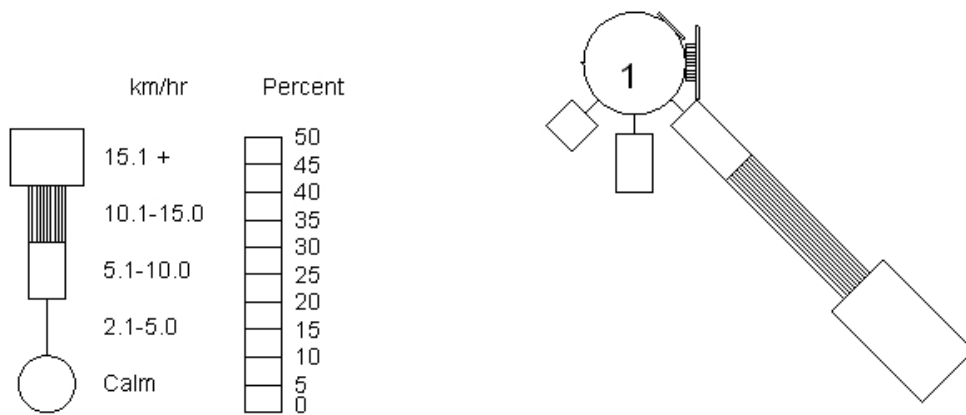

Figure 6.34 Selection of particles from 36C May Street, Mount Maunganui collected over approximately during March – April 2008

6.9.3 Tauranga Harbour Bridge Marina restaurant table

This sample was collected from a table at the Harbour Bridge Marina restaurant on 26/5/08. The table was reportedly cleaned 24 hours earlier. Wind data for the preceding day is shown in Figure 6.35. Based on this wind information the upwind areas are primarily the carpark, Te Awanui Drive and the area being developed for the new bridge eastern approach.



Aerial photographs showing pre (left) and post (right) bridge approach development Te Awanui Drive with the Tauranga Bridge Marina and surrounds.

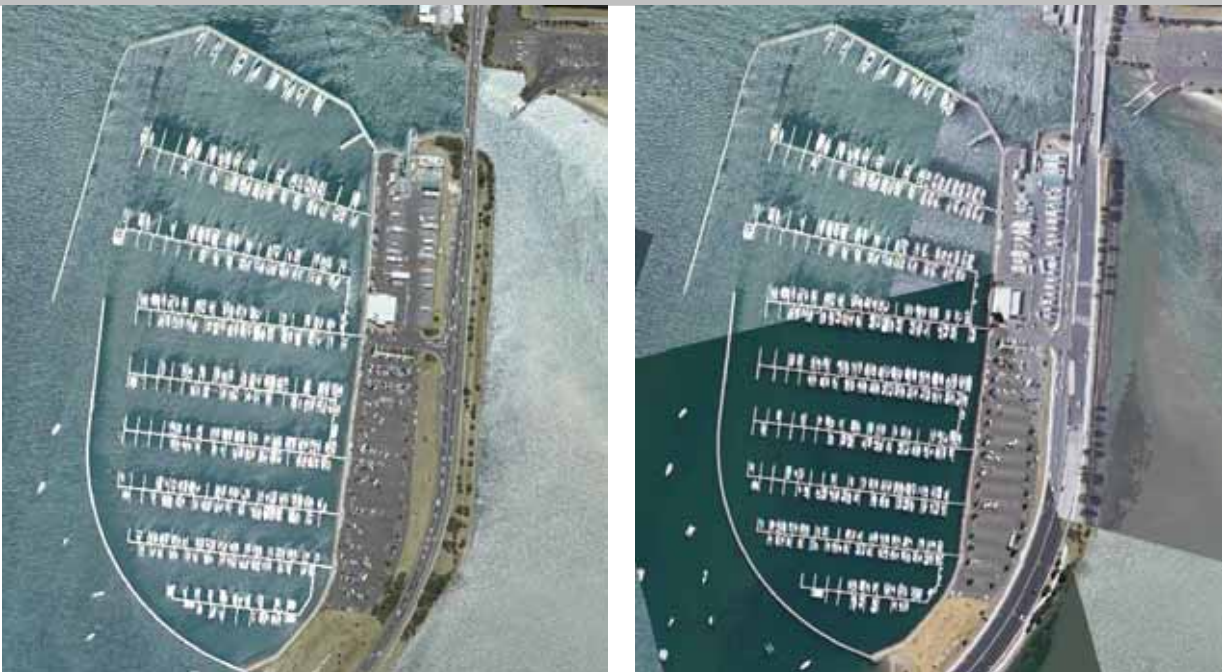

Figure 6.35 Wind rose and aerial view of area of interest

To the naked eye the sample (Figure 6.36) was similar to the sample collected at the May Street property; a heterogeneous tacky collection of particles ranging in size from nearly several millimetres down to sub-micron.

Row 1, particles one and two (Figure 6.36) were a grab from the raw sample, as described above, it was not uniform in any way and had the presence of cubic salt crystals which would be common in this environment. Particle three was the ever present tyre wear particles which in combination with the soil particle gave this overall sample its dark brown caramel colouration. Many fibrous strands (Row 2) were present, and seemed to add to the adhesive mass of material in this sample. The bottom two particles were the visual and elemental outliers with paint fragments (yellow) again present with a strong Pb and Cr signature. The larger of the two was a wood fibre fragment.

The remaining selected particles from this sample all showed signs of weathering and abrasion with few angular profiles present. Colouration varied with grey and cream particles being the more abundant. Quartz crystals were common. All of these particles however had the unremarkable Si and Al signature pointing to a general soil origin.

In summary the particles within this sample were representative of a general exposed soil/adjacent to a busy roadway type of environment.

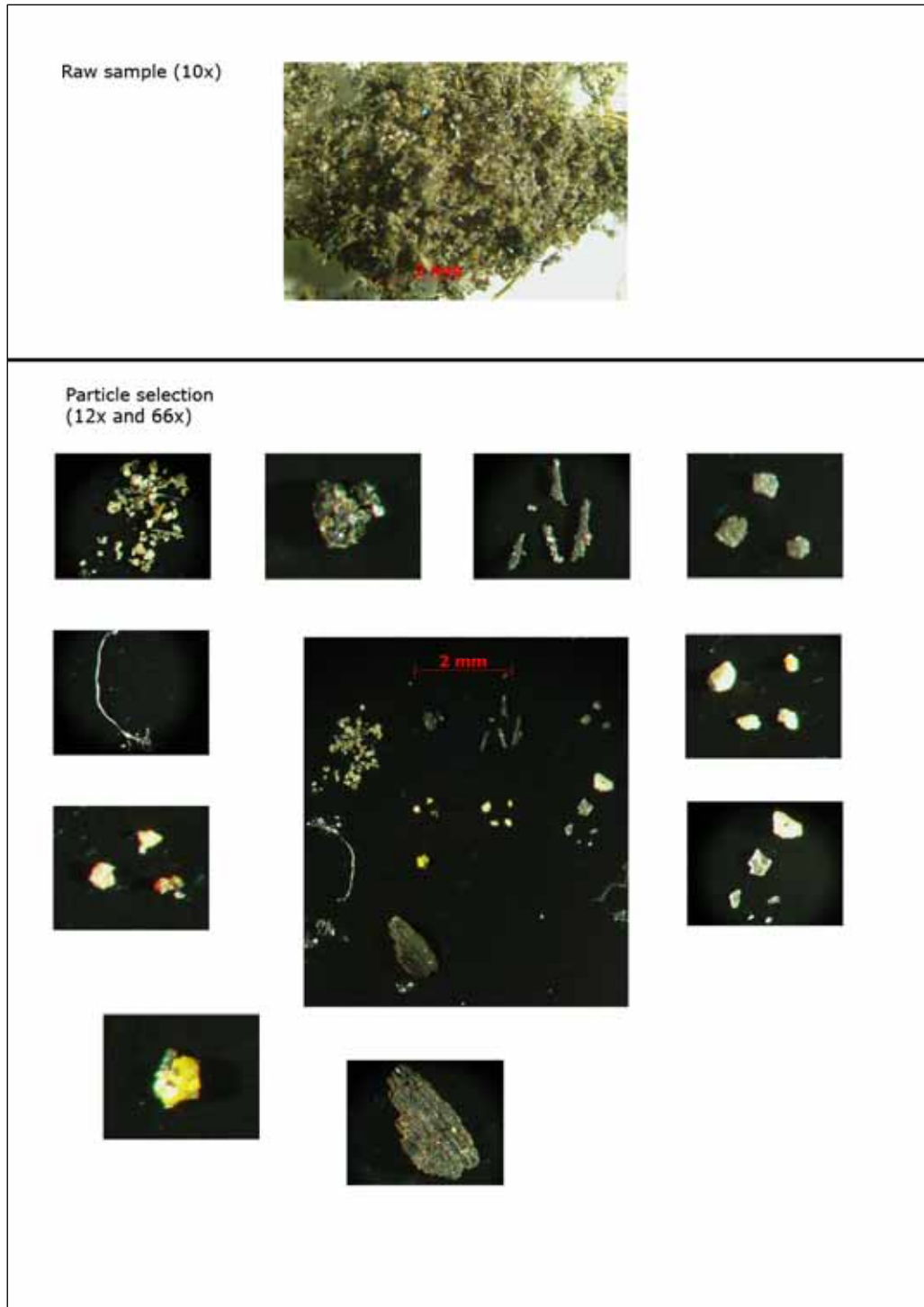

Figure 6.36 Selection of particles from restaurant table at Tauranga Harbour Bridge Marina. Table cleared 24hrs previously 26/5/08 15:00

6.9.4 May Street, Mount Maunganui

This sample was collected from an outdoor table (25/5/08) which had been washed seven days earlier (Figure 6.38).

The wind information shows a dominant south-easterly component during the period of deposition.

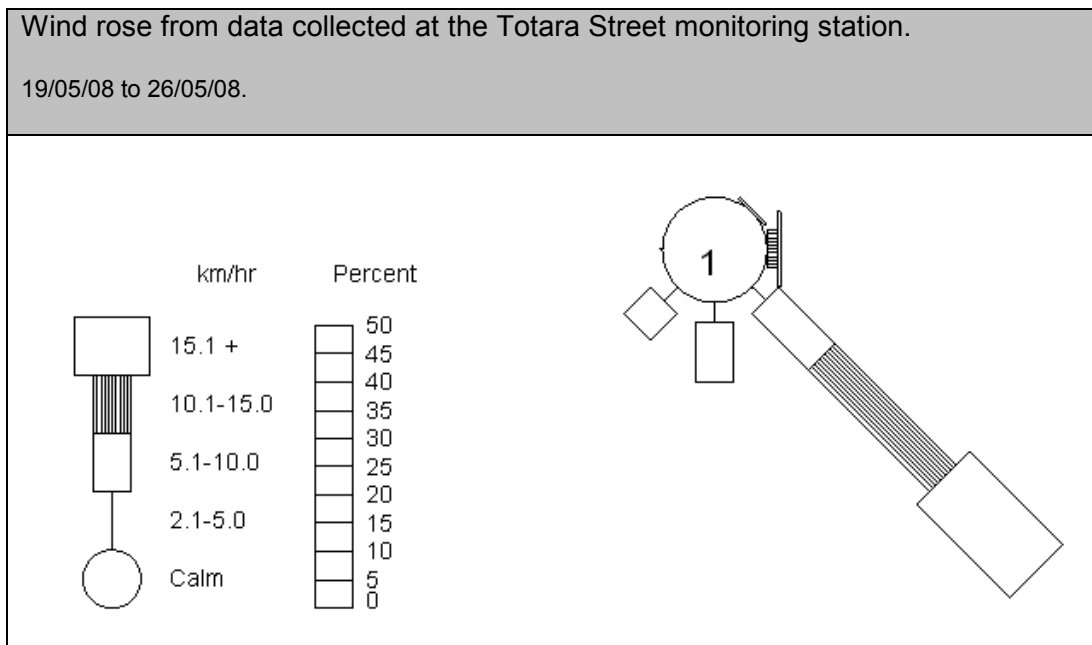

Figure 6.37 Wind rose for period of interest

Individual particles were clearly identifiable to the naked eye for this dark grey sample. Lighter larger particles were present (Row 1, sample one) but these made up only a minor contribution to the entirety of the sample. The majority of the particles are represented by the remaining two samples in Row 1 and the first sample in Row 2. The former were associated with combustion processes with char particles rich in carbon and cenospheres present. The other major contribution was from the tyre wear particles which have also been dominant in the previous samples (see section 6.9.1 and 6.9.2).

Fibrous woody fragments were also present, although not dominant, along with several pieces of yarn (Row 3). A few globules of paint were also retrieved from the raw sample along with a reasonable number of weathered quartz crystals (of a uniform size ~50 microns).

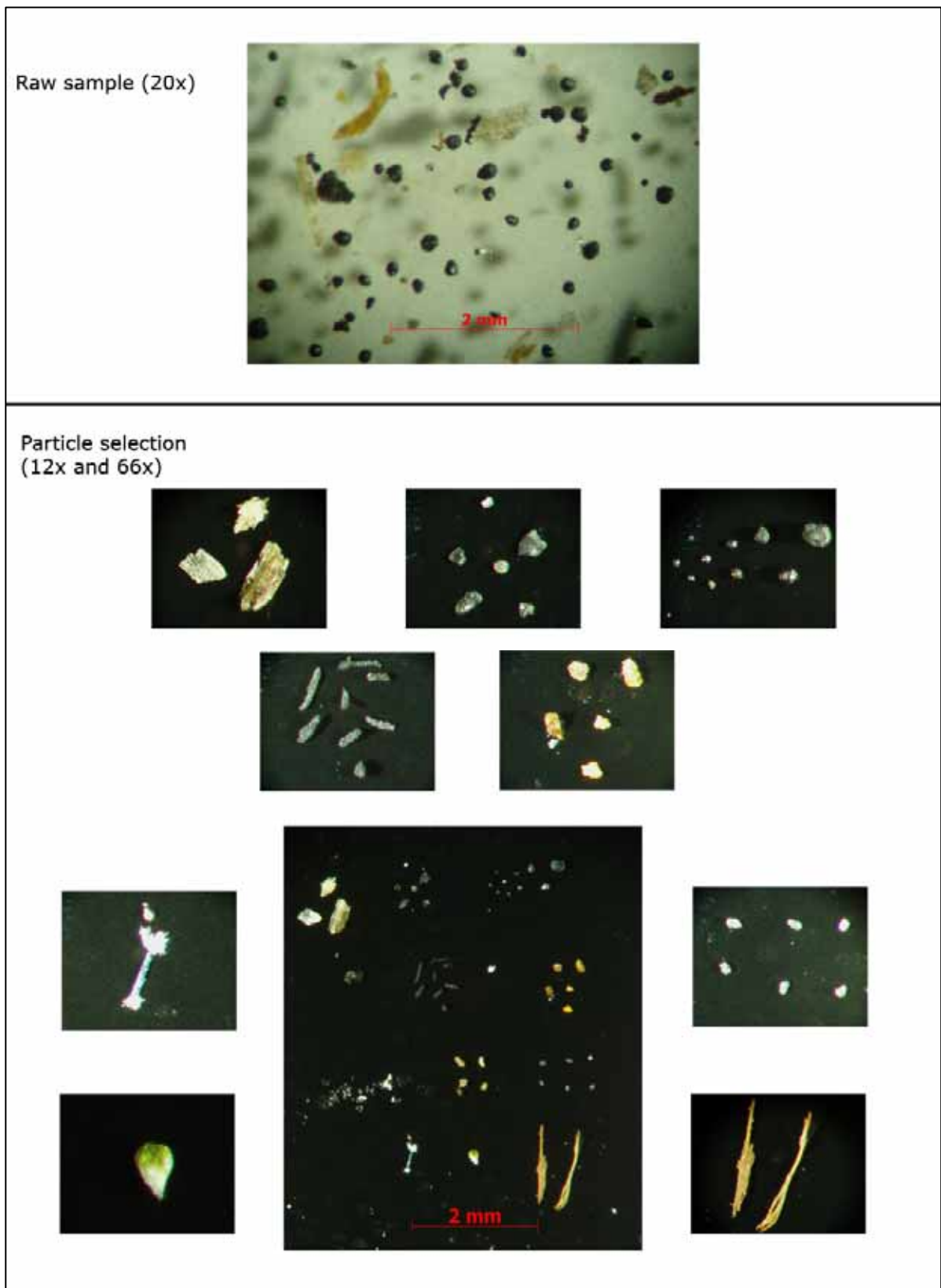

Figure 6.38 Selection of particles from 36C May Street, Mount Maunganui, outdoor table cleaned on 18/5/08

6.9.5 Harbour Bridge Marina boat deck, 2008.

This sample was collected on 27/2/08 from a vessel moored in the Tauranga Bridge marina (Figure 6.40). The initial visual examination revealed a heterogeneous sample of overall light brown appearance. A small portion of the particles showed an attraction to magnetism. A wide variety of particle morphology was present with the larger particles being in the several hundred micron size range although the sample could be described as being reasonably well sorted⁶⁶ in relation to particle size.

Row 1, particle one and Row 2, particle three showed the same elemental composition pointing towards road dust particles rich in Si and Al. Quartz particles were once again present in large numbers and are shown in Row 1 particle two. The commonly appearing tyre wear particles were also abundant (Row 1, sample three). Row 1, particle four shows a common grouping of smaller particles many of which had a sole Fe composition. Some were globular suggesting a welding origin, while others could have been from general metal working operations.

Row 2, particle one shows fragments of a Ca mineral. Sample two was a different version of the road dust/urban dust particles with C, Si and Al present. Row 2, particle four, was a new type of spherical particle (Figure 6.39). These had a similar visual appearance under the optical microscope, but showed a different surface characteristic at the greater magnifications achieved with the SEM. The common gas vent holes associated with other cenospheres has been well documented in this report, however these particles lacked this property, although the early signs of deformation could be partially seen on the surface (Figure 6.39). The elemental signature was quite different, the traditional cenospheres are rich in only C and S. The cenospheres in this sample had a suite of elements associated – Si, C, Zn, Cu, Cl, Mg in decreasing order of “counts”. Their morphology and elemental composition suggested a combustion origin, while the absence of sulphur indicated a relatively ‘clean’ fuel, such as diesel or light fuel oil.

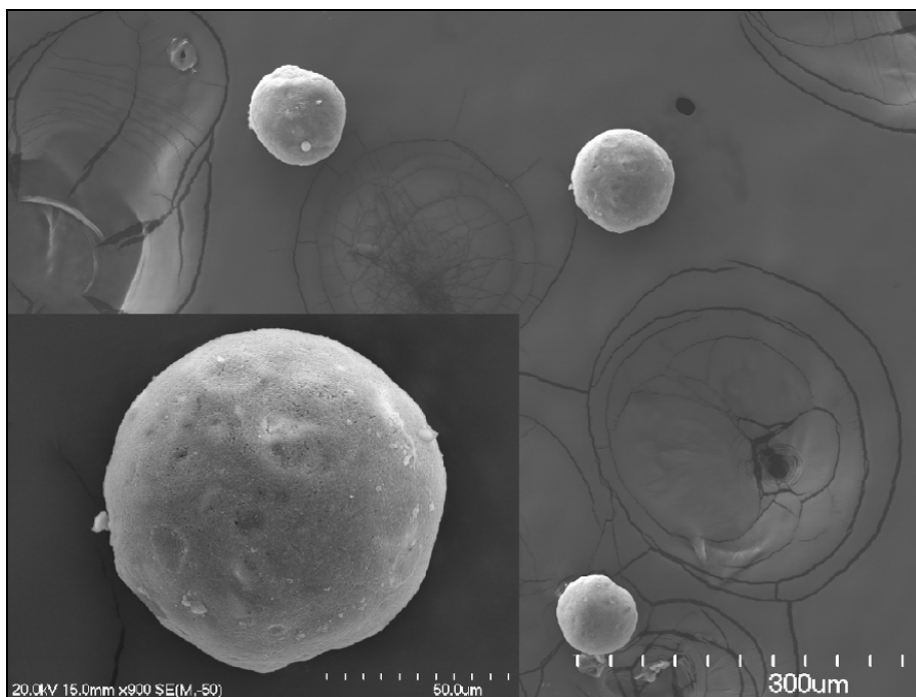
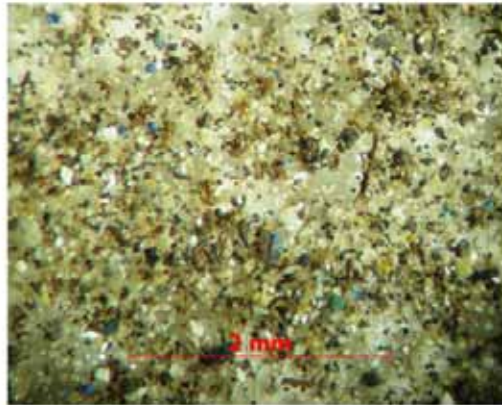

Figure 6.39 Cenospheres from the collected sample

⁶⁶ Sorting indicates the distribution of grain size within the sample. Poorly sorted indicates that the particle sizes are mixed (large variance); whereas well sorted indicates that the particle sizes are similar (low variance).

Raw sample (20x)



Particle selection
(12x and 66x)

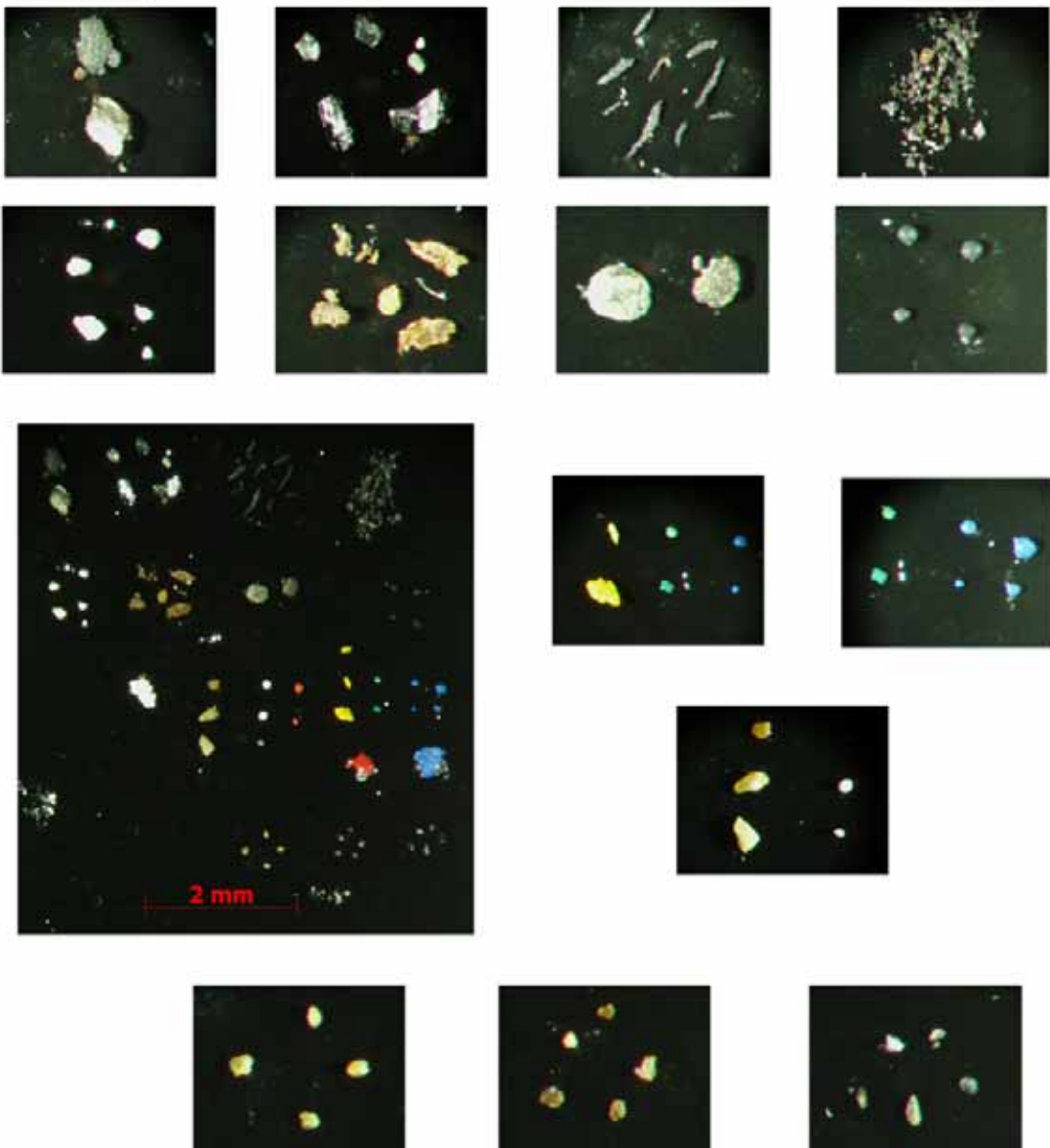

Figure 6.40 Selection of particles from Harbour Bridge Marina boat deck collected on 27/2/08

6.10 May Street, October 2008

This sample was collected in October 2008 at 36C May Street. It was deposited while the occupant was sitting at an outside table. No obvious source was identified at the time, nor was any atypical activity being undertaken in the near vicinity. Meteorological, and in particular wind conditions were not noted at the time of deposition. This later point is important as the collected particles are all several millimetres in diameter, which would mean the source was reasonably local.

The visual characteristics showed a grey glistening surface (Figure 6.41). The morphology of all collected particles exhibited some abrasion with few angular profiles present, but rather a soft round form being common. The elemental signature was not unique and was typical of a soil particle.

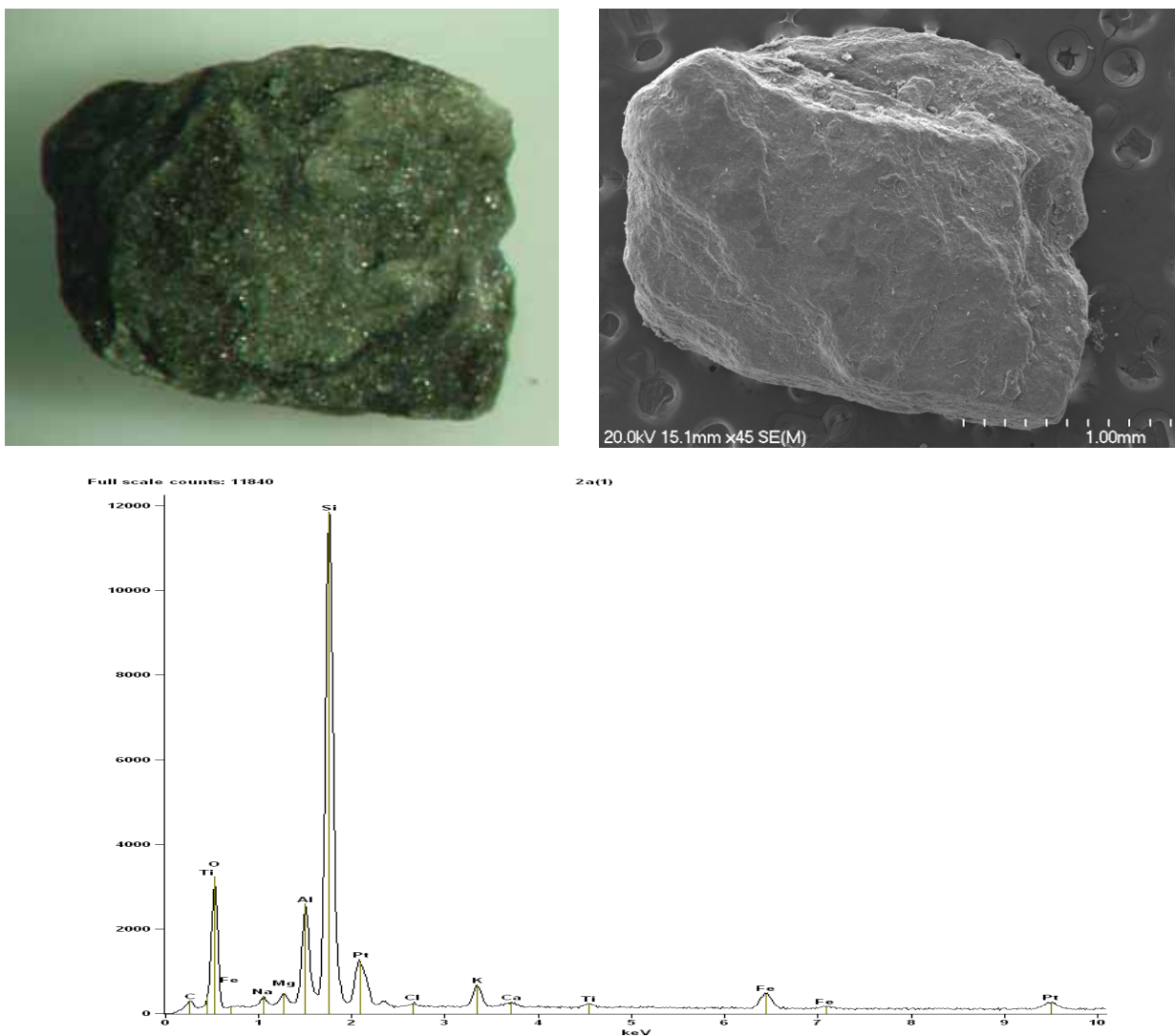

Figure 6.41 Typical soil particle from the collected sample

6.11 Unit 34, 57 Pitau Road (C2009 1077)

This sample was visually similar to other grab samples collected in this area, with nothing unusual present. The period of deposition was not clear. The complainant did not specify a timeframe in which the dust accumulated, i.e. not a recent specific event; he stated dust from the westerly direction was an on-going issue. From the field officers' observations on the day, the dust on the exterior of the building looked like it had accumulated over a long period.

Analysis using the optical microscope (Figure 6.42) showed that the particle profile was dominated by pollen (~60-70%) (white blobs in P9110001 and P9110006), but with a mix of other particles including tyre wear residues (elongated rubbery black particles, P9110009), cenospheres (shiny black spherical balls from shipping emissions, P9110007) and a general background material which could be loosely defined as soil particles and particles from a beach/marine environment (e.g. the finer components of beach sand). This combination gave the overall grey visual appearance.

There was no strong evidence of any coal particles being present, which from previous work show up as dark and often shiny angular particles.

No SEM analysis was performed on this sample.

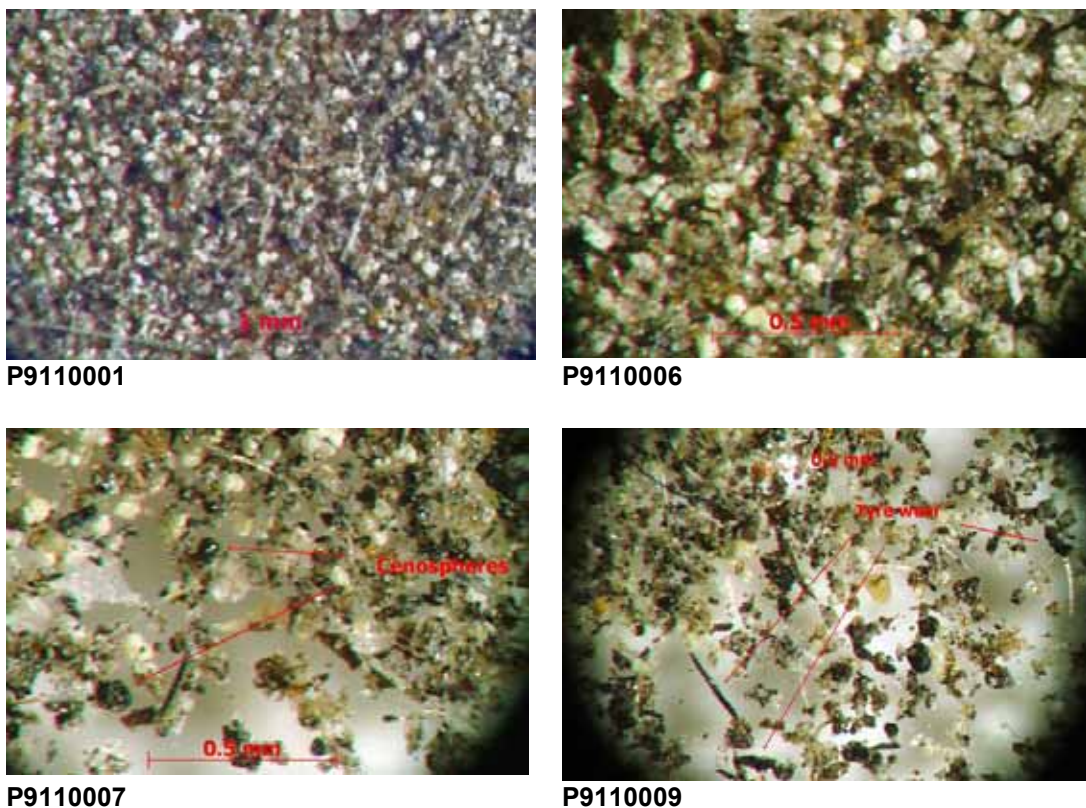

Figure 6.42 Photomicrographs for 57 Pitau Road sample

6.12 Ultimate Motor Group sample

Two samples were collected from this business located on the corner of Totara Street and Hewletts Road. The first was collected 9/4/08 and the second on 7/4/09. Both were very limited in quantity which posed problems in regard to additional chemical analysis. The 2008 sample was collected using lifting tape so further analysis was further limited (Figure 6.43).

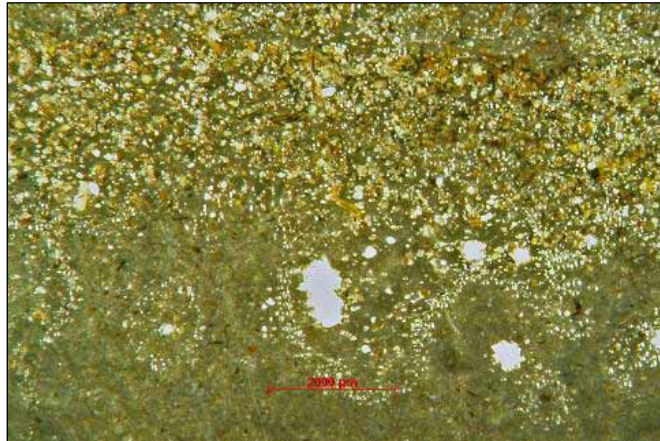

Figure 6.43 Ultimate Motor Group sample, 2008

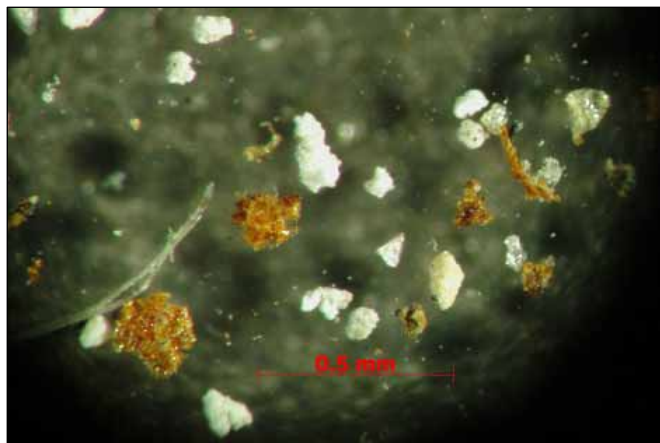
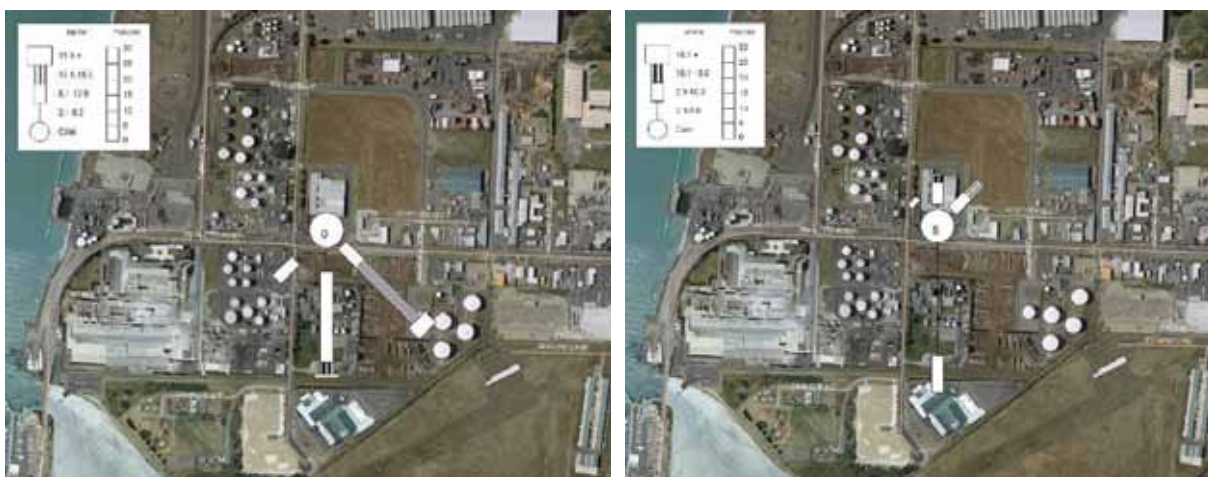

Figure 6.44 Ultimate Motor Group sample, white particles, 2008

Visually the particles of most interest for both collections were strikingly white (Figure 6.44). Both samples also contained a significant portion of other material, examination of which showed nothing atypical when compared with other grab samples from the Mount Maunganui area with the exception that palm kernel fragments (irregular caramel coloured fragments) were present in both samples in reasonable quantities.

Meteorological information was examined for the period during which deposition occurred for these two samples (Figure 6.45). A strong south – southeast component of wind direction was measured in the day prior to the samples being collected. Sources in this quadrant are the Hewlett Road roadway, Port of Tauranga log storage area, Hexion Speciality Chemicals Limited, Terminal (NZ) Limited tank farm, Te Awanui Huka Pak Limited and further afield the Tauranga Airport.



Wind rose
8/4/08 00:00 to 9/4/08 12:00

Wind rose
6/4/08 00:00 to 7/4/08 12:00

Figure 6.45 Ultimate Motor Group sample, showing meteorology for period prior to deposition

SEM analysis of the white particles showed a Si, S and Na composition.

Discussion with Ultimate Motor Group⁶⁷ indicated that they have not experienced the white powder problem for approximately 12 months. Dust from the log storage area on the southern side of Hewletts Road does however continue to be a nuisance.

6.13 135c Marine Parade

Three samples (eastern patio, western patio and northern deck pool cover) were collected from this site on 12 March 2009. Collection was by lift tape and under the optical microscope all three samples showed a similar appearance. Generally there was a collection of marine sediments as well as soil particles, and a lesser quantity of wood fragments and synthetic fibres. A significant portion of the particles had a semi angular and black appearance which helped to give the sample its dark grey colouration.

Further examination of these darker particles was undertaken using the SEM (Figure 6.46). Results showed an elemental signature similar to the sample from the coal storage shed. This occurrence is interesting as particle transport theory would limit the transport distance for particles of this size $\sim 300 \mu\text{m}$ to just several tens of metres in a moderate wind.

⁶⁷ Heays, A., Pollution Prevention Officer, BOPRC, pers. comms. 8 March 2010.

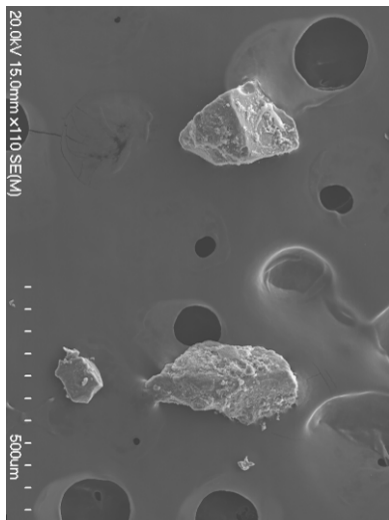

Dark particles from 135c Marine Parade – 12 March 2009

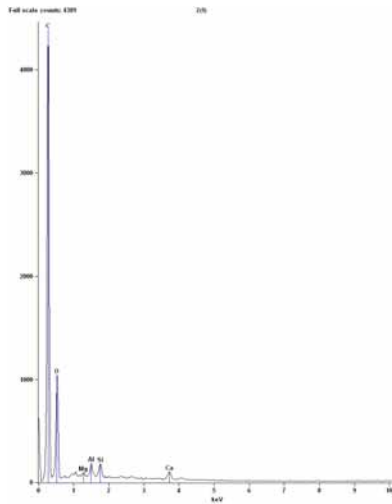

Dark particles from 135c Marine Parade elemental spectrum

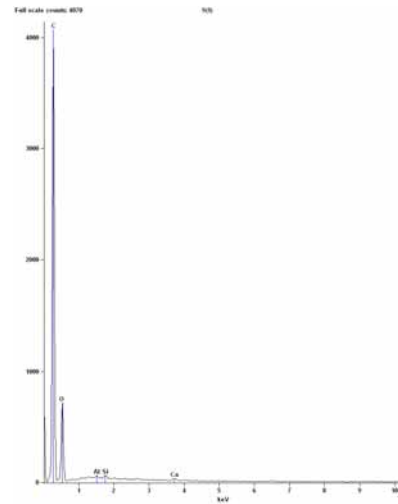

Coal shed sample

Figure 6.46 Marine Parade sample SEM result with coal reference spectra

6.14 Cutters Cove samples (C2009 0371)

Several samples were collected from the front and rear deck of the property on 10 March 2009. A second set of samples was collected from Apartment 301 in the same complex from the westerly and north easterly decks. Collection was by brush and pottle.

Viewed using the optical microscope (Figure 6.47) the samples had a number of similar characteristics. Both sets of samples had an abundance of dark non shiny particles with a mixture of angular and non-angular profiles. Several of these particles were removed and analysed further with the SEM (Figure 6.48), and the results show a similar profile to the coal shed sample. The sample collected from the westerly deck of Apartment 301 showed an absence of the dark particles but rather a profile typical of the coastal marine environment (an abundance of quartz particles) along with the presence of some cenospheres.

As with the sample collected from 135C Marine Parade it is interesting to find particles of this size $\sim 400 \mu\text{m}$, which appear to be coal, in this location some distance ($>1 \text{ km}$) from the largest source of coal particles.

If the coal facility was the source it would be expected that the deposition rates closer to the facility would have been much greater than at the complainant's property. It is therefore surprising that no complaints were received from other residents living closer to the coal facility.

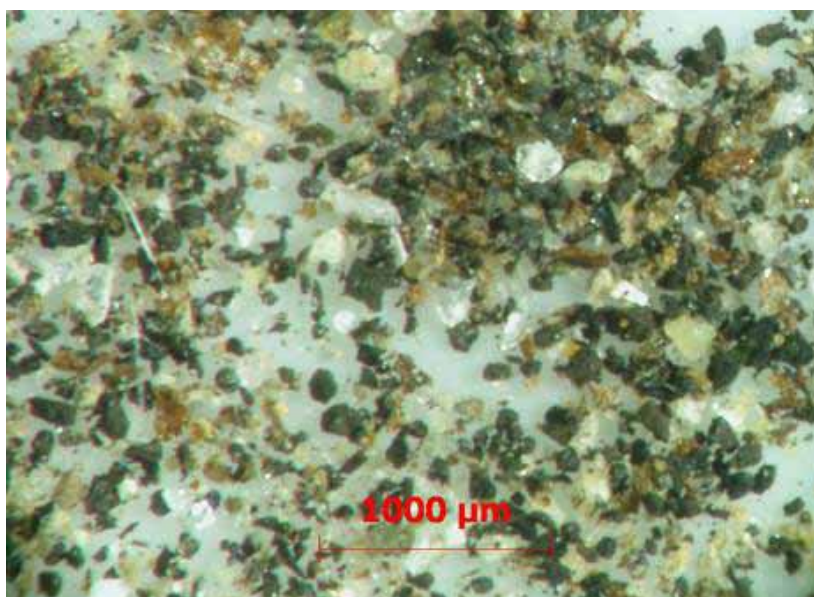

Figure 6.47 Image of sample from cutters cove 136 marine parade Apartment 301 north easterly deck.

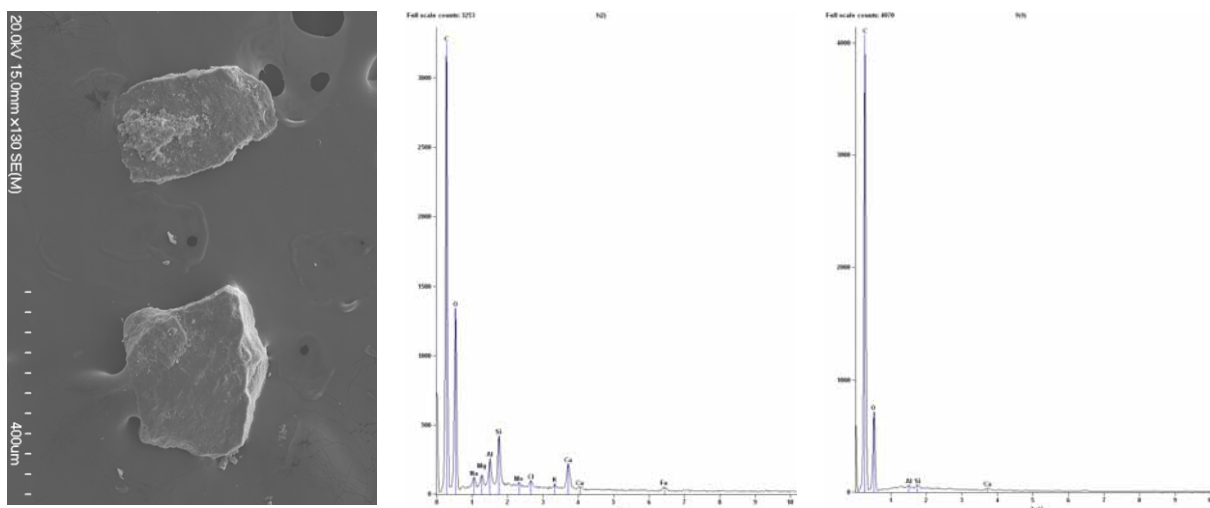

Figure 6.48 SEM output of selected particles from Cutters Cove, 136 Marine Parade, Apartment 301, north easterly deck

6.15 135 Totara Street, Chumneys Lunch Bar (C2009 0348)

This sample was collected on 11 March 2009 from the shop floor (Figure 6.49). Sampling was by brush and pottle. To the naked eye the sample had two components, a light grey finer fraction and a dominant brown/tan larger fraction. The larger size fraction consisted of palm kernel and wood fibre fragments. The finer fraction was well sorted with particles ($\sim 100 \mu\text{m}$) typically representative of those in a coastal environment along with particles of a soil origin.



Figure 6.49 Sample collected from Chumney's Lunch Bar

6.16 24B Miro Street

Collected on 8 April 2009, this bag sample was sourced from the north western side of the dwelling under a veranda. To the naked eye the sample exhibited a dark grey appearance with speckles of lighter coloured particles. Under the optical microscope coastal sediments and soil particles were dominant. Biological material such as sporangia⁶⁸ was also abundant. Palm kernel and wood fragments made up approximately 5-10%. Darker particles were only a minor component with the majority of these being cenospheres. Glass fibre filaments were also noticeable. SEM outputs for selected particles are shown in Figure 6.50.

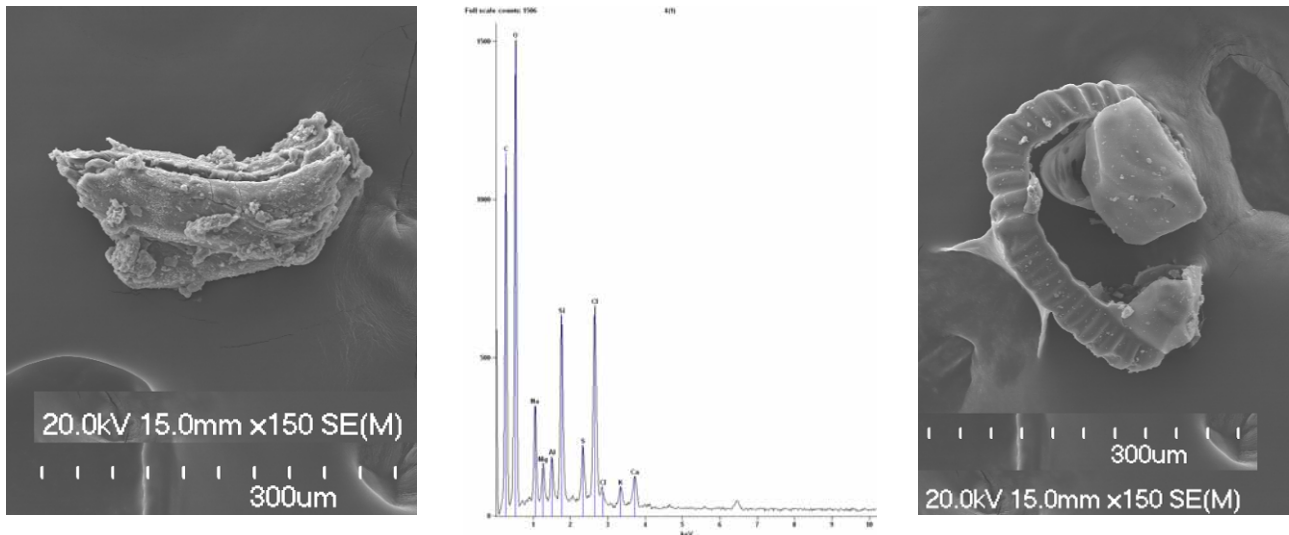

Figure 6.50 SEM output for several particle types (left, soil particle (with SEM), sporangia image on the right) from 24B Miro Street

⁶⁸ Ferns are dispersed by air-borne spores which have a thick protective wall that surrounds a living cell. Large numbers of spores are formed inside spore sacs (sporangia) that are usually located on the underside of fronds. As a crest or file of cells (annulus) in the spore sac wall dries out, it contracts, slowly ripping the spore sac in half. A point is reached when the two halves rapidly come together again, throwing the spores out. Although not present in this sample an example of the spores are shown in the sample collected from the Tauranga Marina, see Section 6.9.1.

6.17 2/30 Miro Street (C2009 0360)

Two pottle samples were collected from this property. On 13 March 2009 a sample was collected from the bathroom on the eastern side of the dwelling, and on 23 March 2009 a sample was collected from the soffit. To the naked eye the samples were dark grey in colour.

Under the optical microscope the 13 March 2009 sample consisted of a well sorted selection of particles, approximately 60% of these were black in colour and were a mixture of angular and cenosphere particles. The angular particles had characteristics similar to the coal shed sample collected earlier and several of these were extracted for further SEM analysis. The remaining matrix of particles was once again typical of a coastal environment with quartz particles common. Soil particles were also evident. A large number of filaments were also present.

The SEM analysis of the darker particles revealed an elemental signature similar to that of the particles from the coal storage shed. The filaments were also checked under the SEM and were determined to be synthetic fabric filaments (such as acrylic⁶⁹) (Figure 6.51 and 6.52).

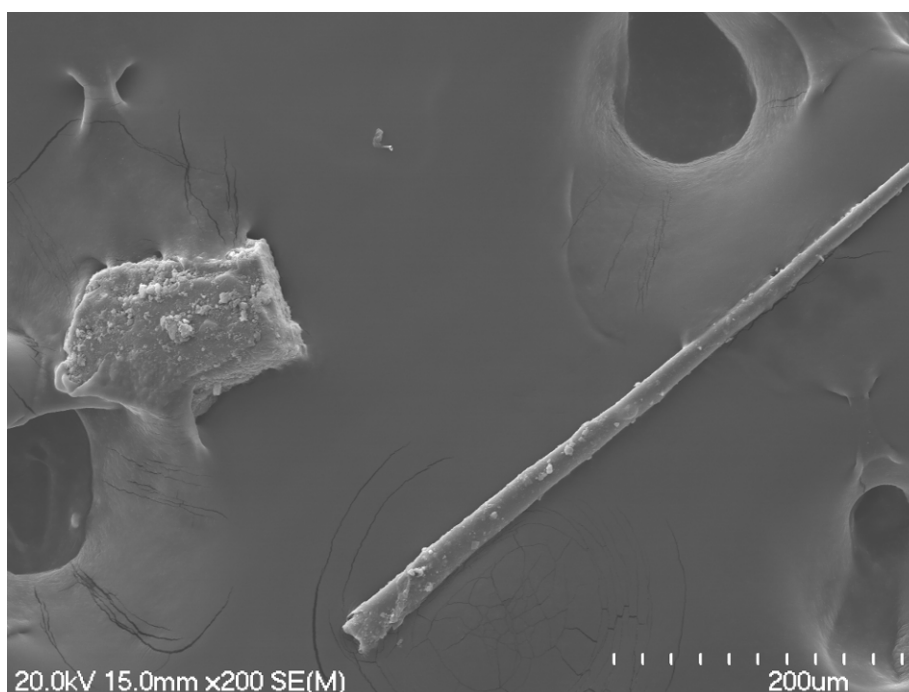

Figure 6.51 SEM output for several particle types from 2/30 Miro Street

⁶⁹ McCrone, W.C., 1973, *The Particle Atlas, Edition 2, Volume II The Light Microscopy Atlas*, ISBN 0-25040008-1.

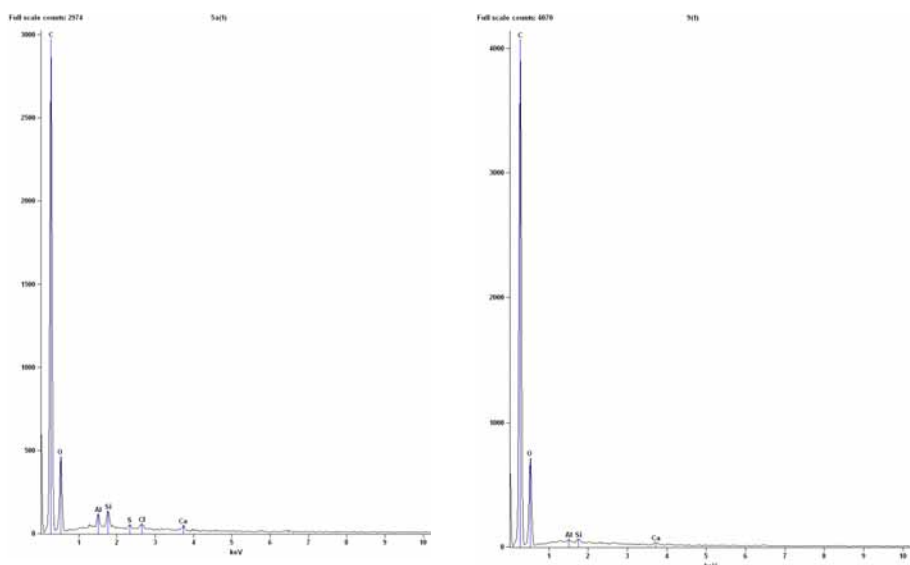

Figure 6.52 SEM spectra for several particle types from 2/30 Miro Street

The sample collected from the soffit was primarily pine pollen covered in a black residue (Figure 6.53).

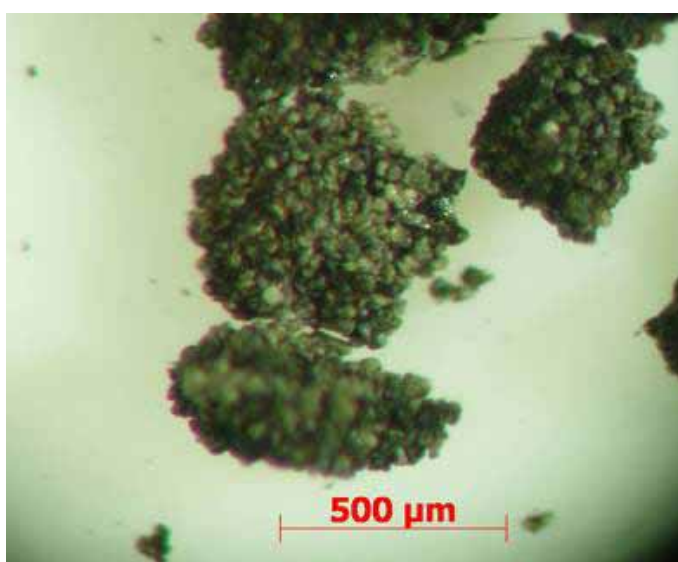

Figure 6.53 Optical microscope image showing pine pollen collected from 2/30 Miro Street

6.18 Kippen Way

Collected on 3 March 2009 this sample had a light grey appearance to the naked eye. Under the optical microscope it consisted of four main components in order of dominance:

- Quartz particles
- Pine pollen
- Tyre wear particles
- Cenospheres

One of the tyre wear particles was included in the SEM analysis for completeness (Figure 6.54). Silicon, manganese and aluminium were the dominant elements within the elemental spectra.

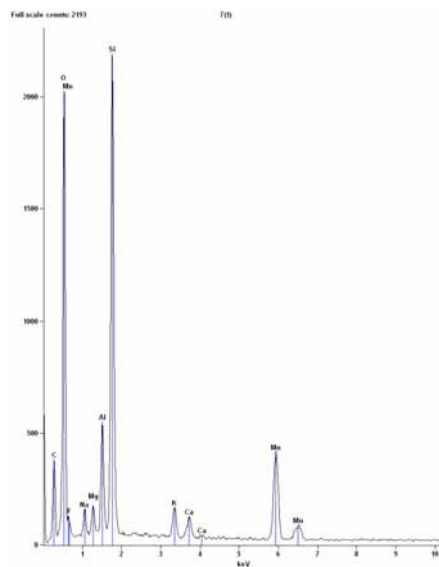
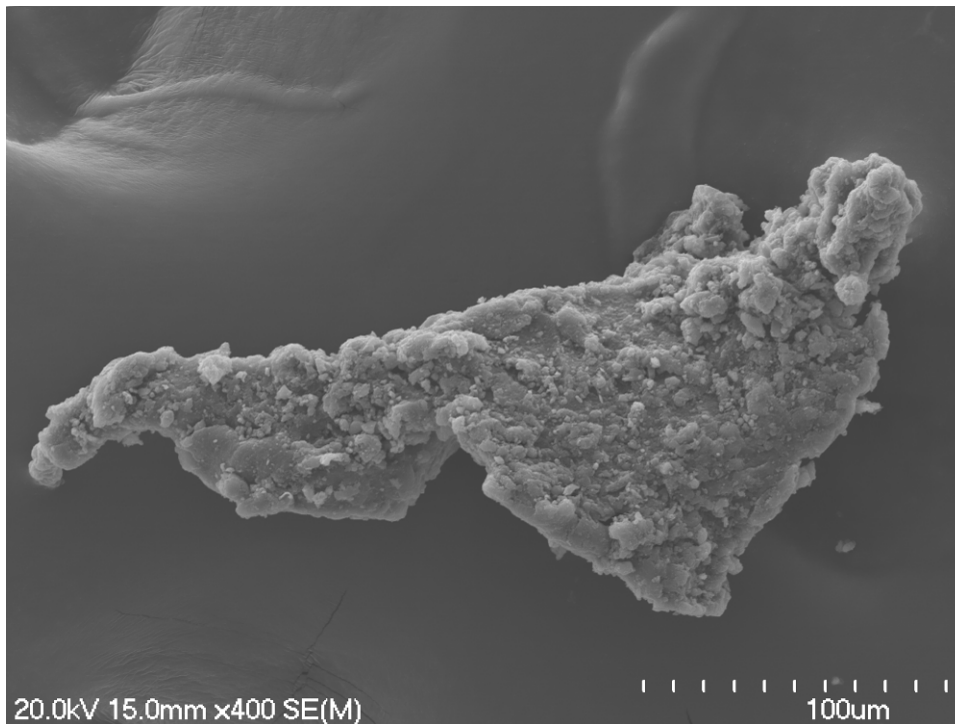

Tyre wear particle

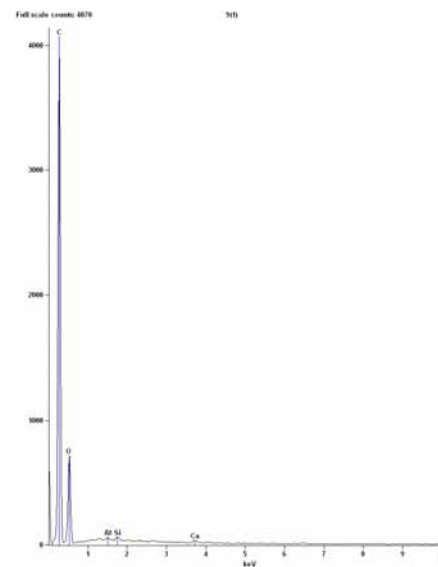

Coal

Figure 6.54 SEM microscope image and spectra for a tyre wear particle collected at Kippen Way.

6.19 Tauranga Marina Society, 4 September 2008

This bag sample was collected on 4 September 2008, from the Tauranga Marina on a boat berthed in D Dock (Figure 6.56). To the naked eye the collected dust was light grey in colouration. Under the optical microscope the particles were well sorted with an average size of ~100 μm . The dominant particles were lighter in colour and typical of coastal sediments seen elsewhere in other grab samples with quartz particles being the most common. The darker fraction of particles was made up of tyre wear particles, cenospheres and black angular particles, in decreasing order of abundance.

The cenosphere and black angular particles were selected for SEM analysis. The angular particle had a strong carbon peak along with a signature for sulphur, suggesting a combustion by-product (Figure 6.57).

Wind analysis for the preceding period of time shows a strong north-easterly/easterly pattern (Figure 6.55).

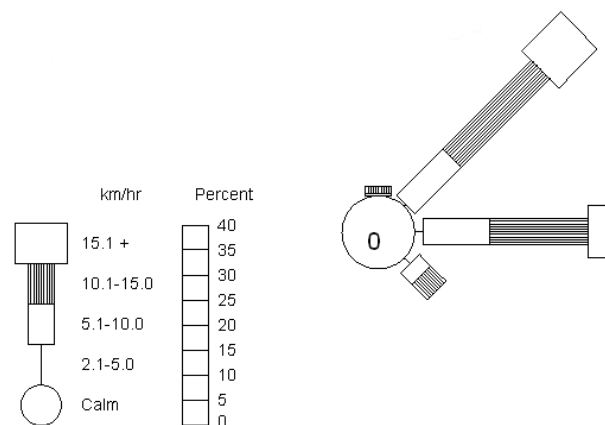

Figure 6.55 Wind rose from data collected at the Totara Street monitoring station. 3/9/08 00:00 to 4/9/08 14:00



Figure 6.56 Aerial photograph showing the Marina on the left (with sample area highlighted) and upwind sources based on the wind rose above

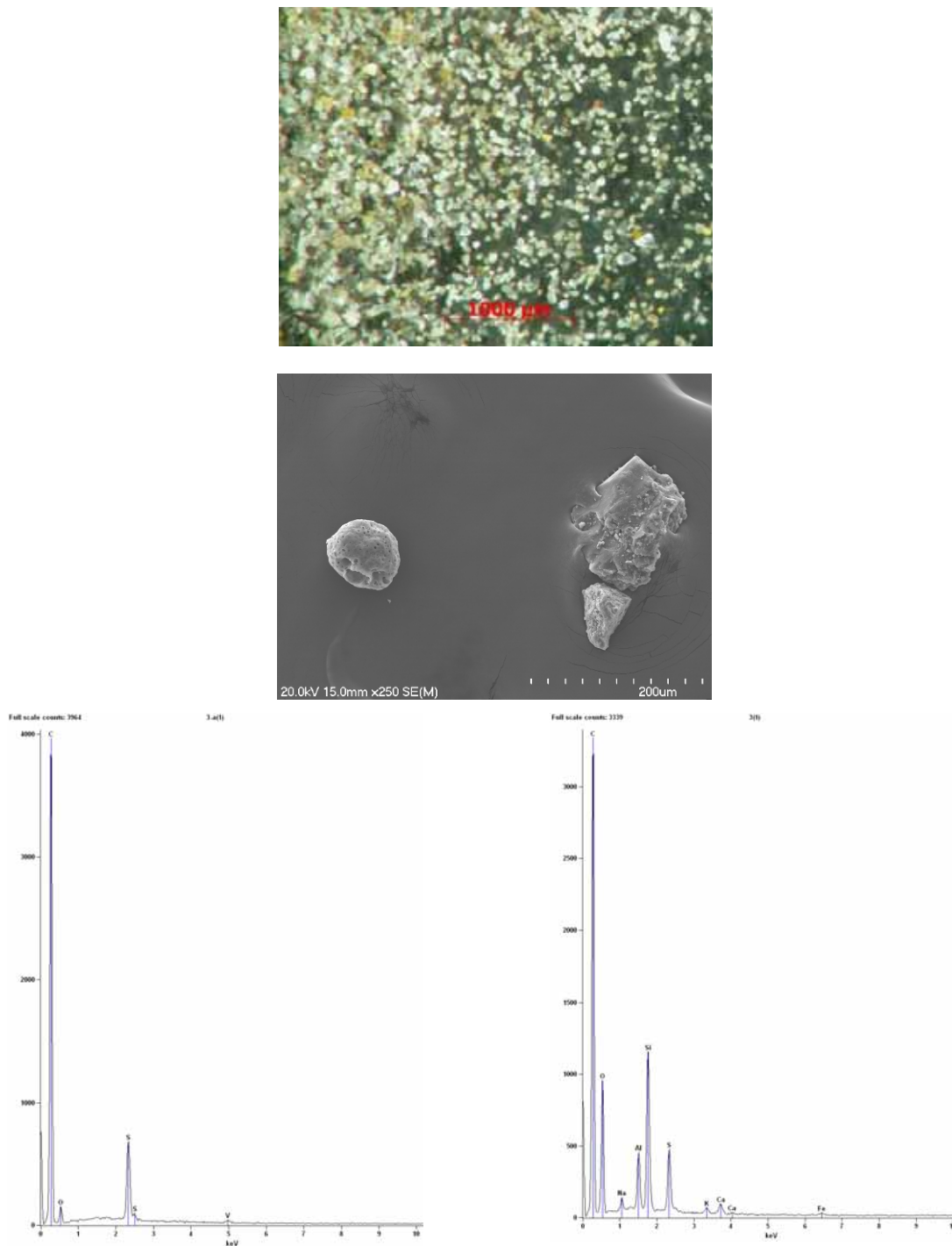

Figure 6.57 Optical microscope and SEM images of the cenosphere and coastal sediment particles which were common in the collected sample, left spectra is for the cenosphere, right for the sediment particle

6.20 144 Oceanview Road, 12 April 2010

This property is on an elevated site with unimpeded views of the Mount Maunganui area in all directions. Two pottle samples were collected; one from the north facing deck and the second from the southwest facing deck. The accumulation period was estimated to be in the order of several weeks.

To the naked eye both samples had a medium grey colouration.

Under the optical microscope both samples had a common sticky appearance and were generally well sorted with a common particle size of ~50 µm (Figure 6.58). Larger particles were present with some biological and wood fragments in the order of several hundred microns in size. The biological particles consisted of insect casings, spore spores and pollens (both pine and the caramel coloured triangular species (see 6.9.1) which commonly appears in many of the grab samples to date). Palm kernel fragments were also very well represented.

In addition to the above, the most common components were crystalline particles with a dominance of quartz, the occurrence of these particles is similar to the beach samples collected from the open coast, albeit of a finer size fraction. This is not unexpected due to the property's proximity to both the estuarine and open coast environments.

A reasonable percentage (possibly 15%) of darker particles were also present. These consisted of burnt wood fragments, based on the fibrous appearance cenospheres and the ever present tyre wear particles. These were all generally greater than ~20 microns with some of the partially burnt fragments making up the larger particle size fraction of the sample.

Overall the particles within these two samples were similar to those collected elsewhere with nothing unique appearing. From visual examination there didn't appear to be any coal particles which have been raised as a possible component in other collected samples from the Mount Maunganui area. Health wise the particles were of a size fraction that would not be inhalable but rather could cause visual nuisance effects.

Northern deck

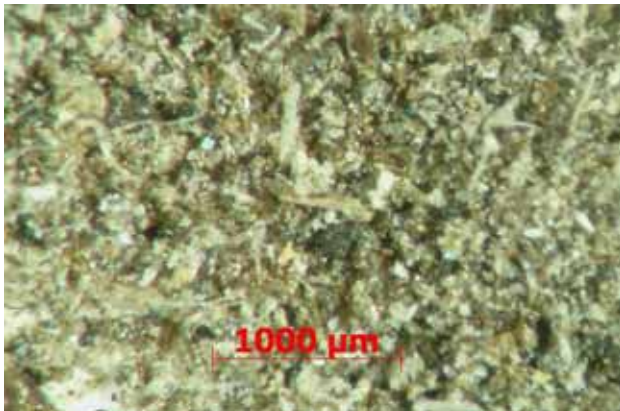

20x magnification

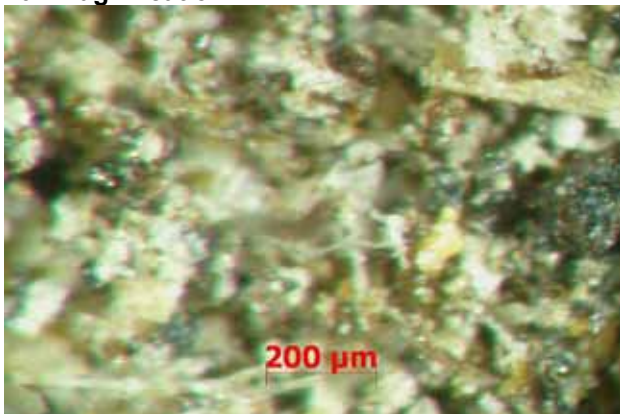

66x magnification

Southwest deck



20x magnification

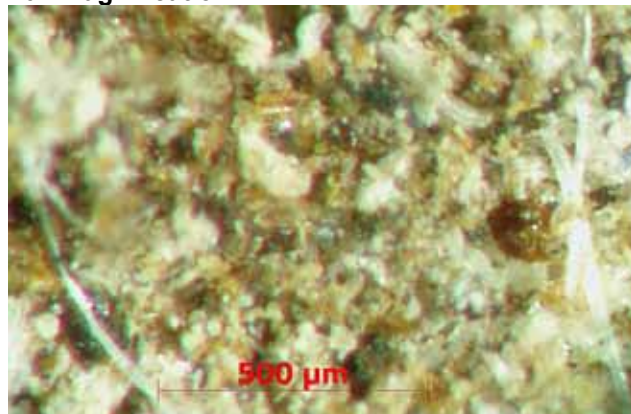

66x magnification

Figure 6.58 Optical microscope images for Oceanview Road sample

6.21 Port of Tauranga - Sulphur Point area samples

Four dust samples were collected on 10 March 2009 from locations around the port area at Sulphur Point (Figure 6.59). See Figure 6.2 for locations.

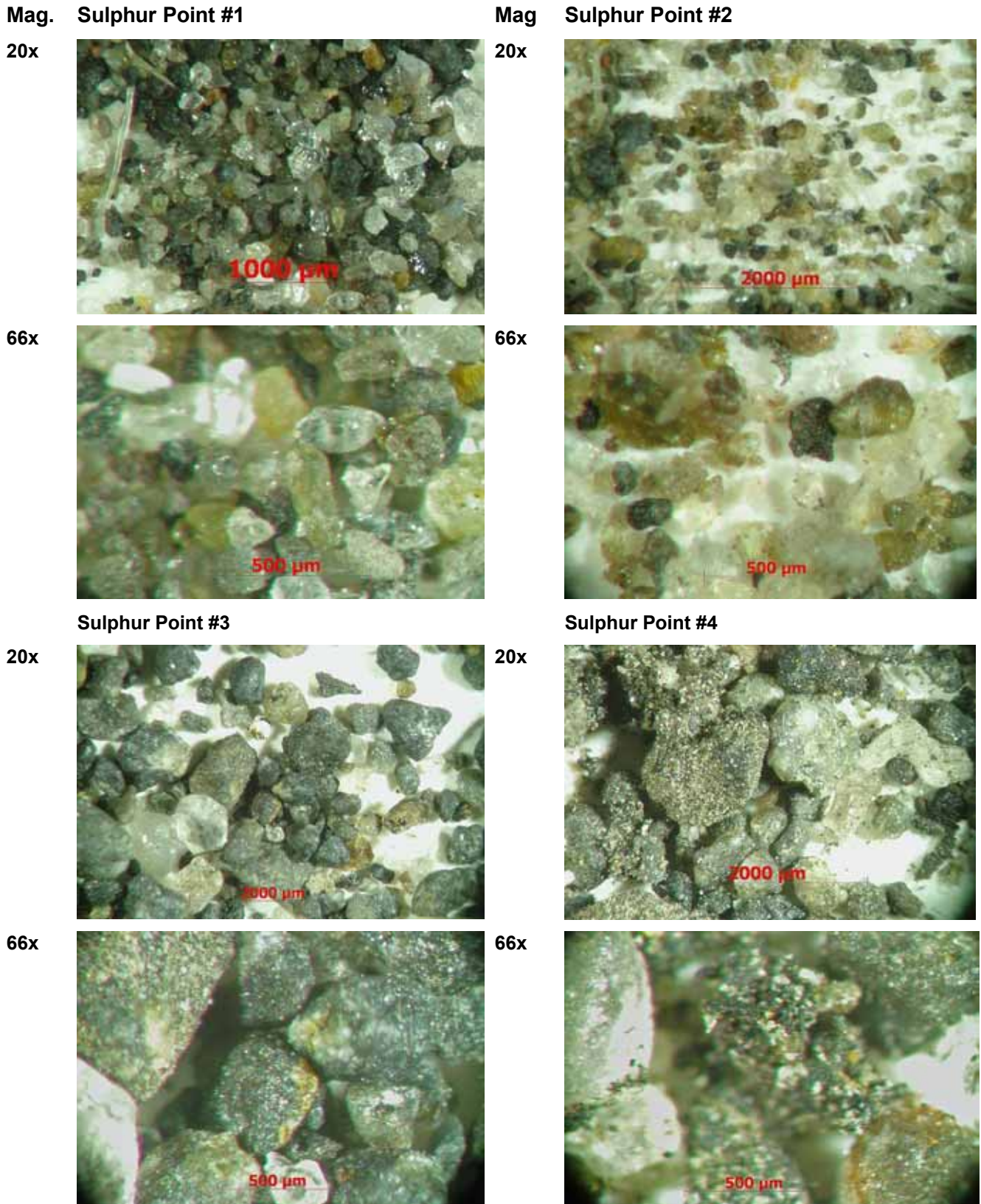
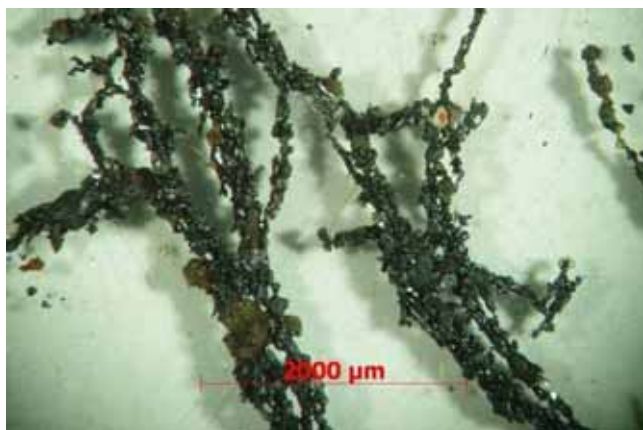

Figure 6.59 Four dust samples collected from locations around the port area at Sulphur Point.

Each of the four samples were analysed using the optical microscope, the following are comments relating to each of these samples.

- Site #1 – to the naked eye the sample had a light to medium colouration. Under the microscope the sample had the particle appearance similar to those collected from the open coast and Pilot Bay beaches (see Section 6.1). The difference being that the particles were in the very fine sand range rather than medium sand. This is not unexpected as the intertidal estuarine environment is only 100 m to the north. Cenospheres and tyre wear particles were also present although not abundant. Approximately 5% of the collected sample reacted positively to magnetism.
- Site #2 – this sample had the same general visual characteristics as that collected from Site #1, although there was a greater presence of tyre wear particles, wood fragments and clear filament strands. A similar proportion of the sample reacted to magnetism. The significant difference between this sample and #1 is the wider range of particle sizes; ranging from ~50 μm to ~1 mm.

Particles responding to magnetism.



20x mag.

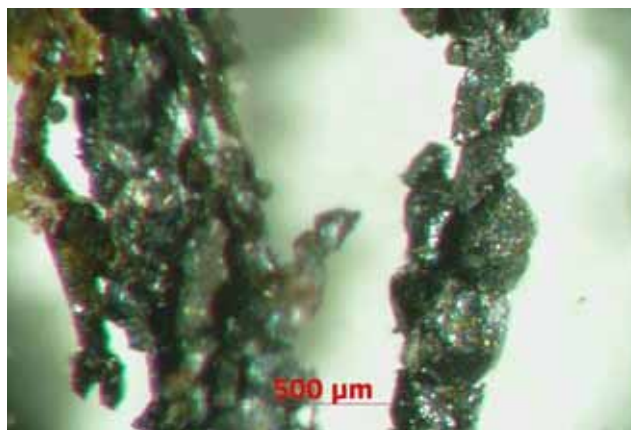

66x mag.

- Site #3 – Dark grey in colouration, with particle sizes ranging from ~50 μm to ~1 mm. The particles had a well-rounded appearance and were dominated by a greater presence of darker minerals. Tyre wear particles were abundant and approximately 5% of the sample reacted to magnetism.
- Site #4 – The sample to the naked eye had a dark grey colouration similar to #3. The particle size range was also similar to #3, while most of the particles had a rounded appearance, possibly as a result of abrasion. The sample also contained rust, paint fragments and wood fibre particles, along with abundant tyre wear particles. The underlying particle pattern was still similar to a sample from a beach environment although there was a dominance of darker minerals and possibly a dark bitumen particle contribution. Again ~5% reacted positively to magnetism.

Because of the typical and expected nature of these samples only a limited number of particles were selected for SEM analysis, all from the Site #1 sample. The common darker mineral that was present in all samples was selected along with one of the less common shiny black particles. The former was rich in Si, Al, Mg and Ca (and due to the coastal environment could be from the pyroxene or amphibole group of minerals), the latter returned a strong Fe and Ti signature (which would line up with the measured magnetic attraction) hence suggesting ilmenite minerals.

6.22 **Samples collected from a roadway, 2008**

During this investigation several samples were collected from roadways within the Mount Maunganui area. The collection methodology was quite simple and involved collection of material by two methods. The first involved adhesive sheets attached to the underside of the wheel arch of a vehicle. For this sampling technique the Totara Street roadway was driven on. The second sampling involved sweeping and then lightly abrading the sealed surface and then collecting the loosened material. Both types of samples were visually examined using the stereo microscope.

The wheel arch samples showed a wide range of particle sizes from tens of microns through to several millimetres. Particle type was variable with soil particles and palm kernel being present but heavily dominated by tyre wear particles.

The direct sticky tape samples from the roadway itself as expected also contained an abundance of tyre wear particles and also particles of a brown/black appearance which would be particles of bitumen. It is feasible that these two types of particles interact and often merge, as the tyre wear particles under the SEM consist of rubbery material coated with smaller particles, thereby giving it an overall appearance of being "crumbed".

6.23 **Grab sample summary**

This section has contained findings from analysis of over 30 grab samples. Several could be regarded as being largely homogenous, such as those containing wood fibres and several containing palm kernel. For both types of samples the source was simple to define.

The open coast beach and Pilot Bay samples along with the coal shed sample provide key reference samples. The beach sediment samples contained particles that were seen in most of the grab samples although the size ranges were understandably different. Much of the soils for the area of interest have this coastal origin. The coal shed reference sample was also valuable, particularly in the early part of this investigation when the transfer facility was being used for this particular product.

However for the majority of the grab samples the particle profile was one of a heterogeneous nature. To the naked eye the collected material often had a dark grey to blackish colouration but under the optical microscope the samples were non-uniform in colour characteristic.

This heterogeneous mixture of particles consisted of soil particles and those of a coastal origin, together with anthropogenic particles such as those from tyre wear which were the most common, particles from particular types of combustion, such as cenospheres from shipping emissions, a range of fibres, as well as a seasonally present selection of pollens and other biological matter such as sporangia. Around certain areas paint globules were also present. Woody material was also detected in some samples in close proximity to log handling areas at the port.

The base and majority of most samples would be defined as typical urban dust (this will be discussed further in the next section), however due to the elevated level of activity such as volumes of vehicular transport and port (and related) activities in the area the quantities are often enhanced to a point where they become a regular visual nuisance if meteorological conditions are conducive.

Part 7: Samples from other locations within the Bay of Plenty

This section of the report discusses a collection of samples from other urban locations in the Bay of Plenty. This exercise will give some context to what is being collected at Mount Maunganui.

7.1 Rotorua

Samples were collected within the Moses Road and Te Ariki Place area within the Ngāpuna subdivision in Rotorua. Industrial activity is also present within this subdivision; many of the businesses are similar in activity to those light industries present at Mount Maunganui. A TSP 24 hour sampler was used for data collection, sample concentrations ranged between 40 and 50 $\mu\text{g}/\text{m}^3$. Typical particles collected and the associated SEM elemental spectra are shown in Figure 7.1

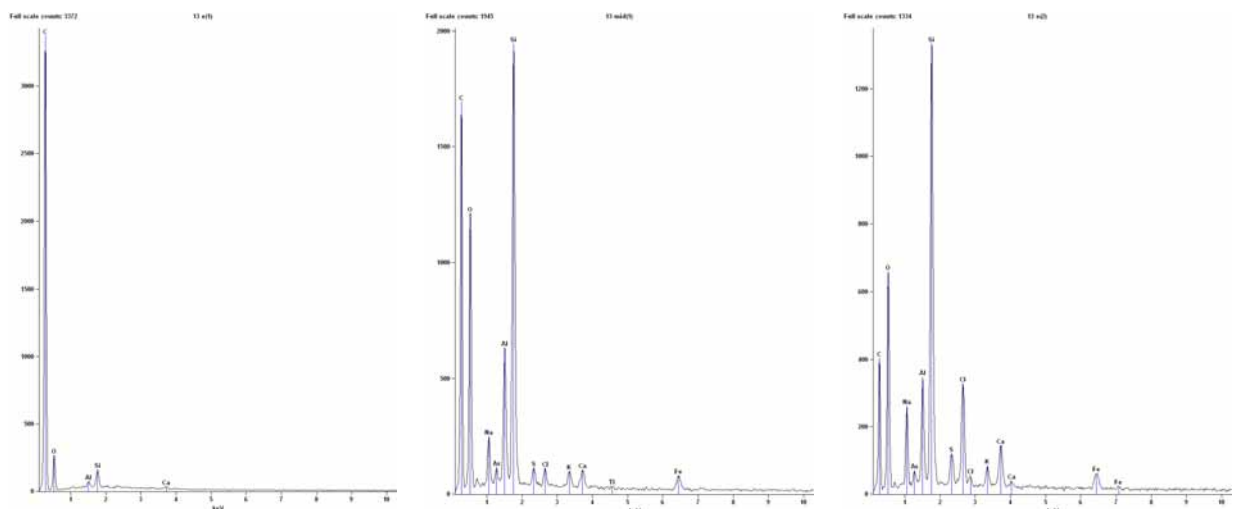
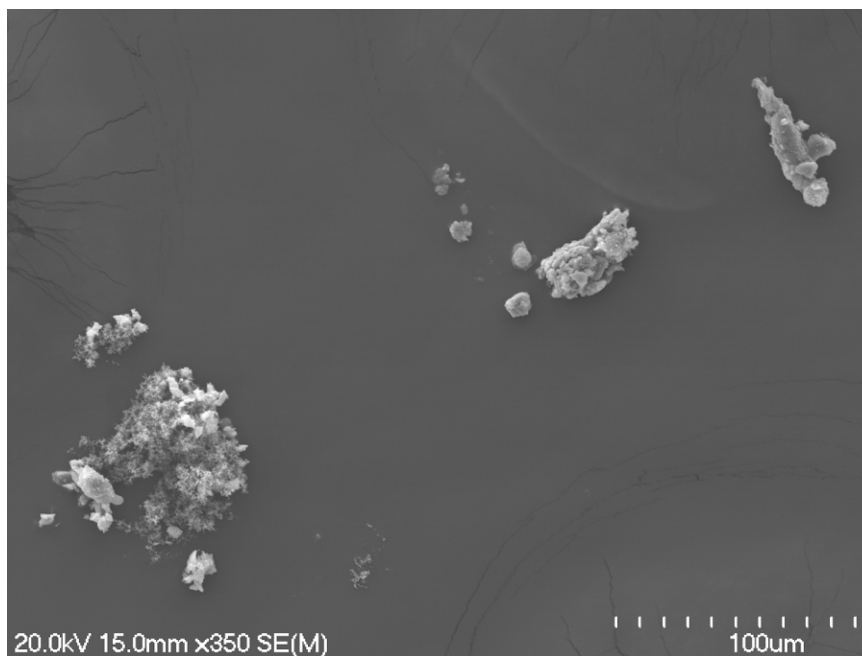

Figure 7.1 Ngāpuna subdivision particle example.

7.2 Te Puke

TSP samples were collected from a property near the intersection of SH2 (AADT ~ 18,000) and Te Puke Quarry Road. A Solarvol dust sampler was used for this particle collection. Samples were collected over a 24 hour period. Concentrations ranged between 7 and 52 $\mu\text{g}/\text{m}^3$ for the period of interest.

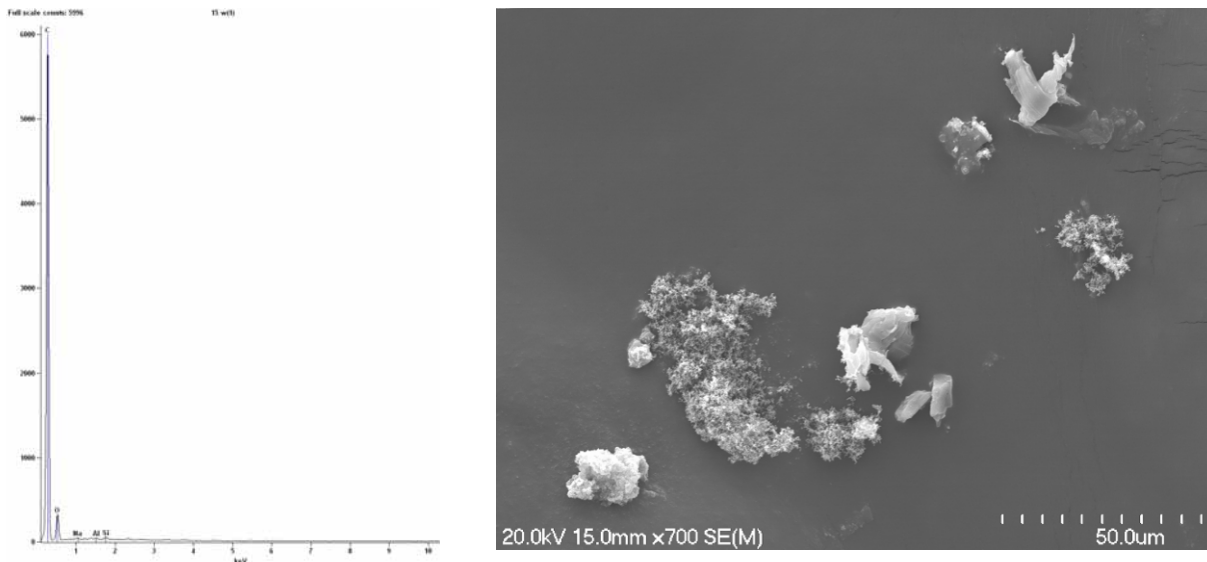

Figure 7.2 Te Puke particle example

7.3 Whakatāne

Several samples (Figures 7.3 and 7.4) were collected from a Pouwhare Street property which backs onto Landing Road (~AADT = 14000). The sample was collected from a window ledge which faces Landing Road, two weeks after the surface had been cleaned.

This site would represent a general urban environment profile with the inclusion of one of the busier feeder roads in Whakatāne being with 60 m of the sampling site.

For the two week period in July when the sample accumulated a rainfall total of 120 mm was recorded in three events at the nearby Whakatāne Air Quality monitoring site. However the presence of the window eave along with the southern aspect provides the ledge with a reasonable amount of protection.

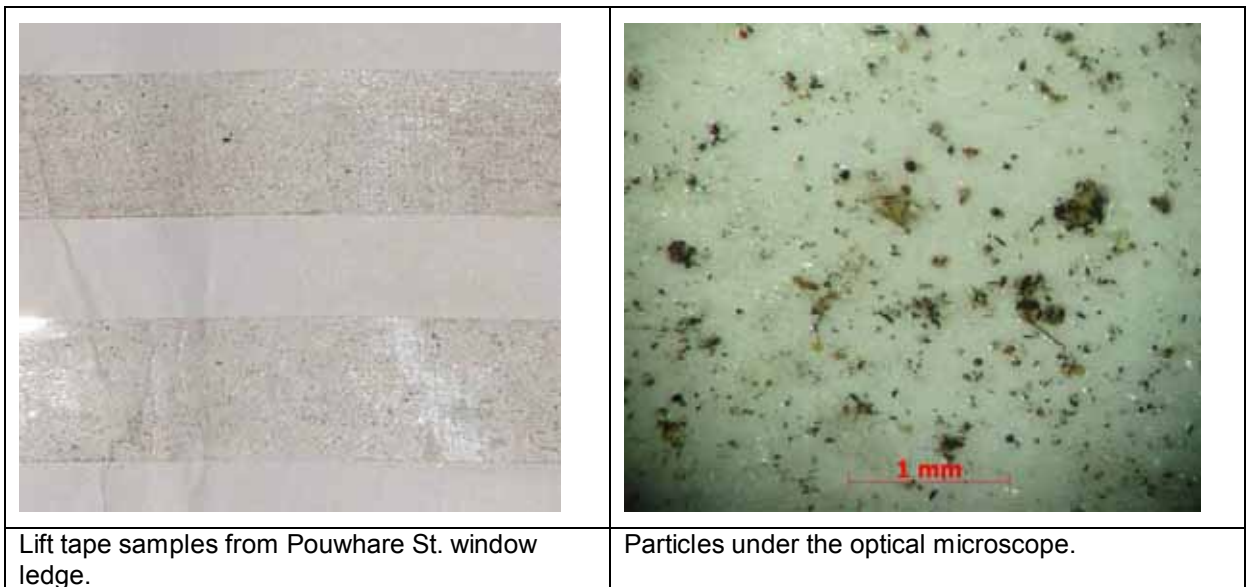

Figure 7.3 Whakatāne particle example.

The particulate profile was similar in composition to those collected in Mount Maunganui although quantities were less. The dark particles (Figure 7.3) were dominant and consisted of tyre wear particles, some soil particles and at this time of the year (Winter) some particles from domestic heating sources. Figure 7.4 shows the SEM output for a selection of particles collected at the Pouwhare Street site and shows patterns common for a typical urban dust.

7.4 Discussion

The particulate profile for all three locations was similar in composition to those collected in Mount Maunganui although quantities were less. The dark particles were dominant and consisted of tyre wear particles, some soil particles and for the Whakatāne site some particles from domestic heating sources. The SEM output for the selection of particles collected at all sites showed a pattern typical of general urban dust.

North particle

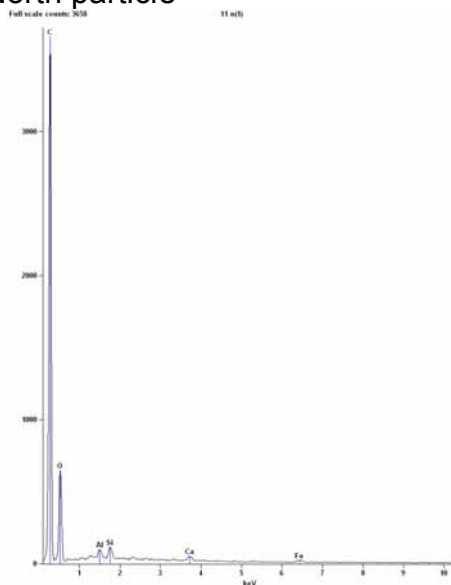

East particle

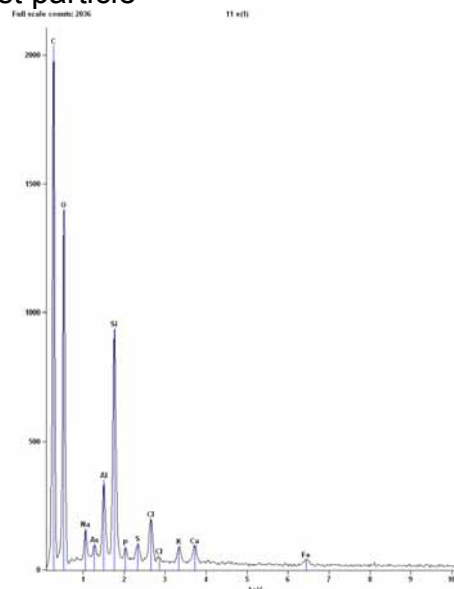

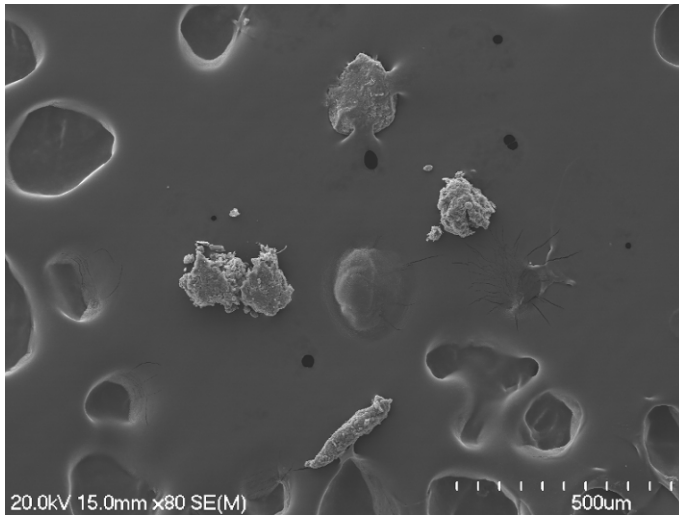

West particle

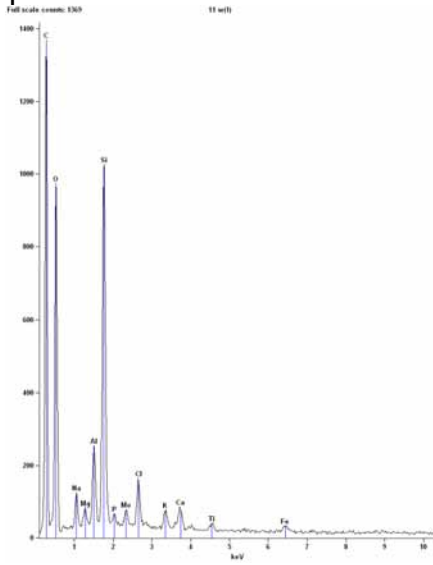

South particle

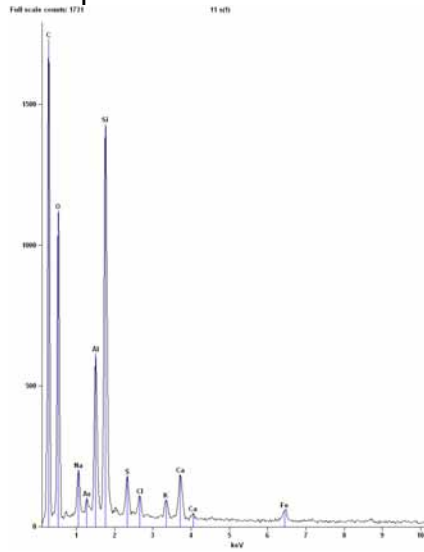

Figure 7.4 Whakatāne particles SEM output

Part 8: Directional Dust Detector programme

This section of the report discusses the ambient monitoring work undertaken by Bay of Plenty Regional Council during the 2008/2009 spring and summer period.

8.1 Directional dust detector programme

In order to gain a better understanding of the spatial distribution and quantity of nuisance dust experienced within the Mount Maunganui/Sulphur Point area a monitoring programme was devised in late 2008.

8.1.1 Meteorological data

Rainfall data collected at the Tauranga City Wastewater Treatment plant (Figure 8.1) showed several significant rainfall events during the early part of the monitoring program. Between 20 and 30 mm was recorded on a daily basis. Numerous other smaller events were recorded but at less than 10 mm/day they would have only a very minor to nil effect in providing dust suppression for a sustained length of time or surface cleaning ability (dust transport into the stormwater network).

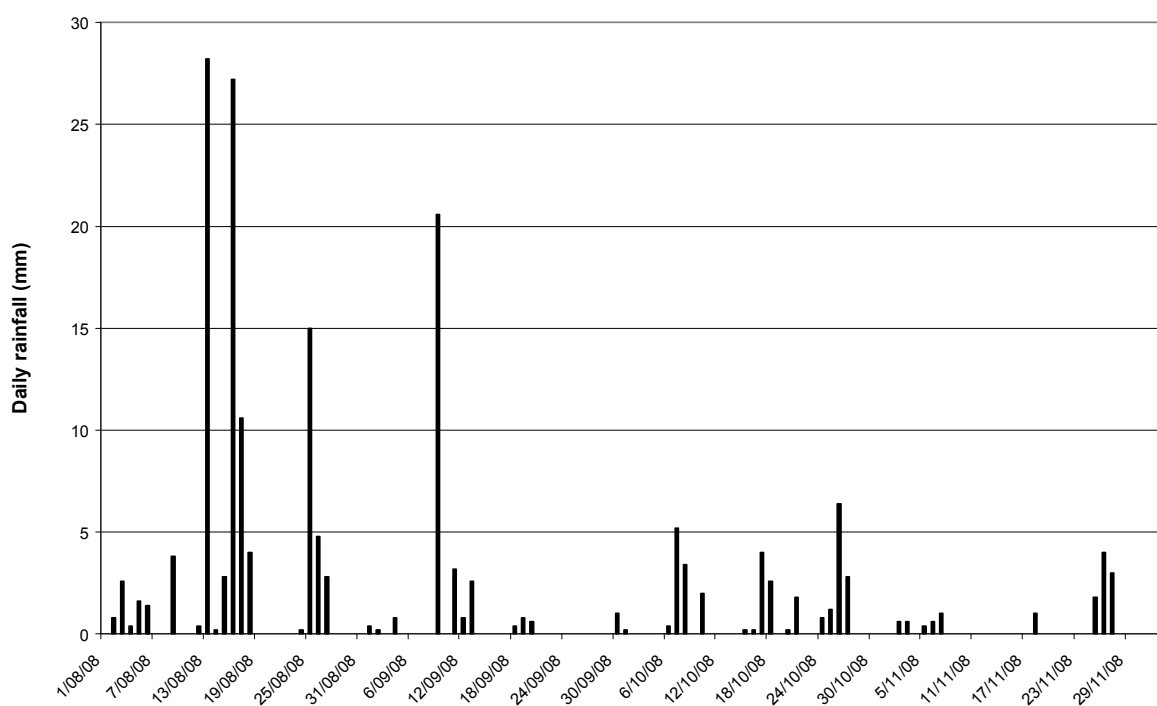

Figure 8.1 TCC Wastewater treatment plant rain gauge record for the monitoring period

The wind data for the sampling period is summarised in Figures 8.2 and 8.3, and wind roses for each weekly sampling period are shown in Appendix 5. The full period rose (Figure 8.2) shows a dominance of winds from the west/southwest quadrant, which is in line with the longer period data shown in Section 3.6. The sea breeze effect is also visible as this would have become dominant towards the end of the monitoring programme. Wind speed data shows the effect of diurnal heating, with increases occurring in the mid to later part of the day, this is important in relation to nuisance dust transport as this coincides with the period of higher human activity.

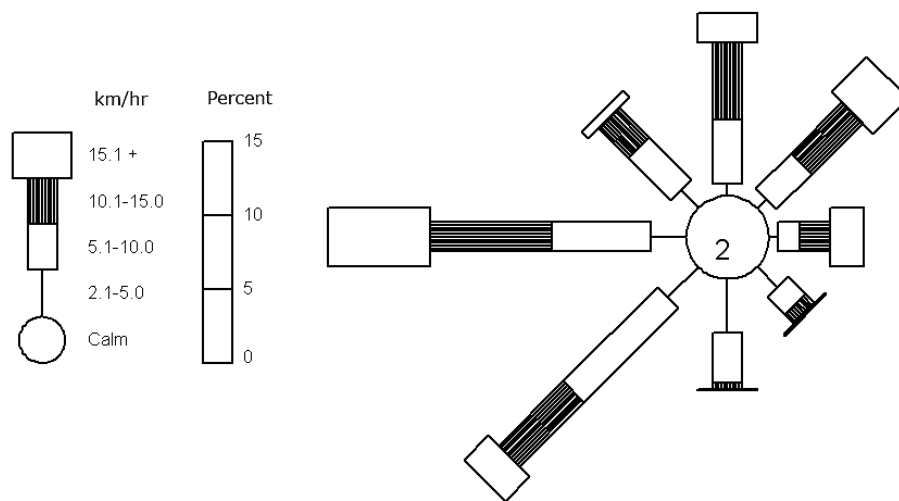

Figure 8.2 Wind rose for the field sampling programme in Mount Maunganui, 13th August to 3rd December 2008

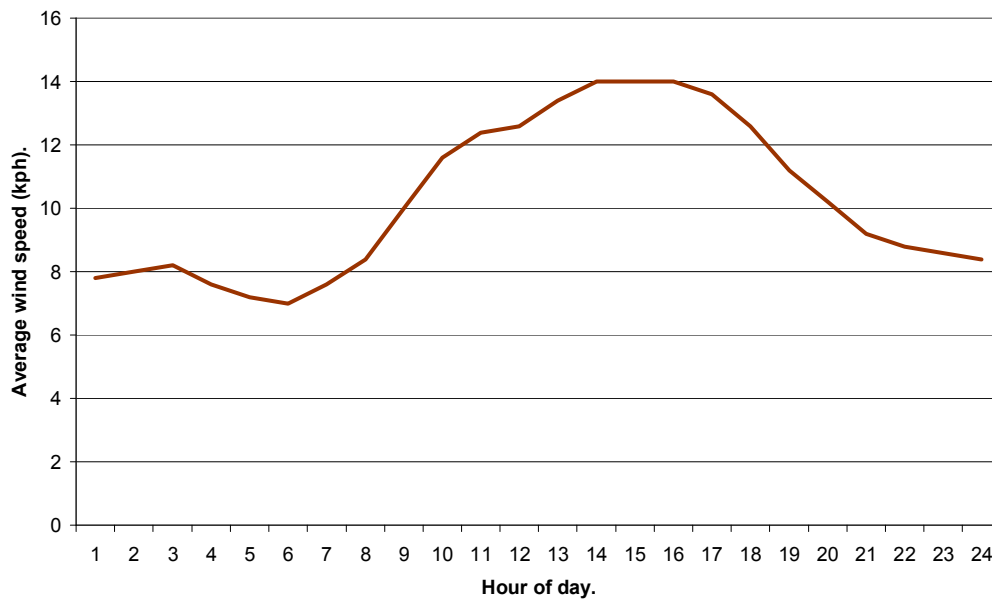

Figure 8.3 Diurnal average wind speed for the field sampling programme in Mount Maunganui, 13 August to 3 December 2008

8.1.2 Methodology

A full description of the methodology is found in Appendix 4, a brief summary is documented below.

The field equipment for this programme was based on the technique of Datson & William (2007)⁷⁰. The field sampler consisted of a transparent adhesive film wrapped around a vertically mounted rain protected cylinder with true north marked (for alignment, repeatability and analysis) (Figure 8.4).



Figure 8.4 Directional dust sampler (note: adhesive film is positioned within the top third of the sampler)

Twenty three sites were installed in order to provide suitable spatial coverage of the area (Figure 8.5). The majority of the sites were located along the northern boundary with the residential area and within the Mount industrial area itself. Several sites were positioned in the Sulphur Point area in response to complaints by business. Three sites were positioned in the northern section with two within the open coast back beach system. One was located further to the east nearby State Highway 2 which was intended to provide a profile for predominantly roadway particles.

The adhesive strips were initially tested in a pilot programme (in Whakatāne) to determine the length of time for which they would remain sticky. Weather conditions played a role in determining this critical time, with damp, humid conditions reducing the adhesive durability. A suitable exposure time of approximately one week was determined for the sampling programme which also provided a workable timeframe for exposing and exchanging samplers.

⁷⁰ Datson, H. & William, J. 2007, The development of a novel method for directional dust monitoring, *Environ Monit. Assess.* 124:301–308, DOI 10.1007/s10661-006-9227-4.



Figure 8.5 Directional dust sampler site locations

The field sampling period was from 13 August to 3 December 2008. The wind patterns for this period were as shown in Figure 8.2. Winds were common in a clockwise arc from SW to NE. The northerly component is typical during this time of the year as the sea breeze process develops most days from late morning throughout the afternoon. Predominant (and also the strongest) wind was from the W to SW quadrant. The diurnal pattern (Figure 8.3) is also very typical for such a coastal location; with increases in wind speed recorded from approximately 9 am as solar heating develops temperature and pressure differentials, across the open coast boundary.

Following the one week exposure the adhesive strips were removed. These were mounted on a clear A4 film (Figure 8.6), catalogued and grayscale scanned at 1200 dpi. The scanned image background was white, but trials were also undertaken with a black background, with the image then being inverted in Photoshop. This gave a better representation of the lighter coloured and clear fraction of particles, but because the investigation was looking at dust nuisance the former approach of a white background was employed.

The scanned image was given a unique name and opened in Photoshop CS3. A Photoshop “action” (macro) had been designed to then select, based on direction and save the sample film for each of the eight wind direction bins (N, NE, E .etc) into a separate jpeg file (Figure 8.7).

It should be noted that due to the adhesive mechanism used to mount the film on the sampler the northern quadrant was not always able to be fully analysed, and in these instances a smaller unaffected portion was selected for analysis.



Figure 8.6 Example of several exposed adhesive collection film

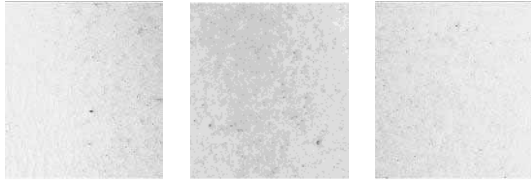

Figure 8.7 Example of original exposed adhesive collection film and then the segmented areas based on direction

Each direction file was analysed by the ImageJ software and image size, number of particles and particle area coverage was determined (Figure 8.8). A percentage coverage figure was finally calculated and used as the measure of dustiness for each of the eight wind direction bins (Table 8.1). The level of dustiness has also been described as the effective area coverage (EAC)⁷¹ and will be used to describe this characteristic from this point forward.

Radar plots were used to graphically represent the data for each one week sampling period.

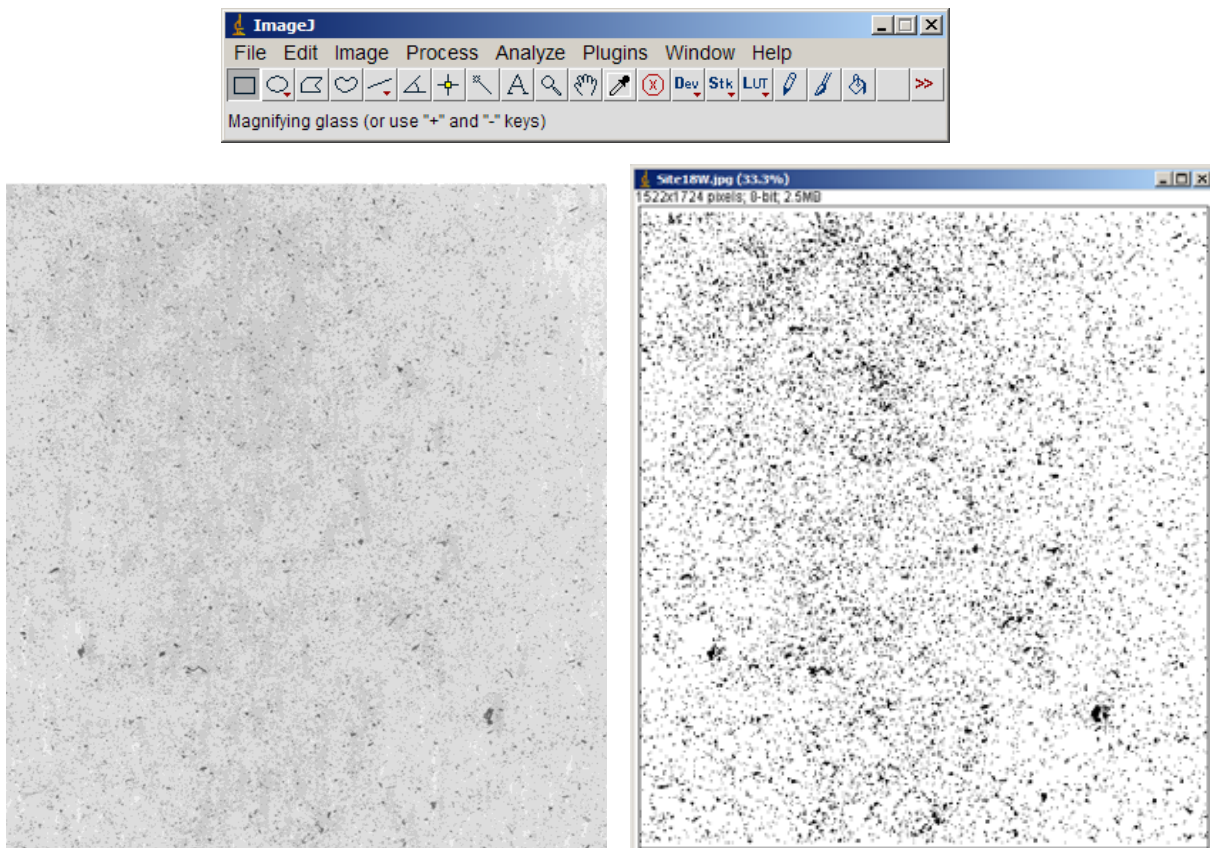

Figure 8.8 Direction section and the Image J output

⁷¹ Hancock, R. et al., 1976, *Visual Response to Dustiness*, Journal of the Air Pollution Control Association, Volume 26, No. 1, 4p.

Sea spray was present on all of the films. These particles were typically only several microns or less, and the colouration was typically clear. For the purposes of the investigation into nuisance dust, these particles were not examined further in relation to contributing to the EAC.

Salt particle



Elemental spectrum

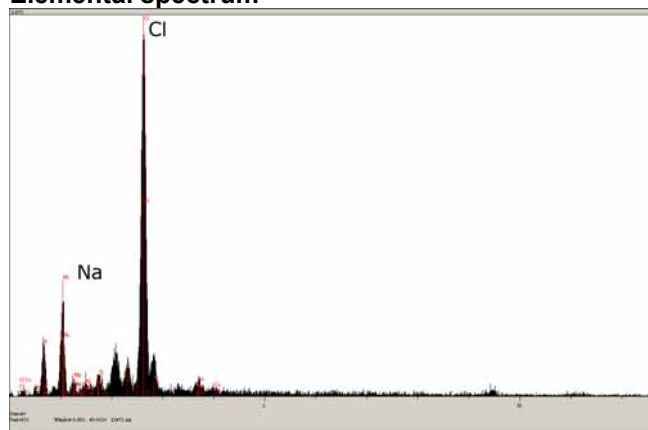

Figure 8.9 Collected salt particle and associated SEM elemental spectrum

Table 8.1 Percent coverage calculation based on ImageJ outputs

Film number	Direction bin	Start date	End date	Image size (pixels ²)	Number of particles	Particle coverage (pixels ²)	% coverage
18	N	1/10/08	8/10/08	1112640	360	2528	0.23
18	NE	1/10/08	8/10/08	2623928	348	1675	0.06
18	E	1/10/08	8/10/08	2623928	621	2885	0.11
18	SE	1/10/08	8/10/08	2623928	704	3329	0.13
18	S	1/10/08	8/10/08	2623928	1998	15518	0.59
18	SW	1/10/08	8/10/08	2623928	9432	112150	4.27
18	W	1/10/08	8/10/08	2623928	20092	311935	11.89
18	NW	1/10/08	8/10/08	2623928	5426	56735	2.16

Bubble plots have been used to deal with the temporal display issues and for each site give a succinct summary of effective area coverage on a wind direction basis over time. From these plots it is easy to determine the direction associated with dominant particle supply and deposition. The display method also allows for a quick check against potential source activity data for a given weekly period.

8.1.3 Results

A small selection of the bubble plots is presented in Figure 8.10. Site 19 is in the back dune coastal area seaward of Marine Parade, while sites 4 and 18 are located along Totara Street. A full presentation of the bubble plots for all sites is shown in Figure 8.11. When looking at these plots the standouts in terms of high EAC are Sites 4 and 18. An example of the level of deposition can be seen in the extracted scanned sections from tapes collected at Site 18 (Figure 8.13). Towards the end of the sampling programme Sites 21 and 24 also recorded some elevated results. For Site 21 the adjacent property was undergoing development, (this is discussed in Section 8.2), while agricultural activities were noted in the adjacent paddocks to the north of site 24.

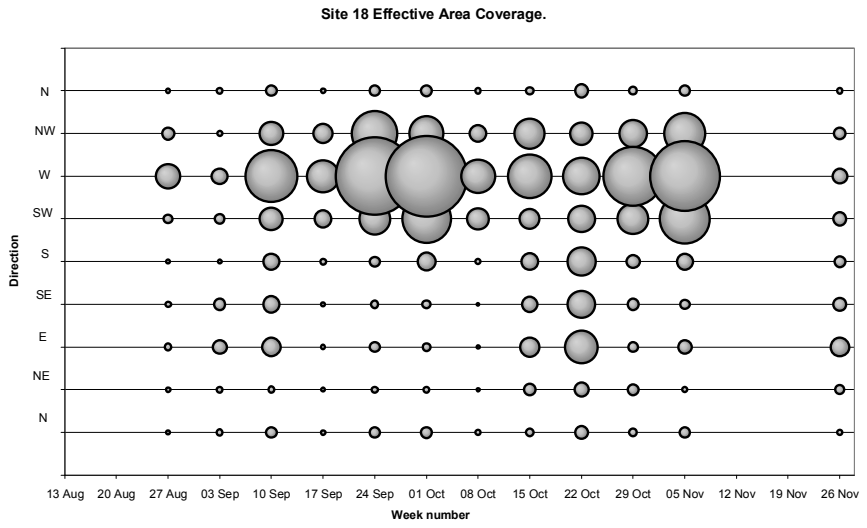
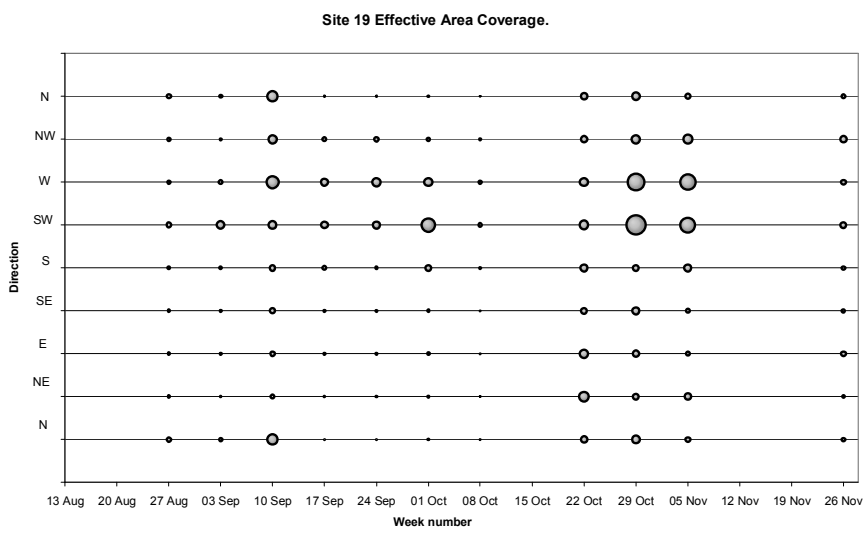
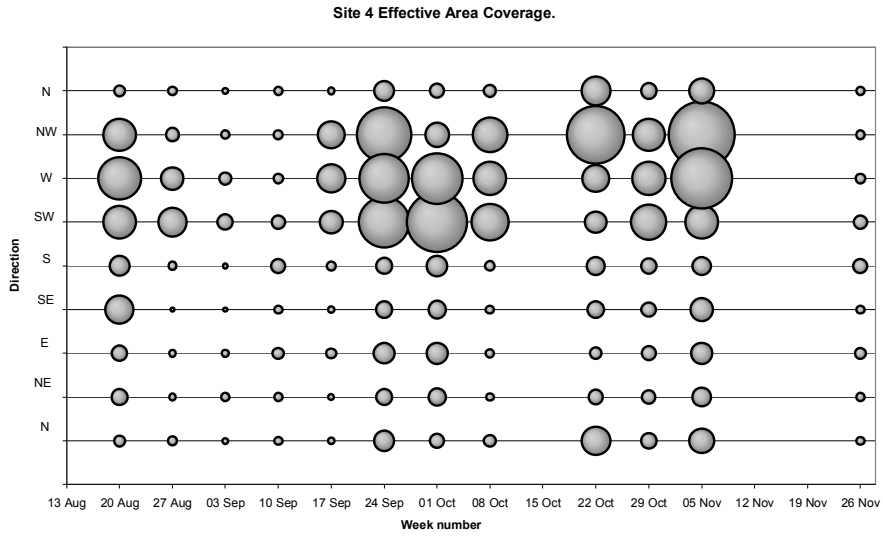

Figure 8.10 EAC bubble plots incorporating monitoring period and direction

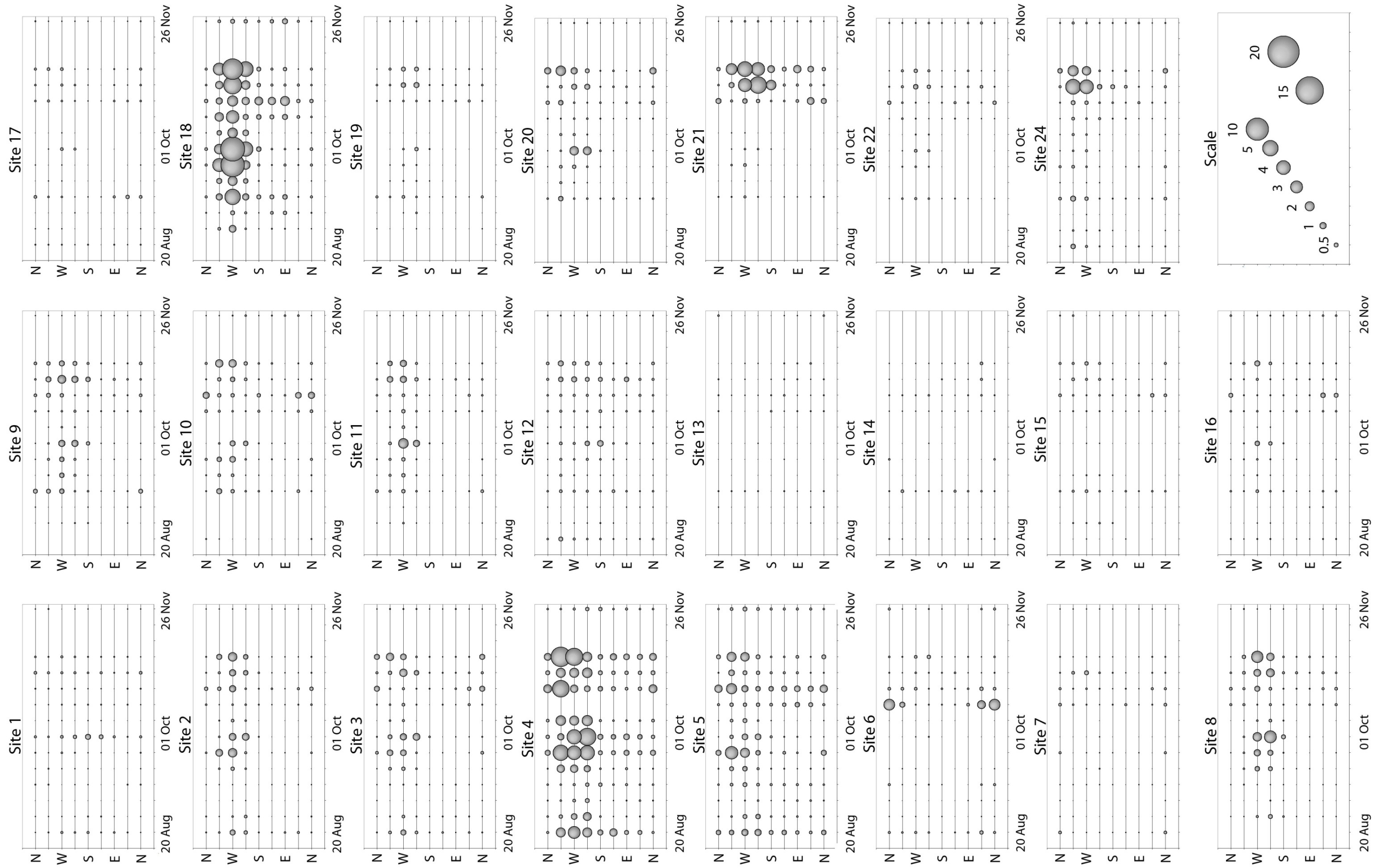

Figure 8.11 EAC plots for entire monitoring period

The films collected in the week following 1/10/2008 (Figure 8.11) showed the effects of a palm kernel episode which was detected right across the Mount area being monitored.

A second period for the week beginning 5 November 2008 also had a considerable amount of palm kernel collected at sites 4 and 18.

SEM analysis at peak sites

Two sites were chosen for further SEM analysis. Site 4 (corner Triton Ave and Totara Street) for the period 5-12 November 2008 and Site 6 (Tauranga Bridge marina) for the period of 15-22 October 2008. These sample films were chosen as they showed higher EAC values.

Site 6 – this sample was collected during a period where northerly winds were common. The sample showed a dominance of cenospheres which when viewed with the naked eye gave the northern sectors of the sample film a grey appearance. These cenospheres ranged in size from 20 to 100 μm . Other particles consisted of palm kernel, pine pollen and salt crystals, although these are all minor contributors for this sample.

Site 4 – this sample was taken from the western sector of the sample film which faces Totara Street and the Port of Tauranga Ltd wharves. The particle profile was heterogeneous with particle sizes ranging from $\sim 10 \mu\text{m}$ to several hundred microns. Palm kernel particles were represented, and were easily detected based on their fibrous appearance. Six particles were chosen for elemental analysis; C and O were the primary peaks for the palm kernel while Si, Al and Mg were the dominant and common peaks for the other chosen particles.

SEM analysis at sites close to coal transfer facility

A number of complainants have identified the coal transfer facility as the potential source of the nuisance dust experienced at their property. Several monitoring sites (8, 9 and 12) were located to determine the amount of the dust that could be attributed to the coal transfer operation. These sites were located with a particular focus on the storage shed, the conveyors that run along Totara Street Port boundary and the hoppers for loading the train carriages. The earlier part of the transfer process (unloading vessels and transfer to storage shed) would also be indirectly monitored by these sites based on prevailing winds and complainant locations.

The bubble plots shown in Figure 8.12, particularly for sites 8 and 9, show a pattern of elevated EAC from the west/southwest quadrant, this aligns well with the coal transfer activities but also the other general port activities may be responsible for these higher values. Visual checking of particle type using the stereo microscope was then undertaken for each period of sampling for this quadrant of interest (Table 8.2). It should be noted that Site 18 recorded low EAC's for wind directions from the north which would theoretically transport any material from the facility to this monitoring site.

Site 8 Effective Area Coverage.

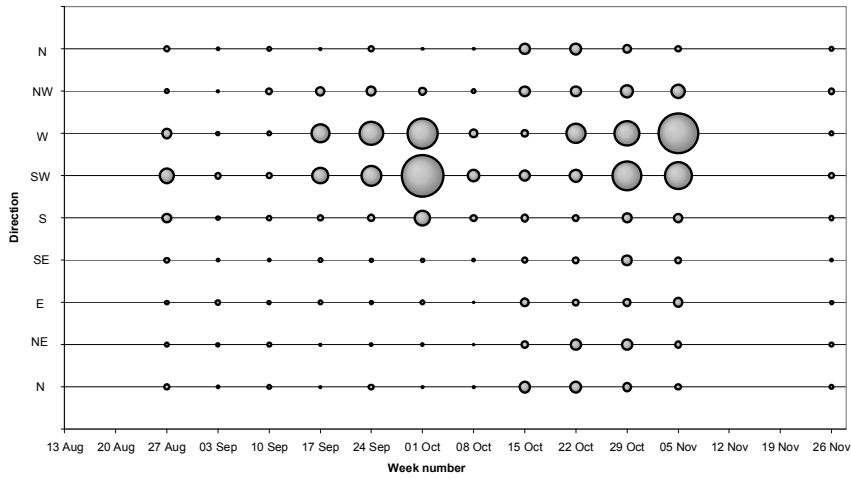

Site 9 Effective Area Coverage.

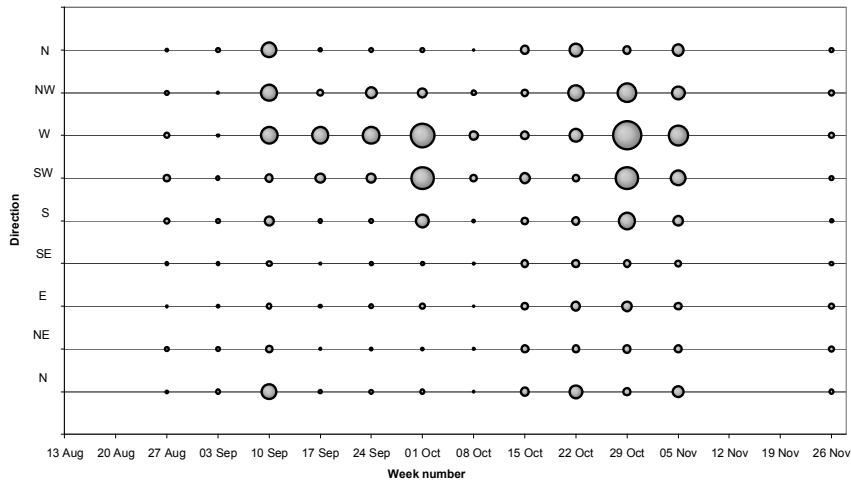

Site 12 Effective Area Coverage.

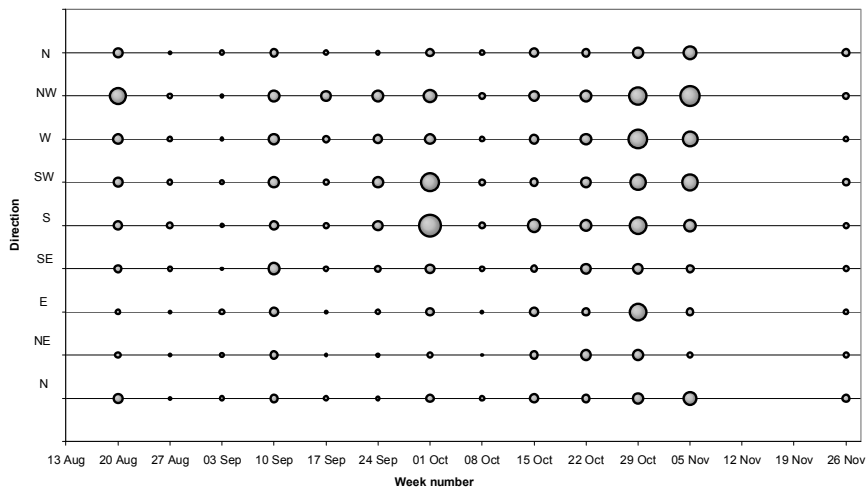

Figure 8.12 Selection of bubble plots for sites of interest.

Table 8.2 provides a brief description of the particle characteristics for each sampling period for Sites 8, 9 and 12 (Figure 8.12) of the western quadrant of the film.

Table 8.2 Description of particles and activities for Sites 8, 9 and 12.

Sampling period start date	Site	Average EAC	Coal present (y/n)	Approximate % of coal type particles	~Size range (µm)	Other particles present*	Pine pollen present	Coal ship unloading ⁷²	Coal train loading ⁷²
20/8/08	8		Y	5	<200	Soil, tyre, cenospheres, fern pollen.	Y	N	10 trains
	9		N	-	<300	Soil, tyre, cenospheres.			
	12		N	-	<300	Soil, tyre, cenospheres.			
27/8/08	8		Y	10	<400	Combustion fragments, tyre wear, soil and coastal particles.	Y	N	6 trains
	9		Y	5	<200	Tyre wear, soil and coastal particles.			
	12		N	-	<100	Tyre wear, soil and coastal particles, fibres.	N		
3/9/08	8		N		<200	Combustion fragments, soil and coastal particles.	N	N	N
	9		N		<100	Combustion fragments, soil and coastal particles.			
	12		N		<100	Fabric fibres, soil and coastal particles, rust particles.			
10/9/08	8		Y	10	<200	Palm kernel, tyre wear, soil and coastal particles.	Y	Y (10/9 to 11/9)	13 trains
	9		Y	5	<1000	Soil and coastal particles, insect fragments, paint fragments, combustion fragments.			
	12		N	-	<200	Soil and coastal particles, combustion fragments.			
17/9/08	8		N	-	<300	Soil and coastal particles, cenospheres, tyre wear, combustion fragments.	Y	Y (21/9 to 24/9)	13 trains
	9		N	-	<300	Soil and coastal particles, cenospheres, tyre wear, combustion fragments.			
	12		N	-	<300	Soil and coastal particles, cenospheres, tyre wear.			
24/9/08	8		Y	20	<200	Tyre wear, cenosphere, fern pollen.	Y	N	12 trains
	9		Y	15	<200	Tyre wear, cenosphere, soil particles, combustion fragments.			
	12		Y	5	<200	Tyre wear, coastal/soil particles, combustion fragments.			
1/10/08	8		Y	50	<400	Cenospheres, paint fragments, soil/coastal particles, palm kernel, tyre wear.	Y	N	12 trains
	9		Y	30	<600	Soil/coastal particles, palm kernel, tyre wear.			
	12		Y	5	<200	Soil particles, palm kernel, tyre wear.			

⁷² Sourced from Port of Tauranga records.

Sampling period start date	Site	Average EAC	Coal present (y/n)	Approximate % of coal type particles	~Size range (µm)	Other particles present*	Pine pollen present	Coal ship unloading ⁷²	Coal train loading ⁷²
8/10/08	8		Y	10	<200	Insect parts, sporangia, tyre wear, cenospheres, palm kernel, soil particles.	Y	N	13 trains
	9		Y	5	<150	Quartz, combustion fragments, tyre wear, soil particles.			
	12		N	-	<1000	Rust particles, soil particles.			
15/10/08	8		Y	5	<250	Soil/ coastal particles, tyre.	Y (but less than previous week)	Y (15/10 to 17/10)	9 trains
	9		Y	5	<800	Quartz, combustion fragments, tyre wear, soil particles.			
	12		N	-	<200	Palm kernel, insect parts, rust particles, soil particles.			
22/10/08	8		Y	20	<200	Soil/coastal particles, tyre wear, combustion fragments.	Y (but few)	N	8 trains
	9		Y	10	<200	Soil/coastal particles, tyre wear, combustion fragments, rust particles.			
	12		N	-	<200	Soil/coastal particles, tyre wear, rust particles.			
29/10/08	8		Y	40	20 – 300	Palm kernel, cenosphere, tyre wear, coastal particles (quartz)	Y	N	4 trains
	9		Y	20	20 - 300	Palm kernel, cenosphere, tyre wear, soil and coastal particles (quartz).			
	12		N	-		Palm kernel, cenosphere, tyre wear, soil and coastal particles (quartz), paint fragments, 1mm rust fragments.			
5/11/08	8		Y	40	<300	Soil/coastal particles, tyre wear, combustion fragments, cenospheres.	N	Y (7/11 to 9/11)	5 trains
	9		Y	10	<400	Soil/coastal particles, tyre wear, combustion fragments.			
	12		N	-	<300	Soil/coastal particles, tyre wear.			
26/11/08	8		Y	5	<100	Soil/coastal particles, tyre wear, combustion fragments, cenospheres.	N	N	13 trains
	9		Y	5	<100	Soil/coastal particles, tyre wear, combustion fragments, cenospheres.			
	12		N	-	<300	Soil/coastal particles, tyre wear, combustion fragments, cenospheres, palm kernel.			

* All samples have sea salt particles present.







	0.05
	0.1
	0.2
	0.5
	1
	3
	6
	9
	12

Figure 8.13 Examples of EAC's from collected samples from Site 18

8.2 Samples next to a development site, 2008

Samples were collected next to a site where development/construction was occurring (Figure 8.14). The site was located to the east of the Aerodrome Road/Jean Batten Drive roundabout.

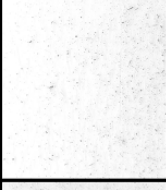
Results from this period of collection show how good site management in relation to nuisance dust potential is important when areas are being developed, particularly due to the light characteristics of the soil within the Mount Maunganui area.

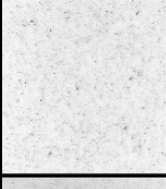
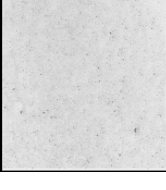
Building site



Sample from building site surface

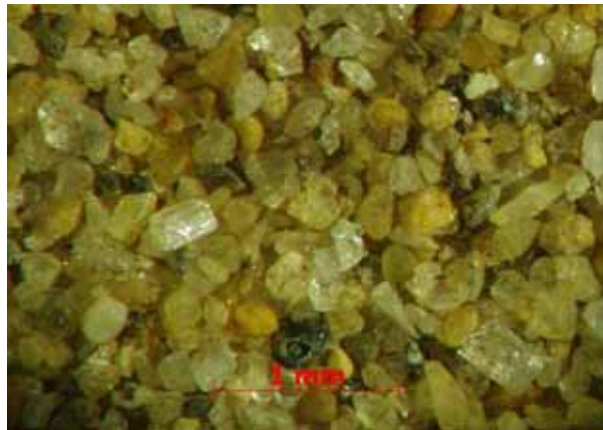

Mag. 20 x and 66 x. Note sample is on black background

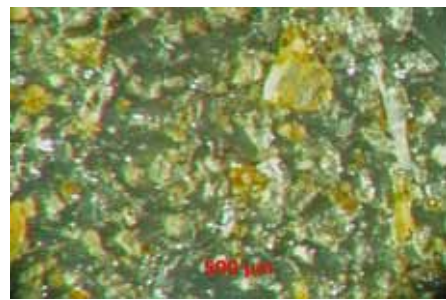
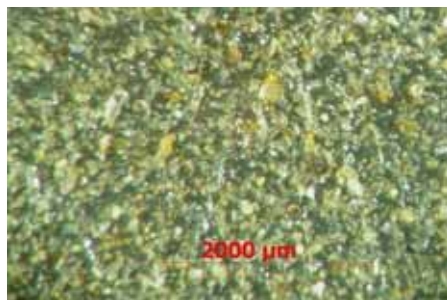

Sample collected during development



Figure 8.14 Sample collected from adjacent to active building site

8.3 Directional dust detector programme summary

The directional dust detector programme was setup to gain a better understanding of the spatial distribution and quantity of the nuisance dust experienced within the Mount Maunganui/Sulphur Point area. Several novel approaches were used to display the processed data (Figure 8.11 and the plots in Appendix 5). Where necessary, further SEM analysis was also performed on samples from several of the peak sites and also from the sites adjacent to the coal transfer facility.

The spatial analysis showed that the highest EAC values (average and maximum) were recorded at the sites on the western port boundary at Mount Maunganui. These values typically decreased when moving to the east and north east towards the residential areas.

Common wind patterns for the 13 weeks of sampling were those from the south west and west quarters (which is the prevailing wind). As a result of this general wind pattern EAC values were typically low for the Sulphur Point area. Several of the weeks did have periods of strong easterlies (03 September 2008, 08 October 2008, 22 October 2008 and 5 November 2008) but these failed to register as elevated values of average or maximum EAC.

Overall the results for the period of monitoring show that all sites experience some levels of dust deposition which is as expected for an urban area of this type. At some of the sites the levels are somewhat elevated due to the proximity of sources. The source profile for Mount Maunganui is complex with analysis results showing a strong natural particle signature (from open coast/harbour beaches, exposed tidal flats, and pollen from a range of sources (Matakana pine pollen is well represented). This natural signature is complemented by a range of activities in and around the port area (see plots of average and maximum EAC plots in Appendix 5). This is not surprising due to the volume of product moving through this area and should be closely monitored by relevant council staff to ensure dust management plans and yard good practice are being implemented and working effectively.

Part 9: Industrial stack emissions

Industrial stack emissions have also been highlighted by complainants as a potential source of nuisance dust. An investigation of some of the more significant stack sources was carried out in 2011/2012 and the results were assessed by an independent reviewer. The assessment involved audit stack testing of each of the sources (for comparison against the emission limits given in the air discharge consents) and collection of additional 'grab' samples from each stack for analysis by SEM.

A copy of the independent review report is given in Appendix 7, but for convenience the conclusions of that report are reproduced below:

"The stack samples have provided useful information on the types of particles that could be expected from some of the industrial sources in Mt Maunganui. Some of the particles are quite unique (eg. the semi-crystalline materials found at NZ Marine Services and Lawter (NZ) Ltd), and would be easily identified in samples of fallout. Other particles also have a unique appearance (eg. cenospheres) but can be produced by a number of different sources. However, there are also particles that would be difficult to distinguish from those commonly found in most urban environments (eg. cement dust, and aggregate dust from asphalt plants).

"The main aim in collecting these samples was to support the earlier work on deposited dust samples, through possibly identifying particular causes of the dust fallout. However, it was noted in the earlier report (as attached to this report) that the particles found in the dust deposits were typical of general urban dust. And:

No individual types of particles were especially dominant in any of the samples, which indicates the lack of any major contribution from a specific source or sources.

"The lack of any dominant particles in the deposition samples clearly indicates that there is no one single source causing these fallout problems. Rather, they are most likely the result of general accumulations of dust as a result of contributions from the numerous possible sources in the Mt Maunganui urban area. These sources would include natural releases of airborne matter (soil, vegetation and sea spray), domestic activities (cooking, heating, gardening and rubbish burning), commercial activities (cooking, heating, gardening and construction), transportation (cars, buses, trucks, trains and ships) and industry. These releases can occur on an almost continuous basis, but their impacts are likely to be more episodic in nature, due to variations in weather conditions, especially rainfall, and wind speed and direction."

Part 10: Summary and Conclusions

The environmental impacts of dust emissions can cause widespread public concern about environmental degradation and/or a decline in amenity. The nature and extent of the problem and significance of the effects usually depend on the nature of the source, sensitivity of the receiving environment and on individual perceptions.

A number of complaints have arisen in the Mount Maunganui and Sulphur Point areas. Complainants raised a number of potential sources but intermittent depositing and a range of physical characteristics exhibited by the collected samples resulted in a situation where accurate source identification was problematic.

In order to gain a better understanding of nuisance dust in the Mount Maunganui area several paths of investigation were undertaken:

- Grab sample collection was undertaken over a period of time by council staff at a range of locations based on complaints and highlighted issues.
- A detailed depositional dust monitoring programme was undertaken in the Mount Maunganui and Sulphur Point areas.
- A continuous particulate (PM₁₀) monitoring instrument was installed at the Council's Totara Street air quality monitoring station.

10.1 Background information

Dust particle size is an important factor in determining the way in which the dust moves through the air. It is also relevant for the possible environmental impacts, especially health effects. Particle sizes are normally measured in microns, and the size range of airborne particles is typically from less than 0.1 microns up to about 500 microns, or half a millimetre.

When dust particles are released into the air they tend to fall back to ground at a rate proportional to their size. Any particles 100 microns in size will take just over two seconds to fall to the ground, while those 10 microns in size will take more than 200 seconds. In a 20 kph wind, the 100-micron particles would only be blown about 10 metres away from the source while the 10-micron particles have the potential to travel about a kilometre (fall times and travel distances depend on the release height).

Human health effects of airborne dust are mainly associated with particles less than about 10 microns in size (PM₁₀) (Figure 2.2), which is small enough to be inhaled (Figure 2.3). Nuisance effects can be caused by particles of any size, but are most commonly associated with those larger than 20 microns.

The area of interest for this investigation has experienced significant growth in the last two decades, and data shows that Tauranga is now New Zealand's ninth largest Local Authority in terms of population. From the 2006 census the population of Tauranga City was 103,635, which is a 14% increase over the 2001 Census figure of 90,912. This increase is significantly higher than the nation-wide growth rate of 7.8% over the same period.

At present there is approximately 865 hectares of industrial business zoned land within Tauranga City in eight general localities. For the Mount Maunganui area the percentage of vacant land has reduced dramatically from 52% in 1982 to 11% in 2009.

Within this industrial zoned land a total of 26 businesses undertake activities that require an air discharge consent. Discharge contaminants include both gases and particles. The particle size distribution for these activities will be varied with finer particles typically associated with the combustion related processes. Coarser material will be associated with (but not limited to) panel beating activities although the consents for these businesses are primarily directed at fume emissions from the painting operations. There may also be contributions from other non-consented activities such as vehicle workshops, metal fabrication and finishing, scrap metal processing, joinery factories, bakeries, and wood carving.

For consents where dust generation potential exists there is normally a standard condition which relates to management of this dust in order to ensure there are no adverse effects experienced beyond the boundary. This requirement also applies to non-consented (permitted) activities.

10.2 Meteorological conditions

This investigation not only looked at the activities within the area but also summarised the wind climate generally, and also for shorter periods related to complaints. This natural driver is very important when discussing air quality. A summary of a period of record from the Tauranga Aero meteorological site shows the effect of seasonal patterns. This will change the natural PM₁₀ composition (such as an increase in sea borne particulate) impacting on the area. A dominant SW quadrant contribution in the annual wind rose will result in material being transported through the industrial area and impacting on the residential zone to the northeast of the industrial area. Winds from the easterly quadrant are less common but can often be gusty as these winds can be associated with depressions positioned to the north and accompanying stronger pressure gradients. Onshore sea breezes are prevalent during the summer months. Calm conditions contribute less than 5% at this site.

Rainfall also has the ability to affect air quality, and for the Mount Maunganui area rainfall occurs on average 150 days of the year. This precipitation, through the process of wet deposition, scavenges particles when falling rain droplets and the particles collide (washout). Due to the varying scale of this process it is difficult to quantify the effect of localised precipitation on dust particles but it is recognised that it occurs. Evidence of this process has been shown to occur from dust investigation work undertaken at the Ngapuna Industrial area in Rotorua.

10.3 Other relevant factors

While wind and rainfall are important controllers of the quality of air within the area, the type of land surface is also significant. Large areas are now sealed or covered with buildings, but where development occurs or where vegetative cover is reduced the underlying soil type can also be a factor on air quality, especially during the hotter summer months. Three types of soil are present in the industrial area, (i) Anthropogenic soils (man-made (Mm) are present throughout, (ii) Oe (Ohope Series) is present along with Mm in a zone north of a line extending from the Ballance Agri-Nutrients Ltd fertiliser works to Portside Drive, (iii) Ki (Kairua Series) is found along with Mm in the zone south of this line, back towards Te Ngaiopapapa Point. All three soils are well drained and are of an aeolian sand parent material origin. Physical characteristics of these soils make them highly susceptible to wind erosion once any vegetative cover is removed.

Pollen is often linked with air quality issues within the region particularly in relation to the percentage of population that suffers from allergic reactions. The Mount Maunganui area does not escape from this widely felt phenomenon. *Pinus radiata* (pine) pollen (e.g. from but not limited to plantations on Matakana Island) is typically the first to appear each year (~July/August), followed by deciduous trees, including poplars, oaks, elms and hazelnuts, followed by the grass pollen season that normally lasts until Christmas.

10.4 **Complaints data**

With an understanding of the drivers both natural and anthropogenic it was also useful to see how the dust complaints within the area have tracked overtime. The BOPRC complaints database shows an increase in complaints in the 2004/2005 period. This coincides with the operational start of the purpose built Port of Tauranga coal transit and storage facility, which receives and stores up to two shipments (70,000 tonnes) of coal, before trans-shipping to Huntly by rail. It was also at a time when there were on-going operational issues at a nearby composting operation. The figures for 2011 shows a reduction from the annual average (2000 to 2010) of 37 complaints (24 minimum, 65 maximum) to 16 dust complaints for 2011.

10.5 **Air monitoring data**

The pattern of air quality over time can also be checked by looking at historical monitoring. A range of relevant air quality monitoring has been undertaken in the Mount Maunganui area. Particulate (TSP and PM₁₀) monitoring was undertaken in 2001 and 2003. The 2001 projects were investigating complaints associated with fertiliser storage and handling and timber processing activities. The 2003 monitoring was associated with the NERMN programme and was located on the Tauranga City side of the bridge focusing on particulate contributions from vehicular sources. A range of gas contaminant sampling has also been undertaken, once again focussing on particular industrial activities. No dedicated long term TSP (dust) or PM₁₀ monitoring programme has been undertaken to date, and due to the spatial variation of the issue it would be challenging (financially and operationally) to cover the area adequately.

10.6 **Dust complaint investigations**

The Bay of Plenty Regional Council has undertaken a number of investigations (a collection of 30+ grab sample sites) in relation to concerns expressed by members of the public in relation to dust nuisance in the Mount Maunganui and Sulphur Point areas. The sampling for these investigations involved a grab sample methodology. This type of sampling involves the collection of deposited material by adhesive tape or brush to pottle. Both methods have their advantages and a combination of both for each sample site is the preference. Notation of exposure period and prevailing meteorology during deposition adds value to the sample analysis. Other observations such as atypical adjacent activities are also valuable. Sample locations included residential properties commercial and industrial premises, marinas, roadways, open coast and harbour beaches and Port of Tauranga areas.

The particles seen in Pilot Bay beach and open coast beach east of Moturiki Island grab samples typically make up the base particle profile for many of the samples collected and reported on in the grab sample and other sections of this report. The difference between these reference samples and the complainants' samples being particle size, with the complainants' samples showing a finer fraction version of the beach particle profiles.

However for the majority of the grab samples the particle profile was one of a heterogeneous nature. To the naked eye the collected material often had a dark grey to blackish colouration but under the optical microscope the samples were non-uniform in colour characteristic.

This heterogeneous mixture of particles consisted of soil particles and those of a coastal origin, together with anthropogenic particles such as those from tyre wear which were the most common. Particles from particular types of combustion, such as cenospheres from shipping emissions, a range of fibres, as well as a seasonally present selection of pollens and other biological matter such as sporangia were also present. Around certain areas and particular activities paint globules and fragments were present in the samples. Woody material was also detected in some samples in close proximity to handling areas at the port.

The base and majority of most of the complainants' samples would be defined as typical urban dust, however due to the elevated level of activity, such as volumes of vehicular transport and port (and related) activities in the area, the quantities are often enhanced to a point where they become a regular visual nuisance if meteorological conditions are conducive.

The particulate profiles for a selection of three locations elsewhere within the region (Whakatāne, Te Puke and Rotorua) showed similarities in appearance and composition to those collected in Mount Maunganui although deposited quantities were less. The dark particles were dominant and consisted of tyre wear particles, some soil particles and for the Whakatāne site at this time of the year (in winter), some particles from domestic heating sources. The SEM output for the selection of particles collected at all sites showed a pattern typical of general urban dust.

10.7 Visual impact monitoring

In order to gain a better understanding of the spatial distribution and quantities of nuisance dust experienced within the Mount Maunganui/Sulphur Point area a monitoring programme was devised in late 2008.

The field equipment for this programme was based on the technique of Datson & William (2007). The field sampler consisted of a transparent adhesive film wrapped around a vertically mounted rain protected cylinder with true north marked (for alignment, repeatability and analysis)

Twenty three sites were installed in order to provide suitable spatial coverage of the area. The majority of the sites were located along the northern boundary with the residential area and within the Mount industrial area itself. Several sites were positioned in the Sulphur Point area in response to complaints by local businesses. Three sites were positioned in the northern section with two within the open coast back beach system. One was located further to the east nearby State Highway 2 which was intended to provide a profile for predominantly roadway particles.

The results for the period of monitoring (20th August 2008 to 3rd December 2008) showed that all monitoring sites experienced some levels of dust deposition which was as expected for an urban area. At some of the sites the levels were somewhat elevated due to the proximity of sources. The source profile for Mount Maunganui was complex with results showing a strong natural particle signature (from open coast/harbour beaches, exposed tidal flats, pollen from a range of sources (Matakana pine pollen was well represented)). This natural signature was significantly complemented and often modified by particles from a range of activities in and around the port area. This was not surprising due to the levels of activity (general traffic volumes and port (and related) activity) in this area.

Recent discussion with a Port of Tauranga representative⁷³ highlighted a number of initiatives from recent and proposed sealing of loose surface areas on both the Mount Maunganui and Sulphur Point sides of the operation (totalling nearly 74,000m²), sprinkler installation on large sand stockpiles, storage of palm kernel in the coal storage facility, and the installation of wind fencing around areas of log storage.

10.8 Conclusions

10.8.1 Key Points

- 1 Various ambient dust monitoring studies from 2000 to 2010 have shown only two 24-hour results above the recommended nuisance level of 80 µg/m³. Overall, the levels of suspended particulate matter are quite acceptable for an urban area, although moderately higher than levels recorded in other less developed parts of the region.
- 2 More than 30 grab samples have been examined over the last 6 years to assist investigations into dust nuisance effects. Of these four samples provided clear evidence of dust impacts from the coal handling facilities at the Port. However, these samples all preceded the improvements made to the coal handling equipment in mid-2006. Coal dust was identified in two other samples subsequent to that time but it was considered that the port facility was an unlikely source because of the significant separation distances to the complainants' properties.
- 3 Significant amounts of palm kernel dust was identified in six grab samples, since then the handling and storage practices of this material has been modified by the Port of Tauranga.
- 4 Wood and bark material was found in six of the grab samples. Significant amounts were often present in the collected samples (see Section 6.15). On-going sealing of log storage areas in and around the port and improved yard management will see reductions in material from these potential sources.
- 5 All other grab samples were found to contain various mixtures of typical urban dust particles, including soil and sand, tyre wear, cenospheres and other combustion-related materials, pollens and other plant matter, man-made fibres, paint flakes and particles, rust flakes and possibly welding residues.

⁷³ Pers. Comms. Rowan Johnstone, Port of Tauranga, 22 February 2012.

- 6 The analysis of the grab samples was supported by a visual impact monitoring programme carried out from August to December 2008. The results from this showed that the greatest dust impacts were shown to occur at sites closest to the main port area at Mount Maunganui. Much of the dust impacts were attributed to the same general materials as noted in point 5 above. However, a few of the samples collected downwind of specific locations (Sites 4, 5 and 18) showed clear evidence of impacts due to palm kernel and log handling activities.
- 7 Finally, samples of particulate emissions were collected from six industrial sites identified as having the greatest potential for off-site impacts. Some of the particles were found to be quite unique, and would be easily identified in samples of fallout. Other particles also had a unique appearance (eg. cenospheres) but could be produced by a number of different sources. However, there were also particles that would be difficult to distinguish from those commonly found in most urban environments (eg. cement dust, and aggregate dust from asphalt plants).

Overall the results of this report show that the Mount Maunganui and Sulphur Point areas can experience elevated levels of nuisance dust and particular dust events when certain meteorological conditions exist. The heterogeneous particle composition of most of the dust does not point to any one particular industrial operation, but rather to a range of contributing sources. The port operation in the centre of the area of interest undertakes a number of activities which can result in issues offsite if not well managed, as shown in a few of the grab samples and the directional dust detector programme results. Activities such as volumes of heavy traffic supporting the operation of the port, commercial and industrial activities can also contribute to elevated levels of dust. Sweeping frequency and best practice yard management should be regularly reviewed for operations within this area to ensure offsite effects are minimised.

Appendices

Appendix 1 – Soil parameters and descriptors particle size

ϕ scale	size range	Wentworth range	name
-1 to -2	2–4 mm	0.079–0.157 in	very fine gravel
0 to -1	1–2 mm	0.039–0.079 in	very coarse sand
1 to 0	0.5–1 mm	0.020–0.039 in	coarse sand
2 to 1	0.25–0.5 mm	0.010–0.020 in	medium sand
3 to 2	125–250 μm	0.0049–0.010 in	fine sand
4 to 3	62.5–125 μm	0.0025–0.0049 in	very fine sand
8 to 4	3.9–62.5 μm	0.00015–0.0025 in	silt
∞ to 8	$1/\infty$ –3.9 μm	$1/\infty$ –0.00015 in	clay
∞ to 10	$1/\infty$ –1 μm	$1/\infty$ –0.000039 in	colloid

.

Appendix 2 – Graham Environmental Limited – Mount Maunganui dust



2 Blumhardt Place
Avondale
P O Box 19-691
Avondale
Auckland 1746
New Zealand

24 July, 2006

Environment BOP
P O Box 364
Whakatāne

Attention: Steve Pickles

Mount Maunganui Dust Samples

As requested, the following notes provide an assessment of the dust samples collected by Kelly Baxter from several sites in Mount Maunganui. This is based on my examination of the photomicrographs taken by Shane Iremonger.

Balcony Sample from 32 Miro Street (13 June, 2006)

The photomicrographs showed a mixture of black, grey, brown and white irregular shaped particles, which indicates a mixture of general urban dust and coal dust. At a very rough estimate, the coal dust particles make up at least 30% of the total. The identification of the coal dust particles is supported by the similarity with those shown in the photomicrographs of the dust sample collected from a coal shed at the port.

The coal dust particles in the Miro Street sample ranged in size from between about 10 and 100 microns. There were also particles smaller than 10 microns, but it is difficult to identify these as being coal or other materials, at the magnification used for the photos.

The presence of particles up to 100 microns in size indicates that this portion of the dust was most likely generated within 100 to 200 metres of the affected property, although greater travel distances are possible under high wind conditions. In addition, the smaller particles may be carried over much greater distances.

Window Sill Samples, 47 Tawa Street (24 May and 14 June, 2006)

The photomicrographs for both samples showed a mixture of grey, brown and white particles, as expected for general urban dust, and a small proportion (<10%) of black particles. There was also a similar proportion of red-brown fibrous particles, most likely wood or bark.

Most of the particles in the Tawa Street samples were less than about 20 microns, although there were a few larger than this, up to about 100 microns.

Conclusion

The photomicrographs indicate that the properties in Miro and Tawa Streets are both being affected by coal dust, and the most likely source of this fallout is the coal handling facilities at the port, immediately adjacent to Totara Street.

Yours sincerely

A handwritten signature in black ink, appearing to be 'BG', with a long horizontal line extending to the right.

Bruce Graham

Appendix 3 – Flow chart showing coal discharge from ship to shed then onto train



Coal unloaded from ship using cranes and grabs



Grabs discharge into hoppers then into trucks



Trucks drive to “dump pit” discharge to underground hoppers then conveyed to shed



Conveyer to shed



Conveyer to shed



Coal put into hoppers, conveyed to silos



Conveyer from shed



Conveyer to silos



Conveyer to silos



Silos discharge to train carriages

Appendix 4 – Directional Dust Sampler

FILE NOTE

File Note From: Shane Iremonger

File Reference: 5180 09

Date: 23 July 2008

Subject: Directional Dust Detector (D³)

1 **Sampler (D³) construction**

The sampler (Figure 1) consists of the following items:

- PVC tube 80 mm diameter, 180 mm long,
- 2 x 80 mm diameter end caps,
- 1 x plastic rain cover
- 1 x gutter bolt, to attach rain cover to end cap
- 1 x bracket
- 2 x gutter bolts to attach bracket to end cap
- 2 x mounting screws
- 1 x grub screw (threw bottom end cap, to ensure correct orientation of tube)

All items are available from Bunnings, Whakatāne except the rain covers which are plastic camping plates from the Warehouse. The Marley PVC tube is available in 3 metres lengths, 9 metres is required. 46 tubes are required, 46 end caps are required (approximately \$523). 23 brackets are required along with 69 ¼" gutter bolts. 46 mounting screws and 23 smaller grub screws. 23 rain covers from The Warehouse.

Tube labelling – each sampling site will have two designated tubes which will be labelled with a site unique numerical ID number and a unique alpha ID. For example monitoring site 1 will have two tubes, one labelled 1A and one 1B. Site 2 will be labelled 2A and 2B and so on.

Each tube will also have a Bay of Plenty Regional Council sticker placed on the lower section of the tube (see Figure 1).



Figure 1 Example of direction dust sampler

2 Sampler setup

2.1 Selection of monitoring sites

In the selection of a particular sampling site, it is essential that the sampling unit be situated so as to yield data which is representative of the location. It should not be unduly influenced by immediate surroundings unless those influences are specifically being monitored.

2.2 Site considerations

Based on operational experience and experimental data, a number of general guidelines (Standards Association of Australia, 1987) can be listed as follows:

- Avoid sites that have restricted airflow in the vicinity of the sampling inlet, such as sites adjacent to buildings, trees, walls, etc. As a general rule a sampling inlet should be located away from any nearby structure to the extent that the sampling inlet has a maximum clear sky angle of 120° (see Figures 2 and 3). This rule is not always applicable e.g. peak station measuring carbon monoxide in a street canyon.
- Avoid sites where physical interference may produce atypical results e.g. measuring particulate matter near domestic or commercial incinerators, electrical interference to sampling equipment from nearby high voltage lines.
 - Seek sites which are secure and have a low potential for vandalism.
 - Seek sites that have convenient access.

- Ground level sampling sites are appropriate in low or sparsely built up areas. Rooftop sampling sites are acceptable for a number of purposes in moderate to high density areas (in terms of structures).
- Rooftop sampling sites should be clean and should not be affected by flue emissions or other local sources of pollutants.
- Local activities around a sampling site may change its suitability as a site, either temporarily or permanently, e.g. demolition or construction activities, re-routing of motor vehicle traffic.

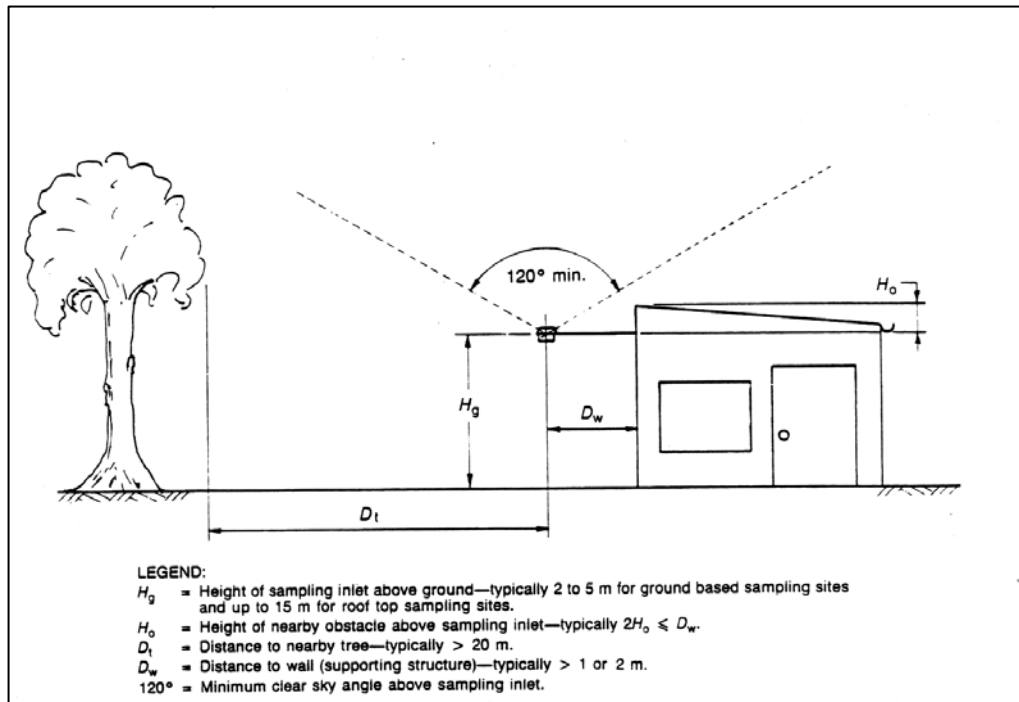

Figure 2 Generalised ground level sampling site

2.3 Pollutant and source considerations

Variations in pollutant levels in ambient air depend on the spatial distribution of their sources – an anthropogenic activity in most cases. These emissions and their subsequent dispersion under the influence of meteorology, climatology and topography, determine how sampling units for specific pollutants should be sited.

Suspended fine particulate matter is usually well mixed within the first hundred metres of air above the ground. Unless the sampling site is close to an emission source, e.g. stack, both ground level and roof top sampling sites are acceptable. Entrainment of surface particulate matter can occur with ground level sites unless the ground surface is free from dust, e.g. a grass cover area is usually satisfactory for overcoming this problem.

2.4 Position of the sampling film

When monitoring is performed for reasons associated with dust nuisance, the sampling point should be near the visible soiling zone, i.e. around one to three metres above ground level. Practical considerations, such as the prevention of vandalism, security, accessibility, require that the sampling inlet be elevated. Consequently, a range of heights for the sampling film is usually specified, representing a compromise between a desired sampling height and practical matters. For many pollutants, a sampling film height of two to five metres is acceptable for ground level sampling sites.

In many cases the sitting of a sampling unit needs to be related to the meteorological conditions, e.g. there should be no impediment to air approaching the sampling inlet particularly in the predominant wind direction.

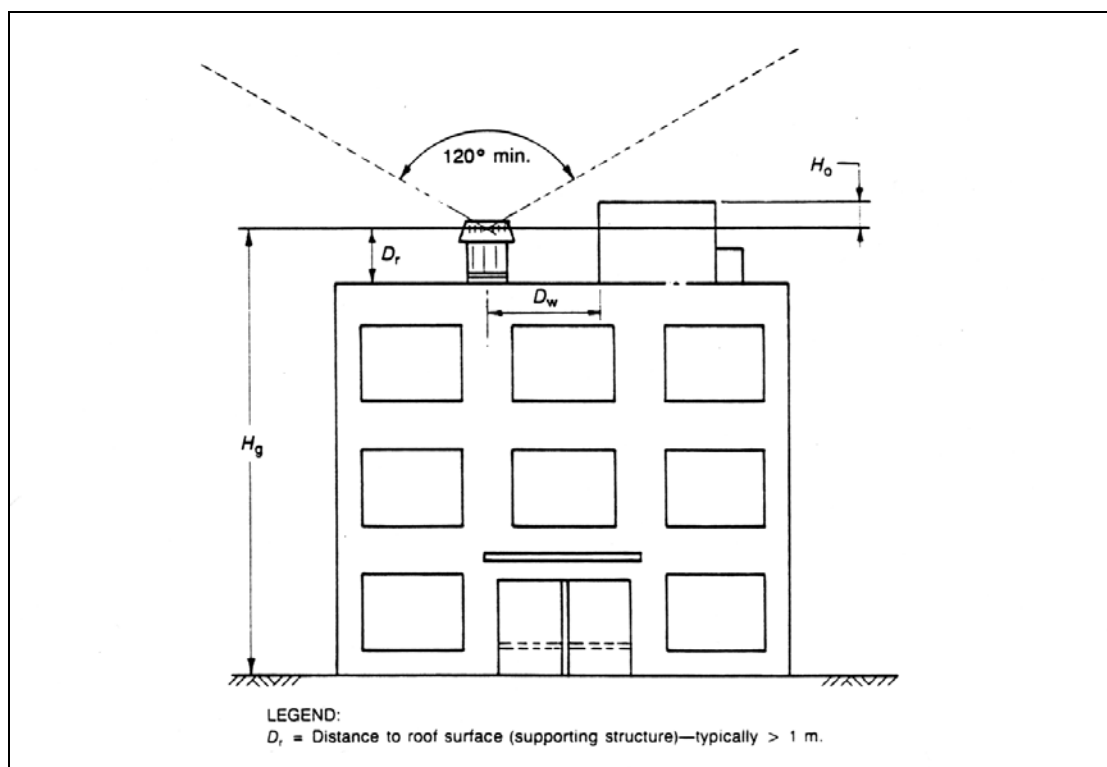

Figure 3 Generalised rooftop sampling site

2.5 Proposed Monitoring Sites

Figure 4 shows the general layout of the proposed sampling network for the Mount Maunganui area. The locations shown in this figure are not an indication of exact locations but rather to be used as a guide for the general layout of the 23 samplers.



Figure 4 Indicative sampling locations (23)

3 Sample deployment/collection

3.1 Sampler preparation

The adhesive film used for sampling has been field tested and under typical conditions will collect material for approximately 1-2 weeks.

For the 80 mm diameter sampler tube, a strip of adhesive film 250 mm in length is to be attached to the circumference of the tube. The film is held securely in place by double sided tape at each end of the strip of film. This film is mounted 30 mm from the top of the sampler, this allows enough space for the endcap and rain cover to be fitted. The point where the two ends of the film come together should be aligned with the north line (grub screw position).

3.2 Sampler orientation

Each sampler base has a numerical UniqueID, each sample tube has a numerical UniqueID these ID's should always match as each sampler has been orientated in relation to grid north.

A grub screw (and north line) has been placed in the sampler base which should always be installed and will confirm correct orientation of the sampling tube.

3.3 Sampler exposure

The sampler should always be orientated with the north line and grub screw pointing to grid north.

3.4 Sampler collection

Following the exposure period of a maximum of 10 days the tubes can be collected and replaced with new tubes. Care should be taken to avoid contamination of the film during pre and post exposure. The transporting boxes should be used to minimise any contamination.

The field log book should be filled in stating the site number/film number (sequential), exposure dates/time and any other relevant comments such as damage, suspected tampering etc.

3.5 Sample preparation

Back in the office/lab the adhesive film should be carefully removed, avoiding any creasing or twisting. Each length of film should then be placed sticky side down in a landscape fashion on an A4 sheet of heat binding cover film (supplies in the photocopying room) and labelled with the site number, film number and exposure start and end dates, and the word "Top" indicating the edge which was closest to the rain cover.

Each of these sheets should then be placed in the appropriate section of the Mount Maunganui Sample Register folder.

With the sample film now placed on the heat cover film, scanning of the sample can now be undertaken. In each scan ensure that the word "Top" is included in the scan. The settings for the scan should be as follows:

- Grayscale
- 1200 dpi
- Jpeg output

Each scan should be saved with the following filename format:

- <site number film number start date>.jpg, e.g. 1 15 2008-07-23.jpg

Finally this information should then be updated in the Mount Maunganui Sample Register spreadsheet (R:\USER\Shane\Air\Compliance\Mount Maunganui Dust\Mount Maunganui Sample Register.xls).

4 Particle analysis

4.1 Preparation

Each scanned sample film (Figure 5) then gets subdivided into eight wind bins based on the following quadrants.

Name (Direction bin)	Degrees	Distance on film (mm) (from left hand end of film)
N	337.5 – 22.5	0 – 16.1 plus 241.9-258
NW	292.5 – 337.5	16.1-48.4
W	247.5 – 292.5	48.4-80.6
SW	202.5 – 247.5	80.6-112.9
S	157.5 – 202.5	112.9-145.1
SE	112.5 – 157.5	145.1-177.4
E	67.5 -112.5	177.4-209.6
NE	22.5 – 67.5	209.6-241.9

Open the image in Photoshop. Turn on the Ruler function in the View menu. Rotate the image so the text “Top” is at the top. Turn on the grid function and ensure the image is level. If not then use the *Rotate>Custom* tool in the *Image* menu to rectify.

Use the crop tool to trim the excess from the image. Set the Aspect Ratio to Custom, and the following dimensions and quality, width = 250 mm, height = 37 mm and resolution to 1200 pixels/inch.

To extract an image representing each direction bin (Table 1), use the crop tool with the Aspect Ratio set to Custom and the following dimensions, Width = 31.3mm and Height = 37 mm. Move the selection to represent the distances outlined in Table 1, using the ruler as a guide.

Once the section representing the direction bin has been cropped then SaveAs the image as a .jpg with the following file name format <direction bin site number film number start date>.jpg, e.g. NW 1 15 2008-07-23.jpg. The format should be set to maximum quality.

To select the next bin press the undo button which should return you to the image of the full film. And then repeat the process outlined above for each bin.

For the N (North) bin the two end sections need to be joined. First open a new file with the following characteristics: width = 31.3 mm, height = 37 mm, resolution 1200 pixel/inch, colour mode grayscale. Select the original image and set the Crop tool width to 15.65 mm and height 37 mm. Select the left hand end section as outlined for N in Table 1, crop, select the rectangular marquee tool and select. Then copy and paste this section into the new file. Return to the original image and select undo to see the entire film. Repeat this process for the right hand end. Then save the new file as N.

Once this is finished you should have saved eight individual .jpg files representing each of the direction bins in Table 1.

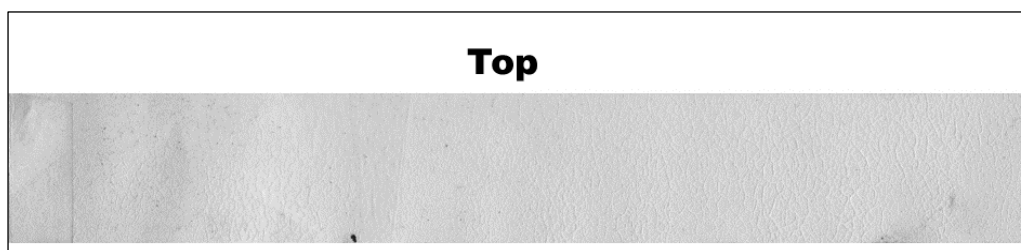

Figure 5 Example of scanned film

4.2 Processing

This component requires the ImageJ software to be installed on your machine.

If not installed the ImageJ software can be found at <\\Jupiter\Software\Installs\Working\NonReplicated\GIS\ImageJ> or <http://rsbweb.nih.gov/ij/>.

- Open the Mount Maunganui Sample Register spreadsheet
- Open ImageJ software
- Open direction bin image twice

- Position images so you can see both clearly, particularly focussing on a noticeable particle.
- Click on one image

Image>Adjust>Threshold. A histogram will appear. Adjust the bottom slider (normally between 140 and 150 is suitable) and compare with original image as parts of the image get highlighted or lost.

When a suitable image representing just the particles is obtained select *Apply*.

Analyze>Measure this will open the results dialog box.

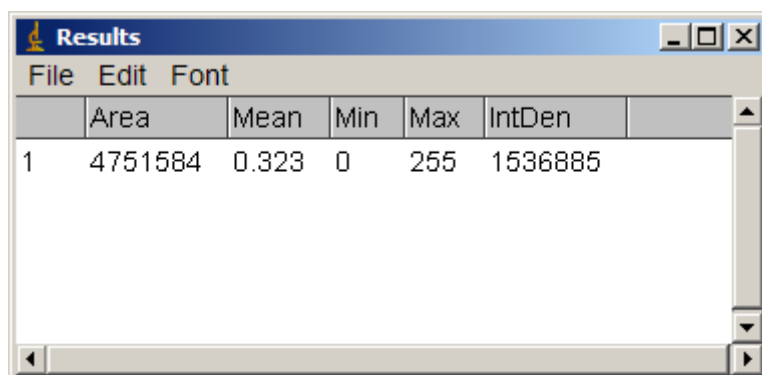

	Area	Mean	Min	Max	IntDen
1	4751584	0.323	0	255	1536885

Record the value shown in the Area column. This is the size of the entire image in pixels².

Analyze>Analyze particles (the settings should be as follows):

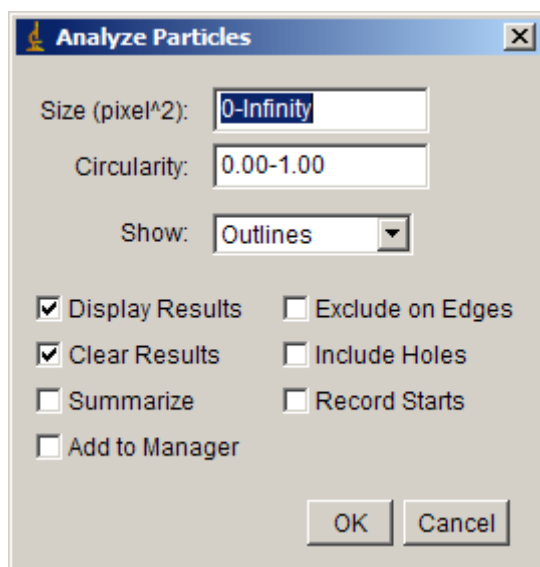

Size (pixel²): 0-Infinity

Circularity: 0.00-1.00

Show: Outlines

Display Results Exclude on Edges

Clear Results Include Holes

Summarize Record Starts

Add to Manager

OK Cancel

Click Ok

When prompted with the following dialog box chose No.

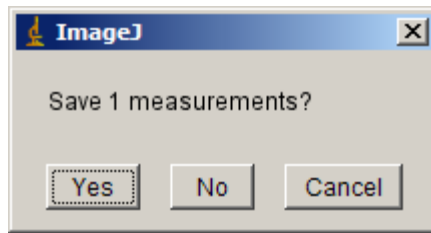

The results dialog box will be refreshed with the statistics of all the particles in the sector image (in this case 817 particles). Each of their area is listed.

A dialog box titled "Results" with a menu bar containing "File", "Edit", and "Font". Below the menu bar is a table with the following data:

	Area	Mean	Min	Max	IntDen
814	1	255	255	255	255
815	1	255	255	255	255
816	14	255	255	255	3570
817	4	255	255	255	1020

File>SaveAs. Type in the sector image name and the .xls extension, so that the results can be opened in Excel.

Open the file in Excel. Sum Column B and divide by the total image area calculated earlier. Multiply by 100 to convert to a percentage. Update the Mount Maunganui Sample Register spreadsheet with this percentage value.

When the *Analyze Particles* is undertaken a new image is produced with each particle identified and it Uniqued. This image is called Drawing of <filename>.jpg. Click on this image then *File>SaveAs* choose jpeg.

Appendix 5 – Directional Dust Detector Results

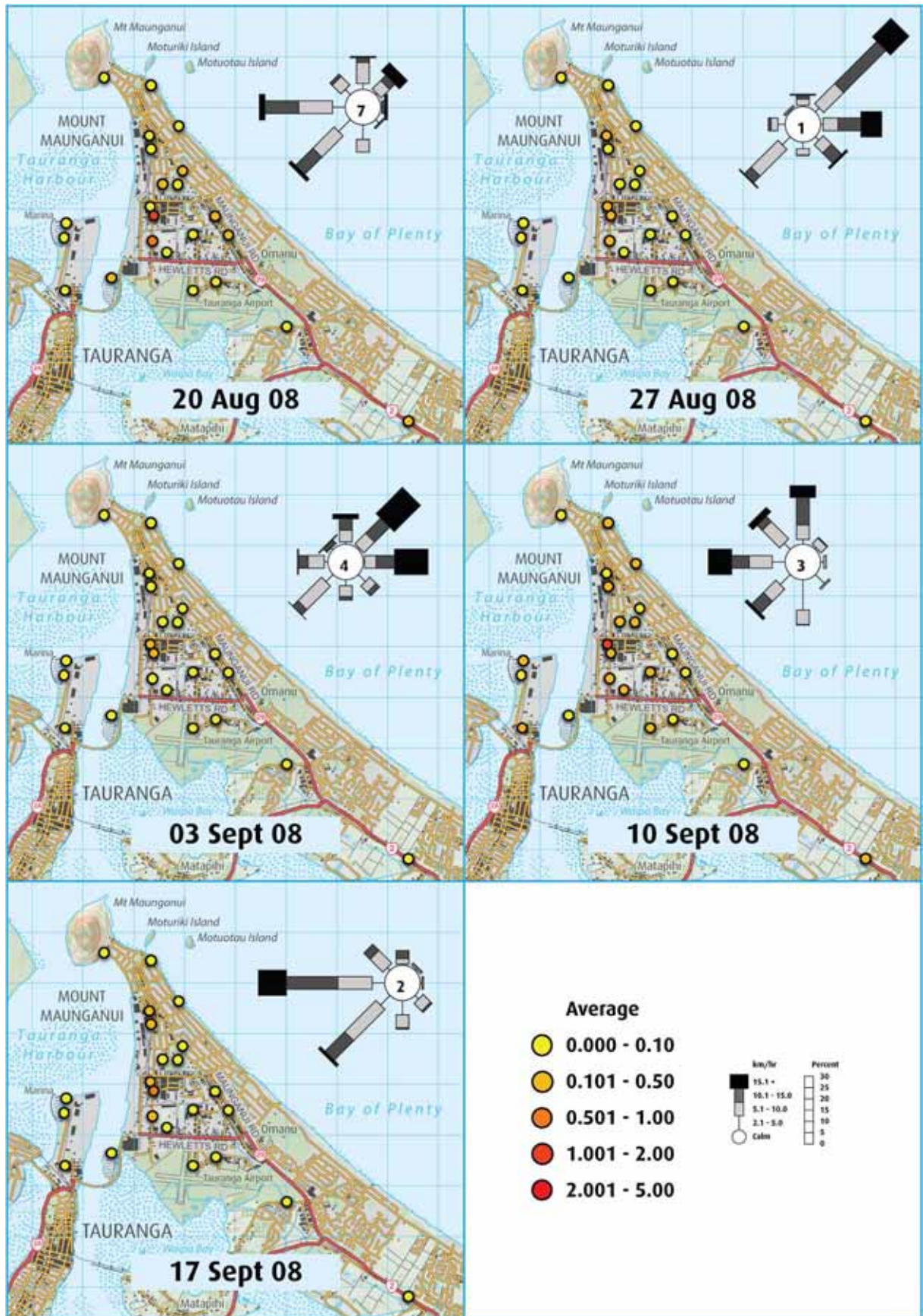

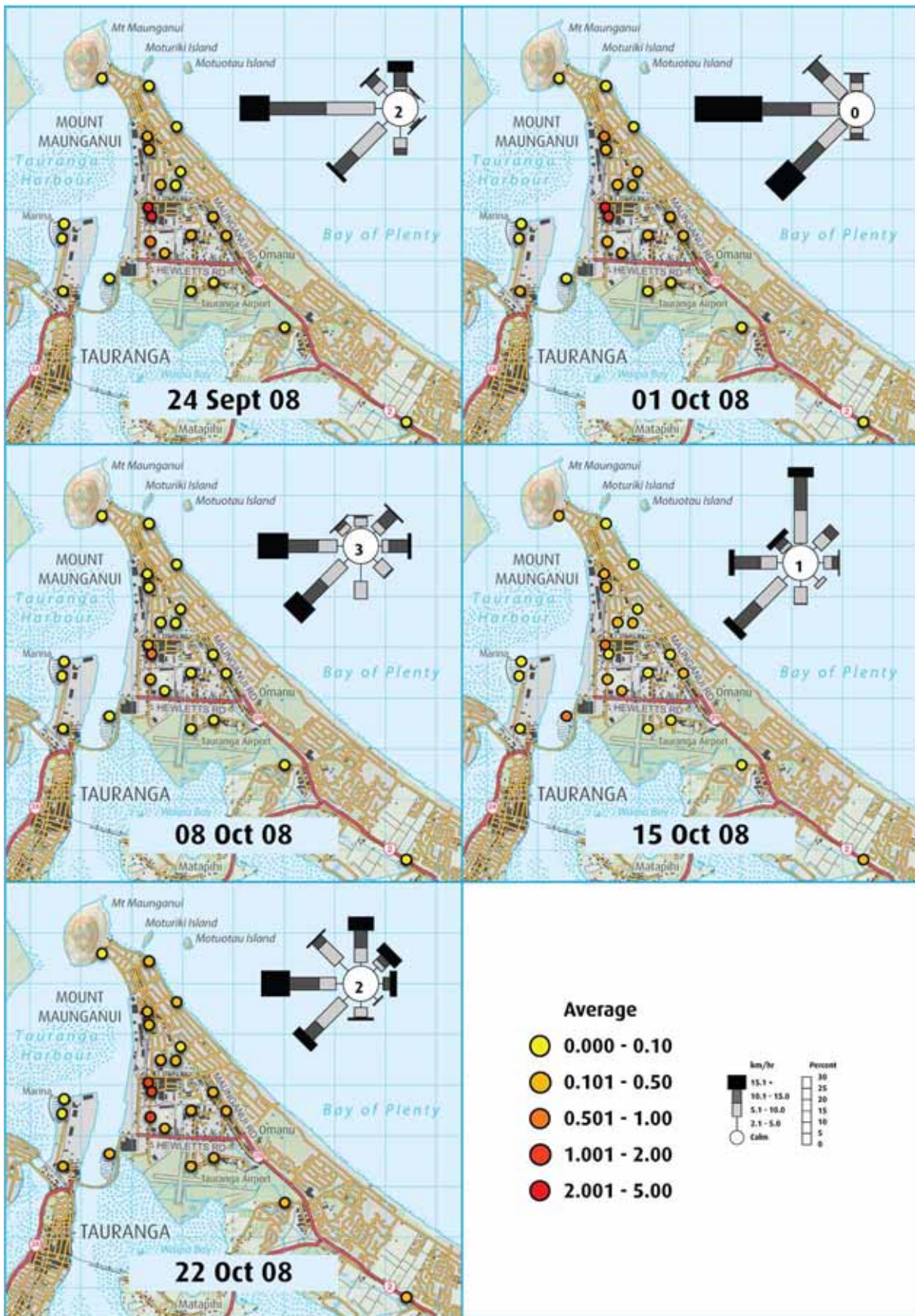

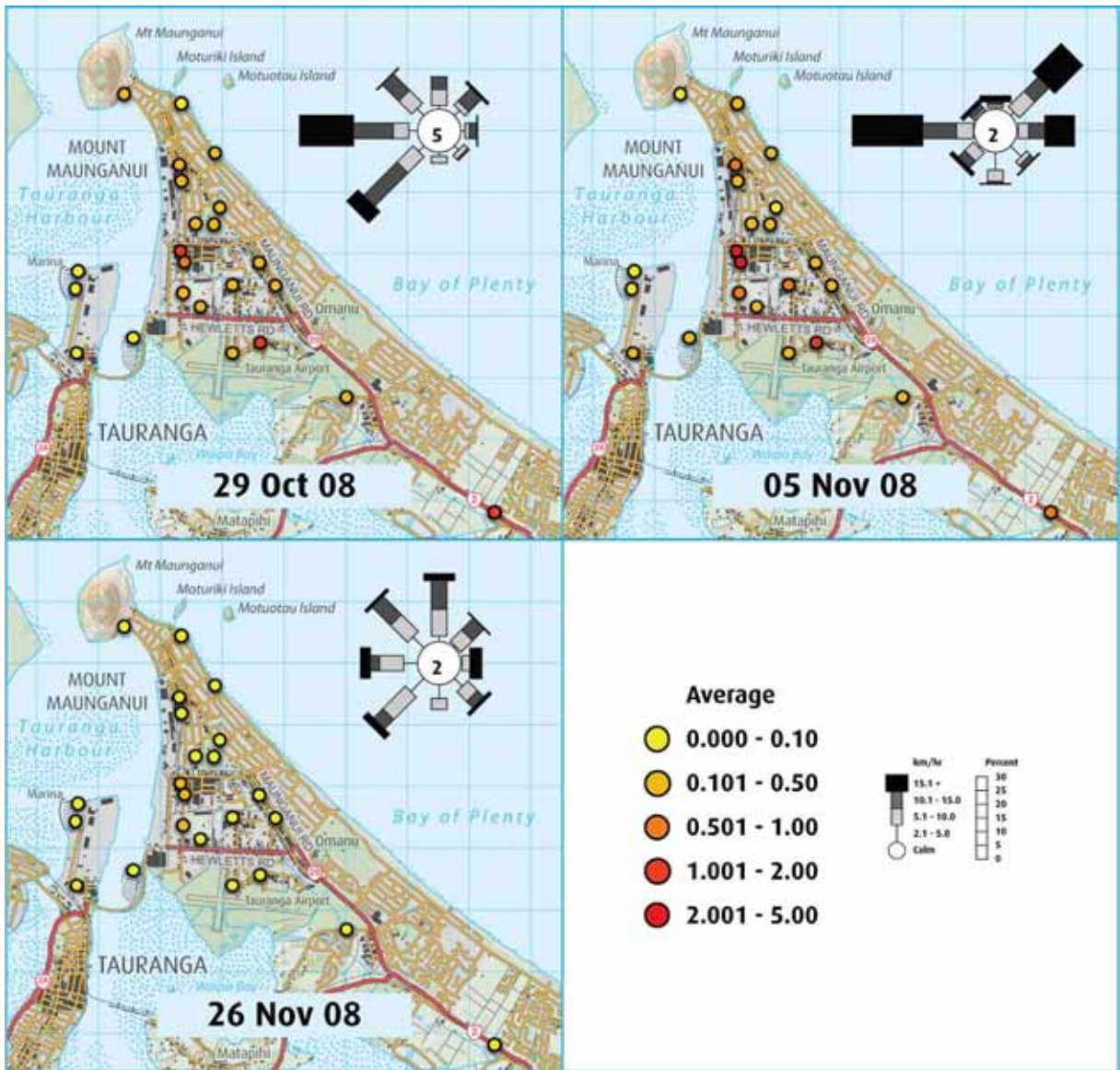

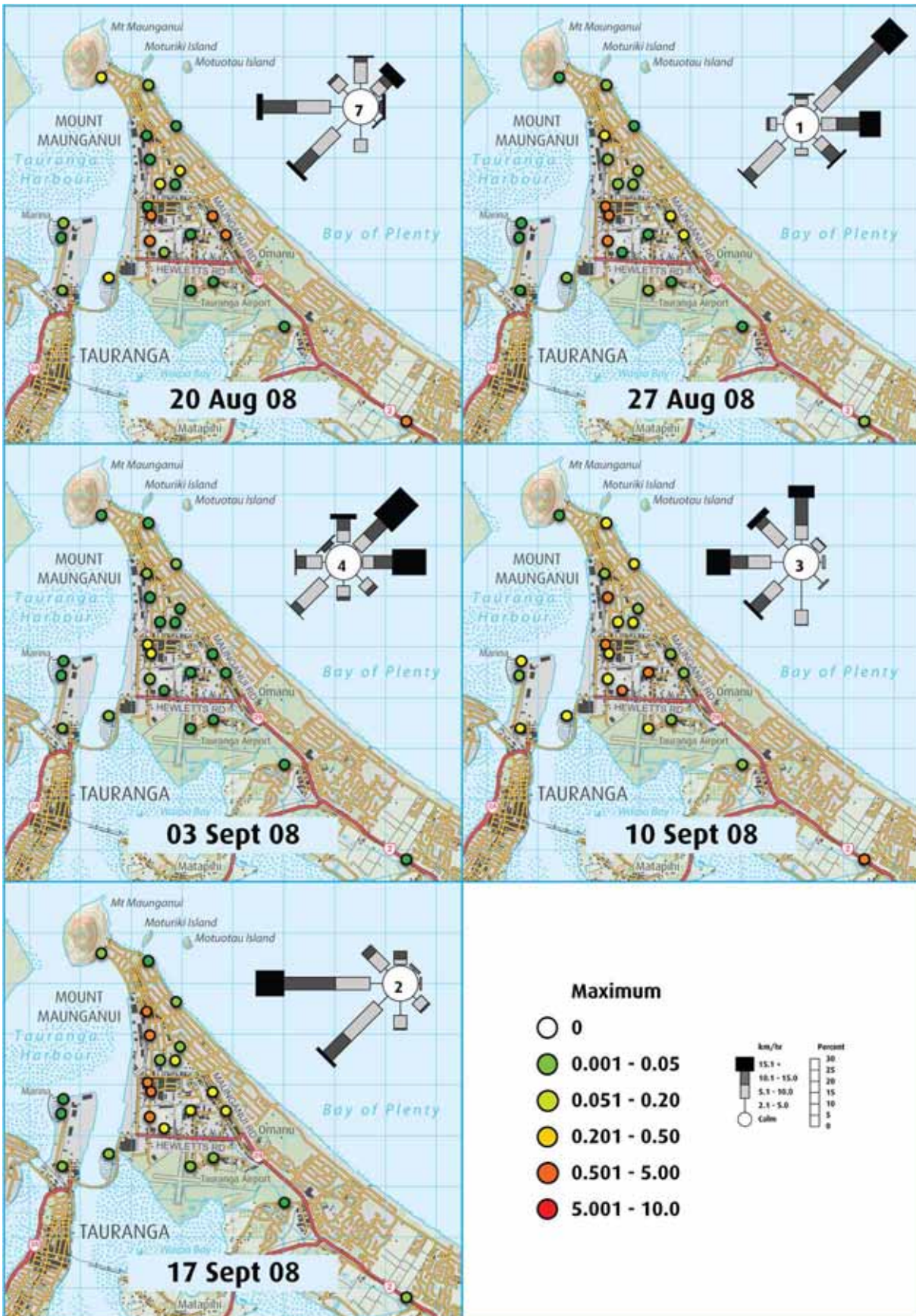

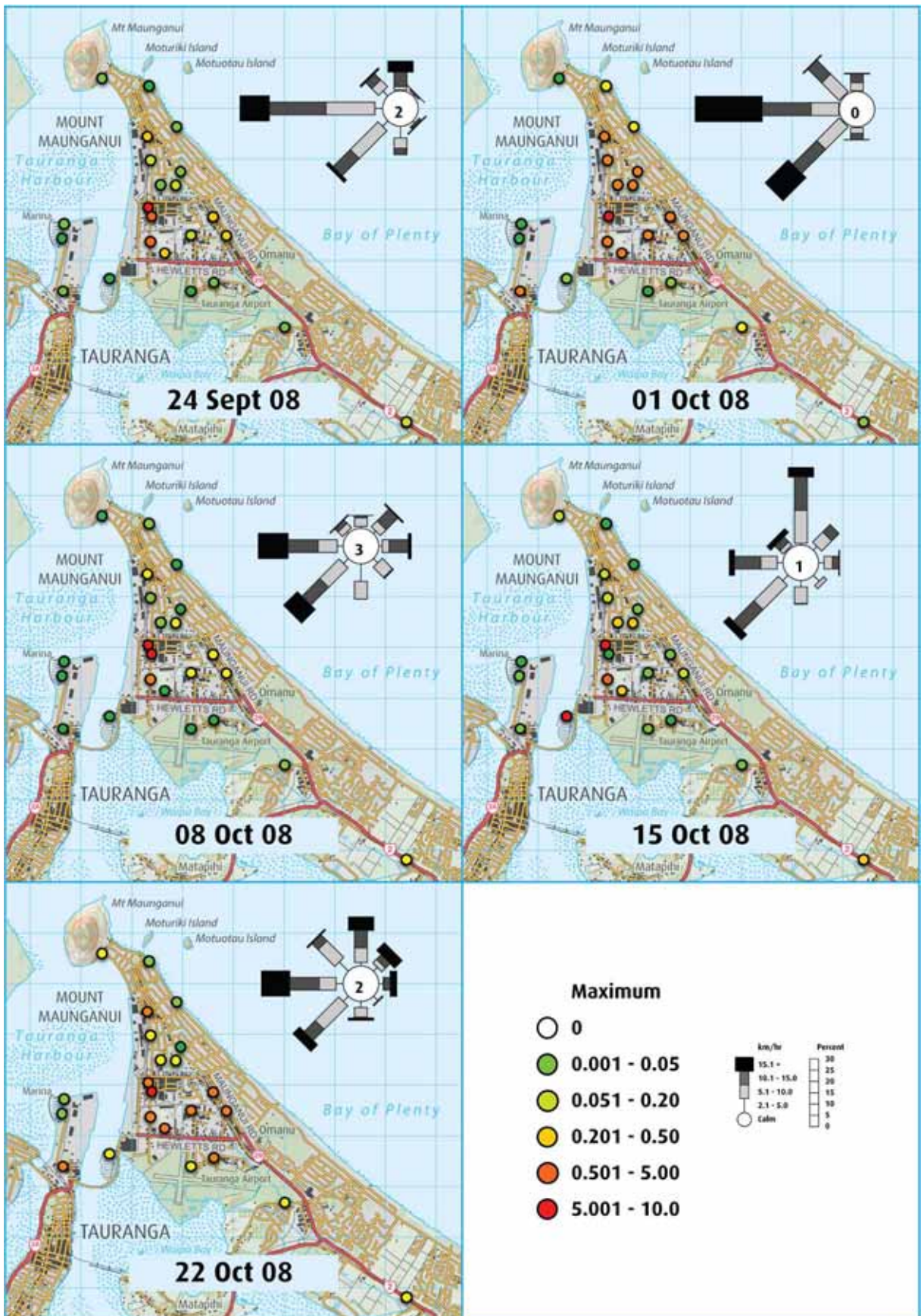

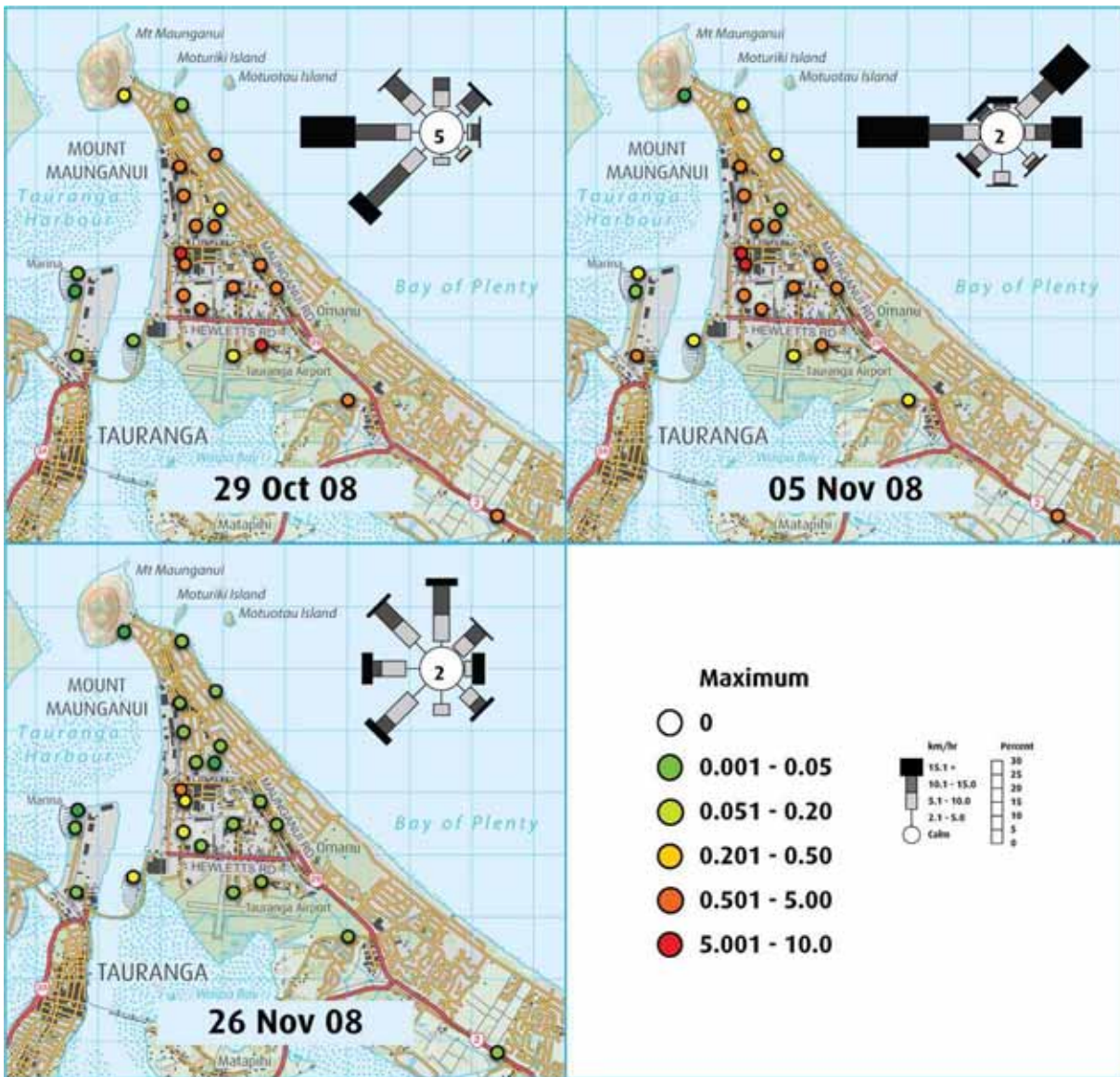

Appendix 6 – Independent particle assessment



2 Blumhardt Place
Avondale
P O Box 19-691
Avondale
Auckland 1746
New Zealand

13 September, 2011

Environment BOP
P O Box 364
Whakatāne 3158

Attention: Shane Iremonger

Assessment of Mount Manganui Dust Samples

As requested, I have examined the microscope images provided by you for the four dust samples collected from various locations around Mount Maunganui. My comments on the composition of each of the samples and the possible dust sources are given below.

Sample Details

The locations and collection dates for each of the samples were as follows:

Sample 1, collected 30 May 2008, from the deck of a boat moored at Tauranga Marina

Sample 2, no date provided, from the deck of a boat moored at Tauranga Marina

Sample 3, collected 3 February 2011, from a residential property in Miro Street

Sample 4, collected 23 May 2008, from the deck of a boat moored at Tauranga Marina.

Assessment Methodology

The following types of microscope images were examined:

Optical microscopy: the bulk samples are examined and photographed using an optical microscope, with a resolution of about 1 to 10 microns. This allows individual particles to be examined on the basis of their colour, shape and general physical appearance. It also allows an overall assessment of the mixture of particles, including checking whether the samples are dominated by one or more types of particles, which could possibly indicate a specific source.

Electron microscopy: this allows individual particles to be examined under much higher resolution than the optical microscope – typically down to 0.1 to 1 micron. Once again, the particles are examined on the basis of their shape and general physical appearance. However, the microscope is also fitted with an energy-dispersive attachment which gives a measurement of the elemental composition of the particles.

The identification of individual particles and the overall assessments of each sample are based on a combination of comparisons against published images for known materials and, most importantly, the experience gained from the examination of samples collected from a wide range of sources.

Assessment of the Samples Using Optical Microscopy

The optical images for all four samples showed them to be mixture of general urban dust. None of the samples was dominated by any specific types of particles.

Assessment of the Samples Using Electron Microscopy

All four samples included most or all of the following types of particles:

Sand minerals – characterised by a white or off-white crystalline chunky appearance, and relatively high proportions of silicon and oxygen.

Soil minerals – similar to sand particles but off-white or brown, less crystalline in appearance, and often made up of an agglomeration of smaller particles. Significant proportions of silicon, oxygen, aluminium and magnesium.

Calcium carbonate (limestone) – chunky agglomerated appearance with high proportions of calcium, carbon and oxygen.

Road wear particles – agglomerations of irregular shaped particles, usually brown, black or grey, and containing seemingly random mixtures of metals, including iron, titanium, chromium and zinc. The presence of significant amounts of titanium is most likely due to its use in paints.

Metal wear particles – similar in appearance to road wear particles but including a wider range of colours (eg. yellow, orange) and higher proportions of individual metals.

Tyre wear particles – elongated dark grey or black particles with a rolled, crumbly appearance, characterised by relatively high proportions of carbon, oxygen, silicon, calcium and iron.

Cenospheres – spherical particles, often hollow and with a honey-comb appearance in the outer shell. They have high proportions of carbon (typically 60 - 80%) and varying, but significant, amounts of sulphur (ca. 2 – 6%) and a range of trace metals. These particles are formed as products of incomplete combustion of fuel oil.

Salt particles – these are usually associated with other materials rather than as discrete particles, and are characterised by the presence of significant amounts of sodium and chlorine.

Pollen – most pollens have characteristic shapes that make them readily identifiable under the microscope.

Plant and insect debris – again these are usually easily identifiable by their appearance under the microscope, and the predominance of carbon and oxygen in the elemental mix.

The above mixtures of particles are typical of general urban dust. No individual types of particles were especially dominant in any of the samples, which indicates the lack of any major contribution from a specific source or sources.

Yours sincerely



Bruce Graham
Consultant

Appendix 7 – Industry stack sample analysis

**GRAHAM
ENVIRONMENTAL
CONSULTING LTD**

30-44 Esplanade Rd
Mt Eden
P O Box 19-691
Avondale
Auckland 1746
New Zealand

27 January, 2012

Bay of Plenty Regional Council
P O Box 364
Whakatāne 3158

Attention: Shane Iremonger

Assessment of Stack Particulate Samples from Mount Maunganui Sources

As requested, I have examined the electron microscope results provided by you for the filter samples collected during stack testing of a number of industrial sources in Mount Maunganui. The comments below provide a summary of the types of emissions expected from each of the sources and my observations on each of the samples. I have also included comments on two other sources that were not tested.

This work was intended to complement the earlier analysis of deposited dust samples, which was reported in September 2011. A copy of my report on those samples is attached.

Stack Sample Details

The samples were collected by a stack testing team from Air Resource Management Limited who were contracted by the Regional Council to carry out emission audits on each of the following industrial sources:

- Allied Asphalts (asphalt plant)
- Higgins Contractors (asphalt plant)
- NZ Marine Services Ltd (waste oil processor)
- Ballance Agri-Nutrients (acid plant and fertiliser manufacturing plant)
- Lawter (NZ) Ltd (specialty chemicals plant)
- Momentive Specialty Chemicals (NZ) Ltd (resins and adhesives manufacturer)

The stack tests were carried out during October and November 2011, and the audit results have already been reported to the Regional Council. The filter samples required for the current work were collected at the same time as the audit tests and were analysed by you on 19 January 2012. I understand the delay in analysis was primarily due to difficulties in obtaining access to the electron microscope facility at the University of Waikato, but should not have had any adverse effects on the samples, which were stored in sealed plastic bags.

Assessment Methodology

The samples were analysed using electron microscopy, which allows individual particles to be examined at a resolution of 0.1 to 1 micron, with the results captured on photographs. The particles are examined on the basis of their shape and general physical appearance. In addition, the microscope is fitted with an energy-dispersive attachment which gives a measurement of the elemental composition of the particles.

Actual and Potential Emissions from Each of the Sources

The potential emissions from each of the sources are summarised below, along with comments on the actual samples taken for analysis.

Allied Asphalts

The primary emission from asphalts plants is aggregate dust which can be released from the rotary drier. This material would have a grey colour and could be moderately abrasive. On most New Zealand plants the drier exhaust gases are passed through a water scrubber, which should remove 90% or more of the emissions prior to discharge. There is also the potential for smoke emissions from fuel combustion, if the burner is not properly adjusted.

The audit test on the Allied Asphalt plant showed that the particulate emissions were less than a third of the consent limit. This was reflected in the filter sample for this site, which appeared to be completely free of any dust particles.

Higgins Contractors Ltd

The audit test on the Higgins asphalt plant gave a much higher result than Allied Asphalts, and was 1.8 times the mass emission limit specified in the air discharge consent. In this case, the electron microscope showed that the filter was caked with a layer of material with an appearance consistent with that of wet aggregate dust. No individual particles were discernible at a resolution of about 10 microns, which indicates that the material was very finely divided (ca. < 1 micron). The dominant elements were calcium, silicon and aluminium, which is as expected for an aggregate source (ie. calcium/aluminium silicates).

NZ Marine Services Ltd

NZ Marine Services Ltd processes waste oil for reuse as an industrial fuel. Some of the waste oil is burnt in a furnace that provides the heat needed for processing, and this is a potential source of sulphur dioxide emissions and smoke (fine particulate).

The filter sample from this stack had several different deposits: several pieces of striated flakes of semi-crystalline material, about 5 to 10 microns wide and up to 50 microns in length, an occasional spherical particle up to about 5 microns in size, and a number of flat circular spots with diameters of 1 to 2 microns. The flakes contained significant amounts of zinc and phosphorous, and can be attributed to deposits of zinc phosphate salts (eg. zinc dithiophosphates are used as anti-wear additives in oil). The spherical particles had the characteristic appearance and high-sulphur content of cenospheres, which are formed as by-products of oil combustion. And the circular spots, which lacked any depth or significant elemental patterns, are almost certainly the residues from evaporated water droplets.

Ballance Agri-Nutrients

The Ballance fertiliser plant uses sulphur to produce sulphuric acid, and then manufactures superphosphate by reacting phosphate rock with the sulphuric acid.

The grinding of the phosphate rock is a potential source of dust emissions. However, the grinding mills are fitted with bag filters with a collection efficiency of greater than 99.9%. This means that the actual dust emissions should be minimal, and no samples were taken from the bag filter exhausts. If any significant amounts of dust were released from these, it would be a non-abrasive powder with an off-white colour. The particles are expected to be less than 10 microns in size, and would be easily identifiable from their high phosphorous content.

The manufacturing plant (or 'Den') is another possible source of particulate emissions, but these are controlled by a scrubber. In this case the emissions would be a mixture of phosphate rock and superphosphate, and sulphuric acid droplets. The manufacturing plant is also a source of gaseous fluoride emissions, while the discharges from the sulphuric acid plant are primarily sulphur dioxide gas, and sulphuric acid mist.

The audit tests on the fertiliser plant covered emissions from the manufacturing plant and the acid plant, both of which are covered by consent conditions. The filter from the acid plant test was virtually free of any deposits, which is as expected. The filter from the manufacturing plant showed two types of deposits: a few opaque slug-like deposits, and numerous small (~0.5 – 1.5 micron), partly hollow, spherical particles. The 'slugs' had a high sulphur content, which is consistent with droplets of sulphuric acid. The spherical particles contained significant amounts of silicon but no phosphorous. These particles have a quite unique appearance under the microscope and they were not seen in any of the dust samples examined last year. They are most likely silica microspheres formed as a very minor by-product of the manufacturing process.

Lawter (NZ) Ltd

This company, formerly known as Hexion and, prior to that, Pine Chemicals Ltd, produces a range of specialty chemicals from turpentine and Tall Oil, which are obtained as by-products from the two North Island pulp and paper mills. The manufacturing process involves fractional distillation of the liquid raw materials and should not be a significant source of particulate emissions. However, there is some potential for smoke (fine particulate) emissions from the furnaces used for heating the distillation units.

The filter sample from this source showed a few semi-crystalline particles, 1 to 5 microns in size, and containing significant amounts of calcium, sodium, oxygen and sulphur. These are most likely deposits of calcium and sodium sulphate salts, which would have been formed as by-products of the combustion process.

Momentive Specialty Chemicals (NZ) Ltd

Momentive (formerly Orica) manufactures a range of resins and adhesives, which are produced from formaldehyde-based polymers. The primary contaminant in the plant emissions is formaldehyde gas, and there should be no significant particulate emissions. This was confirmed by the filter sample which appeared to be completely free of any particles.

Golden Bay Cement Ltd

The Golden Bay facility is a potential source of dust emissions from the handling and storage of cement. This plant was not tested, but the emissions would consist of an off-white or grey, mildly alkaline powder, and could be easily characterised under the electron microscope as mixtures of calcium silicates, sulphates, aluminates and alumino-ferrates. The particle size distribution of cement dust is typical quoted as 3 to 100 microns. However, if any fugitive emissions were to occur during handling they would tend to be concentrated towards the lower end of that range.

Port of Tauranga

The potential dust and particulate sources associated with the Port activities would include any or all of the following:

- Motor vehicle and ship emissions (smoke and other combustion particles, including cenospheres, and dust emissions from vehicle movements over dusty surfaces)

- Log storage and handling, and vehicle movements over the storage areas (bark and wood fibres, soil particles)

- Loading and unloading of potentially dusty materials (eg. fertiliser, coal and palm kernel)

- Wind-blown dust from sealed and unsealed surfaces.

The particles from some of these sources would be readily identifiable by the appearance under the microscope and/or chemical composition (eg. cenospheres, bark, coal dust, fertiliser). However, most others would be indistinguishable from general urban dust.

Overall Commentary

The stack samples have provided useful information on the types of particles that could be expected from some of the industrial sources in Mt Maunganui. Some of the particles are quite unique (eg. the semi-crystalline materials found at NZ Marine Services and Lawter (NZ) Ltd), and would be easily identified in samples of fallout. Other particles also have a unique appearance (eg. cenospheres) but can be produced by a number of different sources. However, there are also particles that would be difficult to distinguish from those commonly found in most urban environments (eg. cement dust, and aggregate dust from asphalt plants).

The main aim in collecting these samples was to support the earlier work on deposited dust samples, through possibly identifying particular causes of the dust fallout. However, it was noted in the earlier report (as attached to this report) that the particles found in the dust deposits were typical of general urban dust. And:

No individual types of particles were especially dominant in any of the samples, which indicates the lack of any major contribution from a specific source or sources.

The lack of any dominant particles in the deposition samples clearly indicates that there is no one single source causing these fallout problems. Rather, they are most likely the result of general accumulations of dust as a result of contributions from the numerous possible sources in the Mt Maunganui urban area. These sources would include natural releases of airborne matter (soil, vegetation and sea spray), domestic activities (cooking, heating, gardening and rubbish burning), commercial activities (cooking, heating, gardening and construction), transportation (cars, buses, trucks, trains and ships) and industry. These releases can occur on an almost continuous basis, but their impacts are likely to be more episodic in nature, due to variations in weather conditions, especially rainfall, and wind speed and direction.

Yours sincerely



Bruce Graham
Consultant